

BPW Original spare parts  
Series SH..; SK..; S..LL..  
with ECO Disc Trailer disc brakes

SH

SK

BPW ORIGINAL SPARE PARTS

S..LL

Contents		Page
	Explanation of BPW axle type codes	4
	Explanation of BPW axle code numbers	4
	BPW type plate	5
<b>1</b>	<b>Axle beams, steering axle beams</b>	<b>6 - 9</b>
1.1	Axle beams, steering axle beams, view	
1.2	Axle beams, steering axle beams, steering pivots, steering pivot bearing	8 / 9
<b>2</b>	<b>Steering rods, steering rod attachments, steering lock</b>	<b>10 - 15</b>
2.1	Steering axle, steering lock, view	10 / 11
2.2	Steering rods	12 / 13
2.3	Steering rod attachments, steering lock	14 / 15
<b>3</b>	<b>Brake parts BPW ECO Disc</b>	<b>16 - 33</b>
3.1	Brake parts BPW ECO Disc TSB 3709 / 4309 / 4312, view	16 - 19
3.2	Brake parts BPW ECO Disc TSB 3709 / 4309 / 4312	20 - 23
3.3	Brake discs, view	24
3.4	Brake discs	25
3.5	Disc protectors, brake pad slot protector	26 / 27
3.6	Brake cylinders, view	28 / 29
3.7	Brake cylinders	30 / 31
3.8	BPW Brake Monitor, view	32
3.9	BPW Brake Monitor	33
<b>4</b>	<b>Hub bearings, hub seals</b>	<b>34 - 43</b>
4.1	Hub bearings, hub seals, view	34 - 37
4.2	Hub bearing, ECO Plus 2	38
4.3	Hub bearing, ECOPlus	39
4.4	Hubs, ECO Plus 2, ECOPlus	40
4.5	Grease sprays for greasing taper roller bearings	41
4.6	Grease filling, bearing adjustment, ECO Plus 2	42
4.7	Grease filling, bearing adjustment, ECOPlus	43
<b>5</b>	<b>ABS</b>	<b>44 - 50</b>
5.1	ABS, view	44 / 45
5.2	ABS parts TSB 3709 / 4309 / 4312 - Rigid axles	46 / 47
5.3	ABS parts TSB 3709 / 4309 - Steering axles	48 / 49
5.4	ABS retrofit part sets	50
<b>6</b>	<b>Wheel studs</b>	<b>52 - 55</b>
6.1	Wheel studs, view	52 / 53
6.2	Wheel studs, single wheels / twin wheels	54 / 55
<b>7</b>	<b>Steering dampers</b>	<b>56 / 57</b>
7.1	Steering dampers, view	56
7.2	Steering dampers	57
<b>8</b>	<b>Hubcaps with integrated Hubodometer</b>	<b>58 / 59</b>
8.1	Hubcaps with integrated Hubodometer	58
8.2	Hubcaps with digital odometer (ECOMETER)	59
<b>9</b>	<b>Special tools for BPW ECO Disc Trailer disc brakes</b>	<b>60 - 63</b>

Valid: 1.9.2010

This spare parts list shows fast moving parts for BPW trailer axles and steering axles **series SH.. / SK.. 8 - 12 tonnes** from 2010 onwards.

Additional spare parts as per spare parts catalogue.

Subject to change (without notice).



Rigid axle

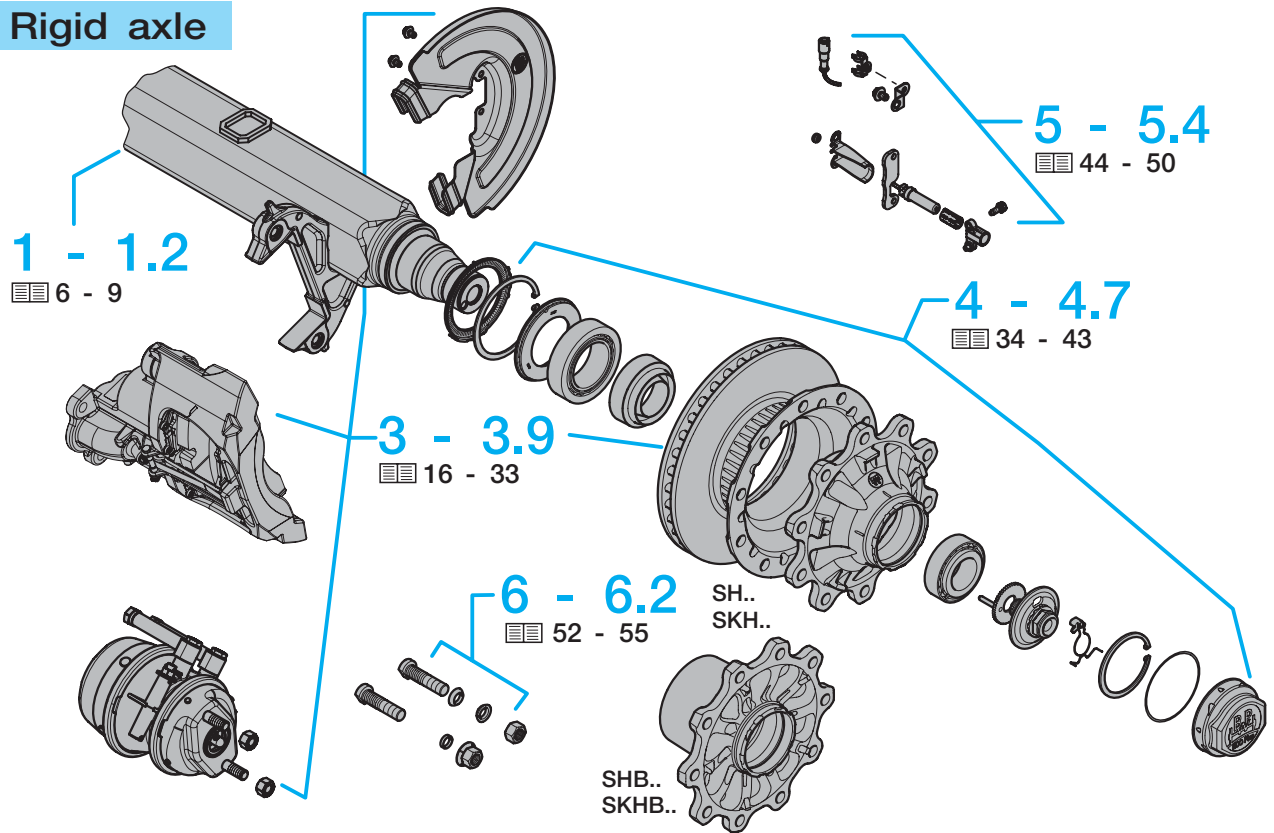

Steering axle

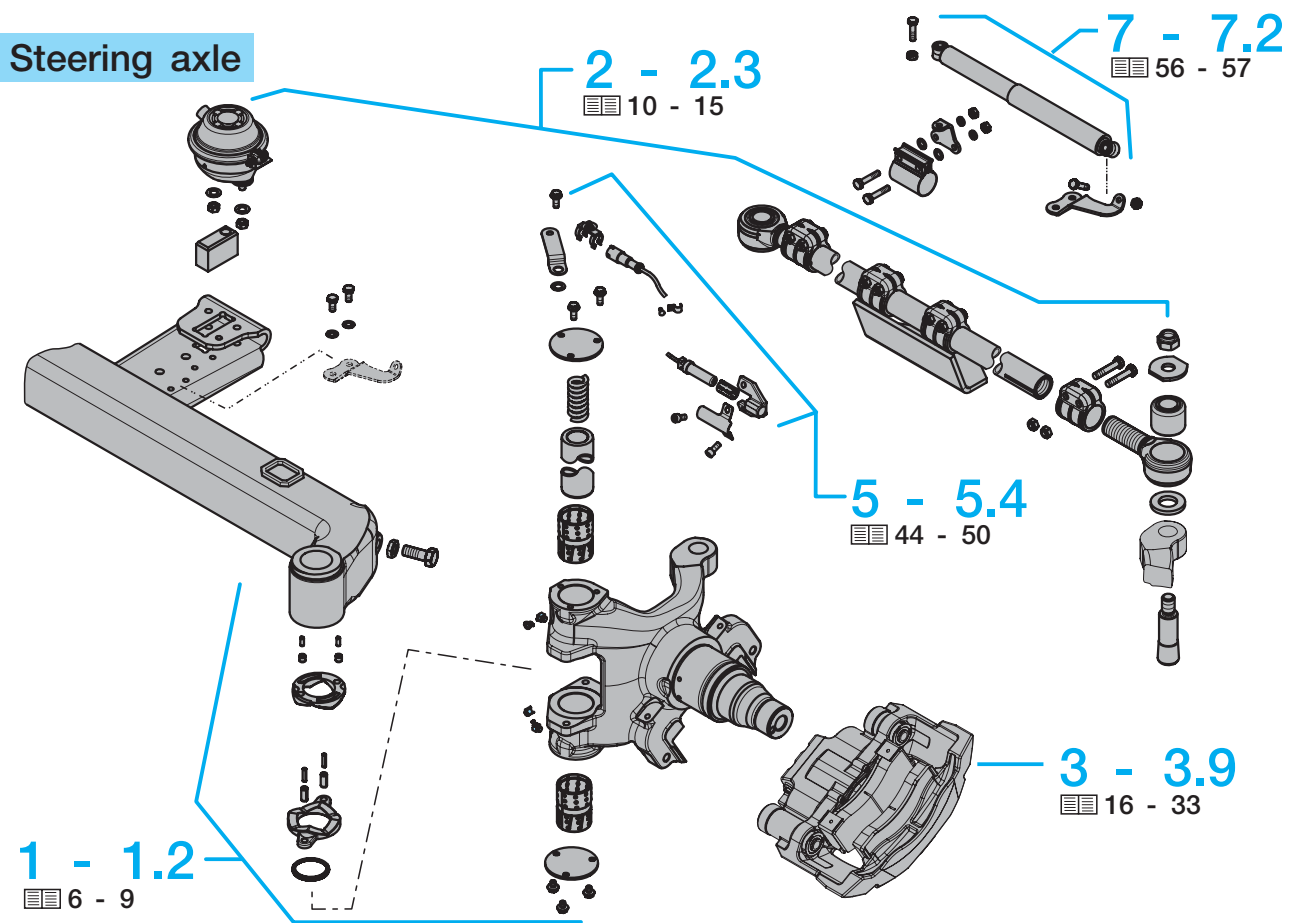

## Explanation of BPW axle type codes (extract)

Example:									
SKH	S	F	LL	9010	-15	ECO Plus 2			
							<b>Axle series</b>	<b>Brake</b>	<b>Tyre</b>
SH							SH..	TSB 4309	22.5" / 24"
							SH..	TSB 4312	22.5" / 24"
SKH							SKH..	TSB 3709	19.5" (22.5")
SM							SM..	TSB 4309	22.5" / 24"
								TSB 4312	
SKM							SKM..	TSB 3709	19.5" (22.5")
	B								For single wheels, wheels with offset
	S								For single wheels, wheels without offset
	Z								For twin wheels
		F							Wheel studs M 22 x 1.5 without wheel nuts, order wheel nuts for stud or spigot alignment separately
		M							For spigot alignment
			LL						Self steering axle, series LL
				8008 - 12010					Axle load (kg) + quantity of wheel studs per hub
					-15				Axle beam - wall thickness, e.g. 15 mm
					8°				Steering angle of steering axle
					- 27°				
						ECOPlus			Trailer axle with ECOPlus Unit
						ECO Plus 2			Trailer axle with ECO Plus 2 Unit

## Explanation of BPW axle code numbers (extract)

Example:						
27.	58.	616.	000			
				<b>Axle type</b>		
26.				Steering axle without suspension parts		
27.				Trailer axle without suspension parts		
				<b>Axle load</b>	<b>Roller bearings</b>	<b>Bearing generation</b>
	50.			10000 - 12000 kg	33118 / 33213	ECOPlus
	58.			8000 - 9000 kg	33118 / 33213	ECO Plus 2
				<b>Wheel brake type</b>	<b>Dimension</b>	
		616.		TSB 3709 (ECO Disc)	Ø 370 x 45	
		617.		TSB 4309 (ECO Disc)	Ø 430 x 45	
		618.		TSB 4312 (ECO Disc)	Ø 430 x 45	
			000	Consecutive number 000 - 999		

## BPW Type plate

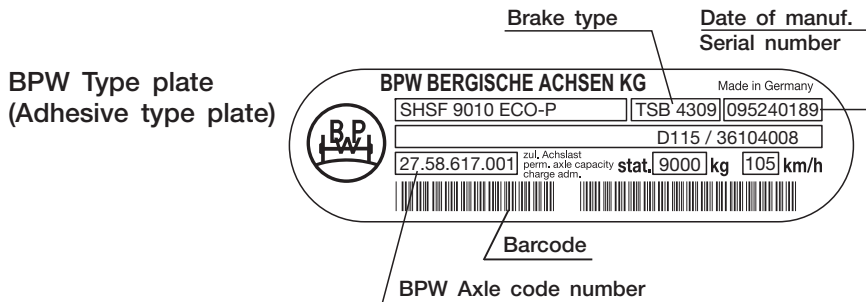

	Example:
The BPW type name is composed of a letter group and a number group.	SHSF 9010 ECO-P
The letter group identifies the type of axle and suspension version as well as defining the hub version.	SHSF - BPW axle series SH for single wheels (without offset), wheel studs M 22 x 1.5, without wheel nuts
The number group specifies the axle load on the ground in kilogrammes and the number of wheel studs per wheel hub (for disc wheel connection).	9010 - 9000 kg axle load - 10 wheel studs per wheel
The group of letters at the end of the model name defines the type of hub bearing.	ECO-P - ECO <sup>Plus</sup> bearing generation
You can view the brake certificate referenced by certificate type/test report number on the type plate by logging onto the BPW website at <a href="http://www.bpw.de">www.bpw.de</a> (Download Centre in the German version of the website - "Bremsgutachten").	D115 / 36104008 - D115 Certificate type - 36104008 Test report no.

All BPW components and assemblies have a 10-digit "speaking" code number.

## 1.1 Axle beam, steering axle beam

View

### General

#### BPW Axle beams

Square, reliable, light – the BPW axle beam. It's the stable foundation for a long vehicle life. In combination with our brakes and suspension systems, the square axle produces axle systems which offer convincing all round performance with long service life and maintenance intervals.

The BPW square axle beam consists of two high-quality, specially rolled "U" sections which are welded together inside and out.

This profile features more material at the corner radii and less material in the top and bottom areas. As a result, the axle cross-sections are reinforced at the points where the force is applied and are optimally shaped to cope with the load.

The construction ensures a long service life.

BPW axle tubes are available with various cross-sections and wall thickness values depending on the axle load and the application conditions.

BPW axle stubs are forged, quenched and tempered.

They have two stepped bearing seats.

The axle stubs and axle tube are flash butt-welded together to produce the one piece BPW axle beam.

In this welding process, the axle tube and the ends of the axle stubs are heated up to welding temperature by an electric current applied at their joining faces, whilst at the same time being forced together.

This produces an absolutely homogeneous connection without any inclusions. In contrast to conventional welding processes, no filler metals are needed.

At the same time, the axle beam is given its camber and toe-in.

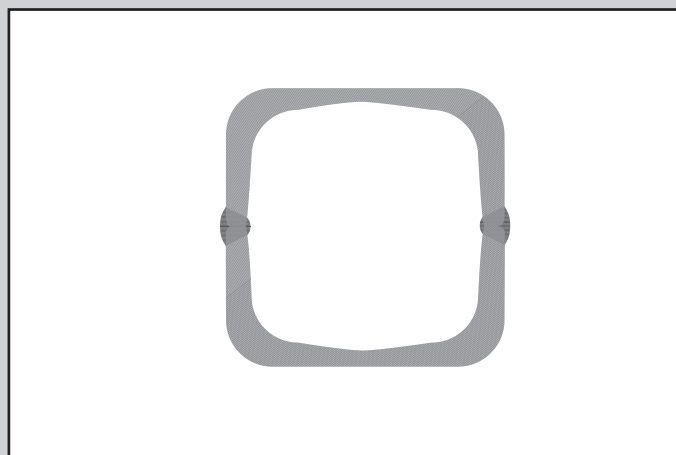
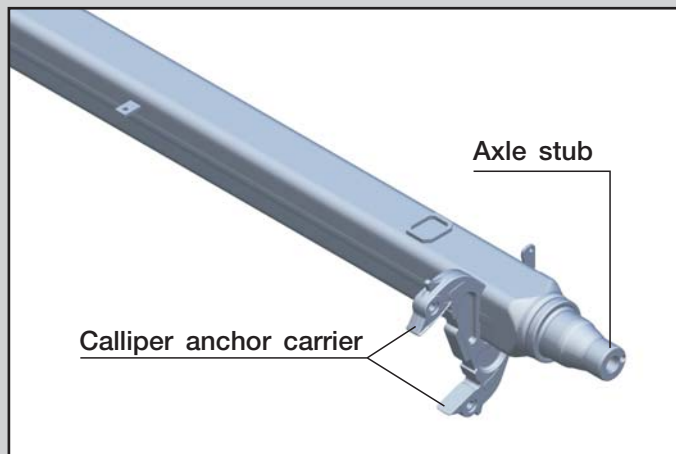

### Determining replacement axle beams

The BPW axle code number is shown on the type plate.

If this is missing or no longer legible, the BPW axle code number can be read off the front end of the axle stub in most cases.

When ordering the axle beam, quote this BPW axle code number with the reference to a replacement axle beam.

In steering axles and ECO Plus 2 bearings, there is no code number embossed on the front end of the stub.

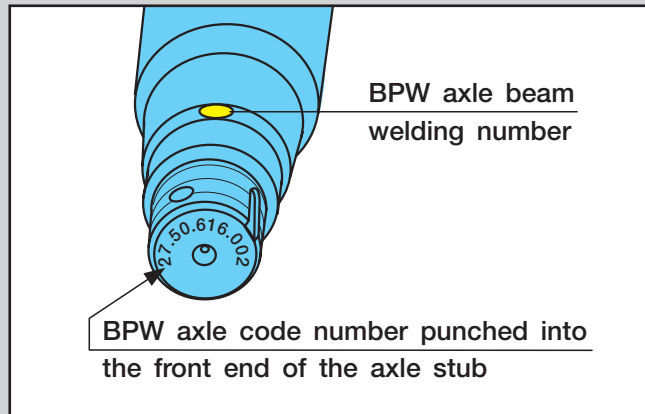

If there is no BPW axle code number or none is known, BPW can identify the axle on the basis of the axle beam welding number or the dimensions.

1. Axle beam cross section ( □ 120 / 150 )
2. Axle beam wall thickness ( if known )
3. Spring centre ( FM )
4. Track ( SP )
5. Overall width ( P )
6. Leaf spring width
7. Spring pad hole pattern ( if present )
8. Wheel seat ( H )
9. Pitch circle and number of wheel studs ( K )
10. With steering axles steering pivot centre

In addition to which the **type of tyres**, the **wheel size** and the **brake size** should also be specified, as well as the approximate year of manufacture (initial registration).

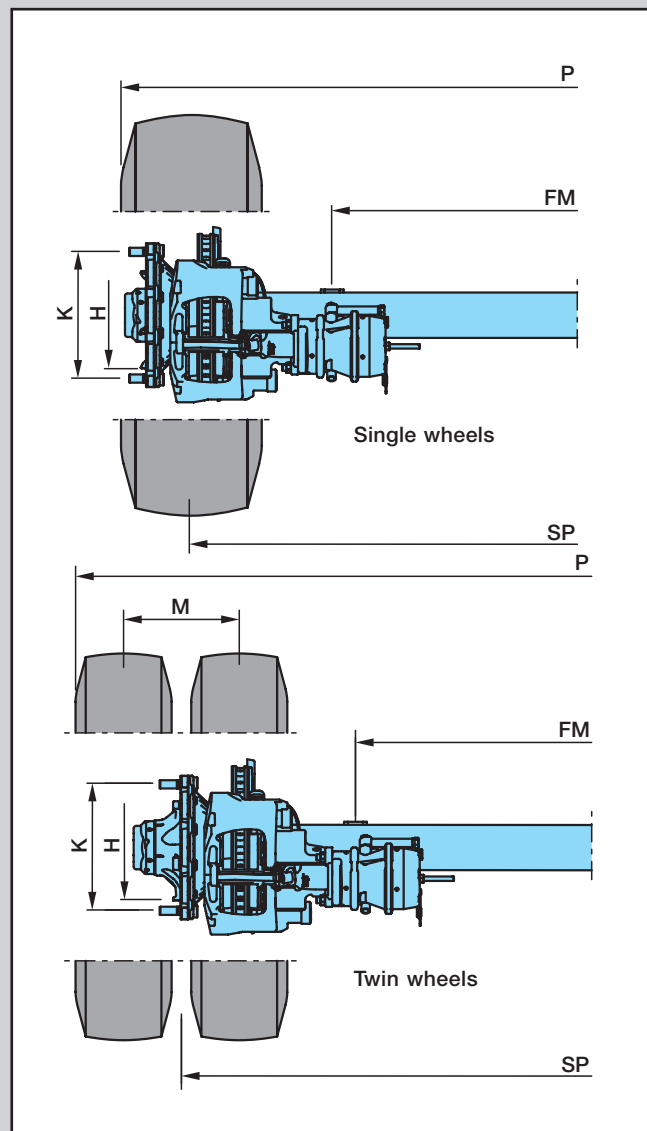

1.2 Axle beam, steering axle beam, steering pivots, steering pivot bearing

Rigid axles

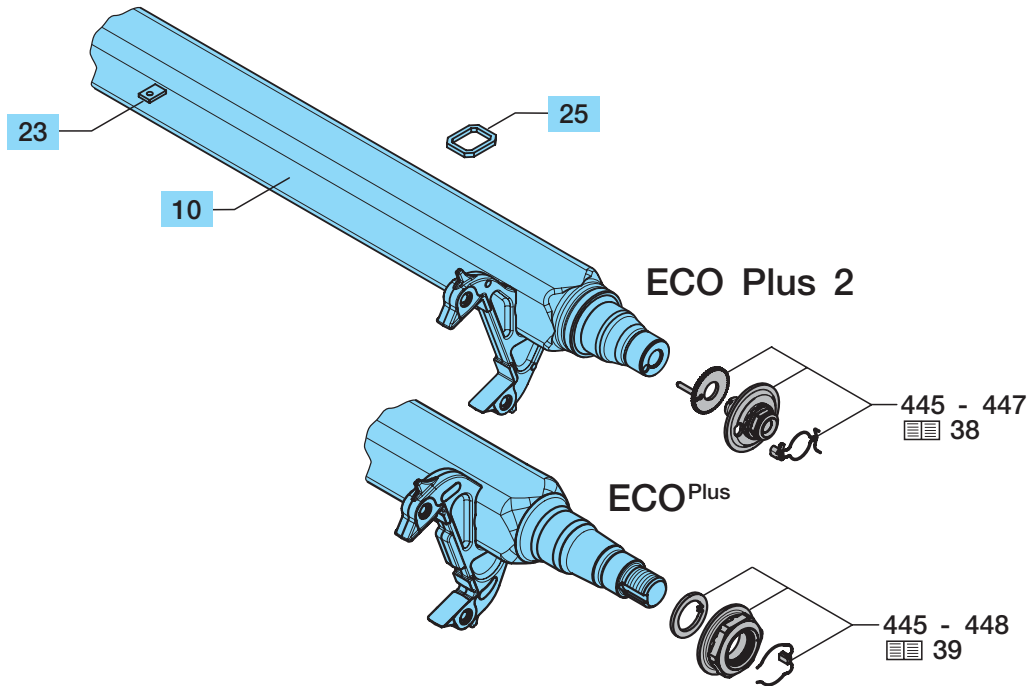

Steering axles (Series LL)

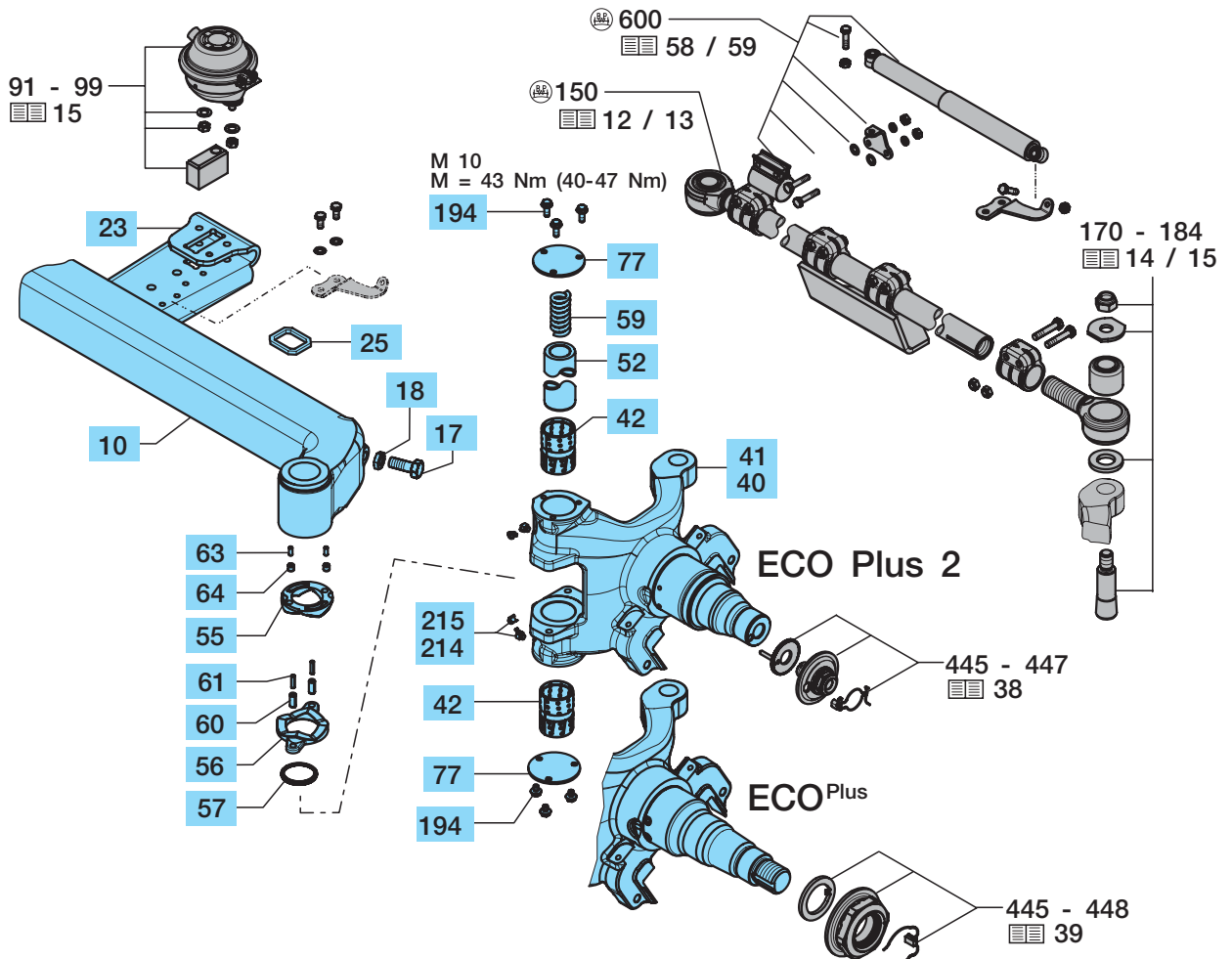



## Axle beam, steering axle beam, steering pivots, steering pivot bearing 1.2

Item	Designation (Remark)	BPW Code no.	Dimension	
<b>Rigid axles</b>				
10	Axle beam assembly	When ordering axle beam assembly, please state axle type and BPW code-no. (axle type plate).		
23	Plate (Attachment air suspension valve)	03.281.42.03.0		
25	Centering frame (for clamped axle spring seat assembly)	03.295.46.21.0	72,5 x 60 x 8	For other spring plate designs, see the spares catalogues for the corresponding suspension units.
<b>Steering axles (Series LL)</b>				
10	Steering axle beam assembly	When ordering steering axle beam assembly, please state axle type and BPW code-no. (axle type plate).		
17	Hexagon bolt	02.5026.64.80	M 20 x 50 - 8.8	
		02.5037.61.80	M 20 x 60 - 8.8	
		02.5026.69.80	M 20 x 70 - 8.8	
		03.340.13.19.0	M 20 x 70 - 8.8	
18	Hexagon nut	02.5205.09.04	M 20	
23	Shaped plate (Attachment steering lock cylinder)	upon request		
25	Centering frame	03.295.46.21.0	72,5 x 60 x 8	For other spring plate designs, see the spares catalogues for the corresponding suspension units.
40	Steering pivot assembly, right	When ordering steering pivot assembly, please state axle type, BPW code-no. (axle type plate) and side (right or left).		
41	Steering pivot assembly, left			
42	Bush	03.112.76.08.0	Ø 60 / 65 x 90	
45	Repair kit steering bolt (item 42 , 52 - 64, 214)	09.801.02.35.0		
52	Steering bolt	03.240.08.04.0	Ø 39 / 60 x 331	
55	Thrust washer, upper	03.128.05.07.0	Ø 64 / 99 x 18,5	
56	Thrust washer, lower	03.128.05.06.0	Ø 64 / 99 x 18,5	
57	Seal	02.5681.03.00	Ø 70 / 62 / 59 x 5	
59	Pressure spring	03.125.07.10.1	Ø 30 / 38 x 86 / Ø 8	
60	Roll pin	02.6006.95.90	Ø 12 x 28	
61	Roll pin	02.6016.01.90	Ø 7 x 28	
63	Roll pin	02.6016.00.90	Ø 7 x 18	
64	Roll pin	02.6016.11.90	Ø 12 x 12	
77	Washer	03.320.66.04.0	Ø 100 x 4,75 / 3xØ11	
194	Locking bolt	02.5070.60.02	M 10 x 12	
		02.5070.63.02	M 10 x 25	
214	Grease nipple	02.6802.06.50	BM 10 x 1 / 45°	
215	Cap	02.3505.20.00		

## 2.1 Steering axle, steering lock

View

### General

#### BPW Steering axles series LL

No one wants to lose rubber from their tyres every time they turn a corner. So we've developed an axle which allows your tyres to roll instead of slide.

#### The BPW LL self-steering axle

The enormous advantages of the steering axle come to the fore when manoeuvring: Better manoeuvrability, reduced wear on all tyres and less fuel consumption.

As a result, the BPW self-steering axle is the right economical solution for delivery and distribution traffic chiefly consisting of journeys in congested conurbations and cities.

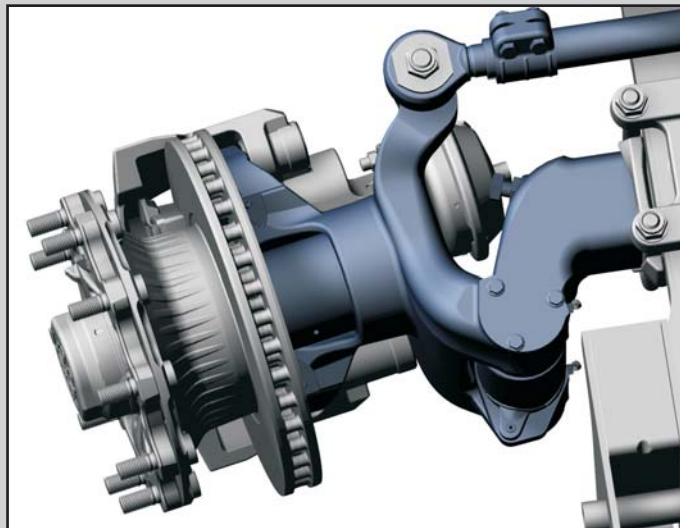

### Function

LL stands for “**load-dependent steering stabilisation**” and it describes the unique functional principle of the BPW self-steering axle.

Conventional steering axle designs require steering stabilisers powered from an external source – this is not the case with the BPW self-steering axle. The axle beam and axle stub are connected to undulating thrust bearings via steering pivots.

When driving straight ahead (zero position), the undulations in the thrust washers keep the wheels on track. The weight of the vehicle presses the undulating contours of the upper and lower thrust washers together. The wheels remain stable in the correct straight-ahead position.

When the semi-trailer follows the tractor unit into a curve, the wheel castor action ensures the wheels turn in accordance with the curve radius (the thrust washers slide over one another).

The frictional resistance changes according to the load on the axle. As a result, a steering angle (of 8 to 27°, depending on the axle type) is achieved according to the load, and is entirely controlled by mechanical means.

The link connecting the wheels uses a steering lock to prevent the wheels from steering when the vehicle is reversing.

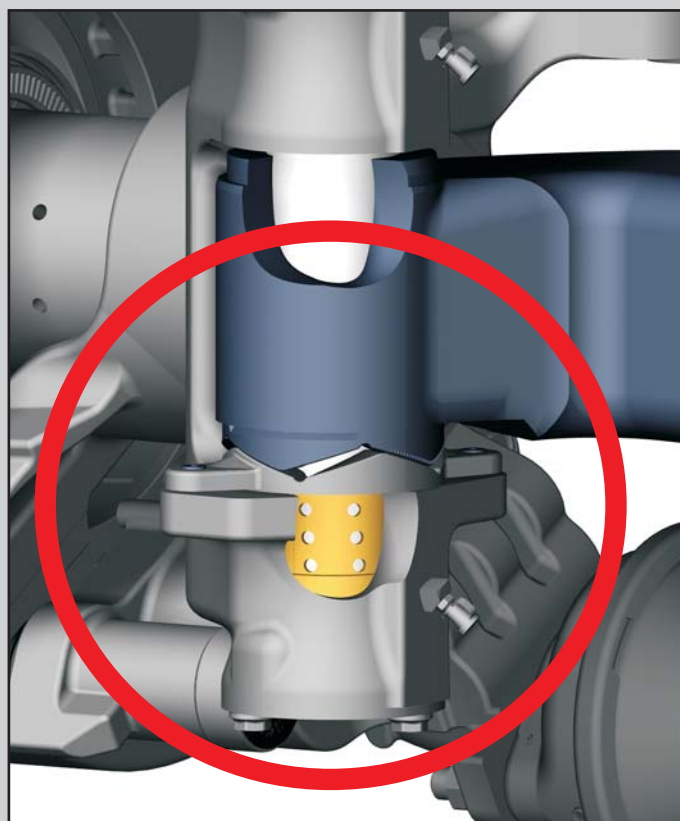

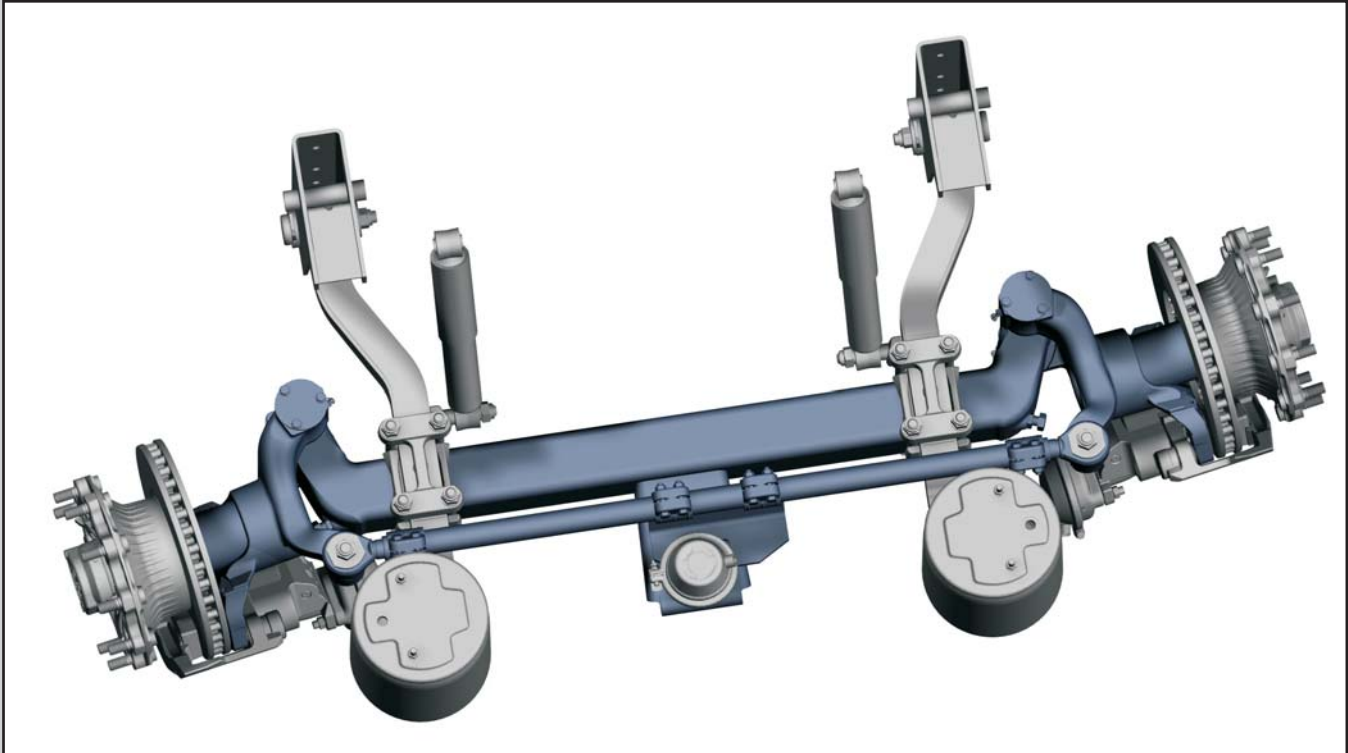

The effect of the steering axle is that the suspension unit steers into corner better and virtually follows in the tracks of the tractor unit.

The lateral forces on the tyres, occurring for example in the case of a three-axle trailer, are thus ideally distributed between all the axles.

As a result of the fact that each axle experiences considerably lower lateral forces, the mileage covered by the tyres is demonstrably increased by up to 50 % on the front axle and actually up to 70 % on the rear axle.

The use of the BPW steering axle delivers absolutely even wear.

2.2 Steering rods

Steering rods, spare parts for steering rods

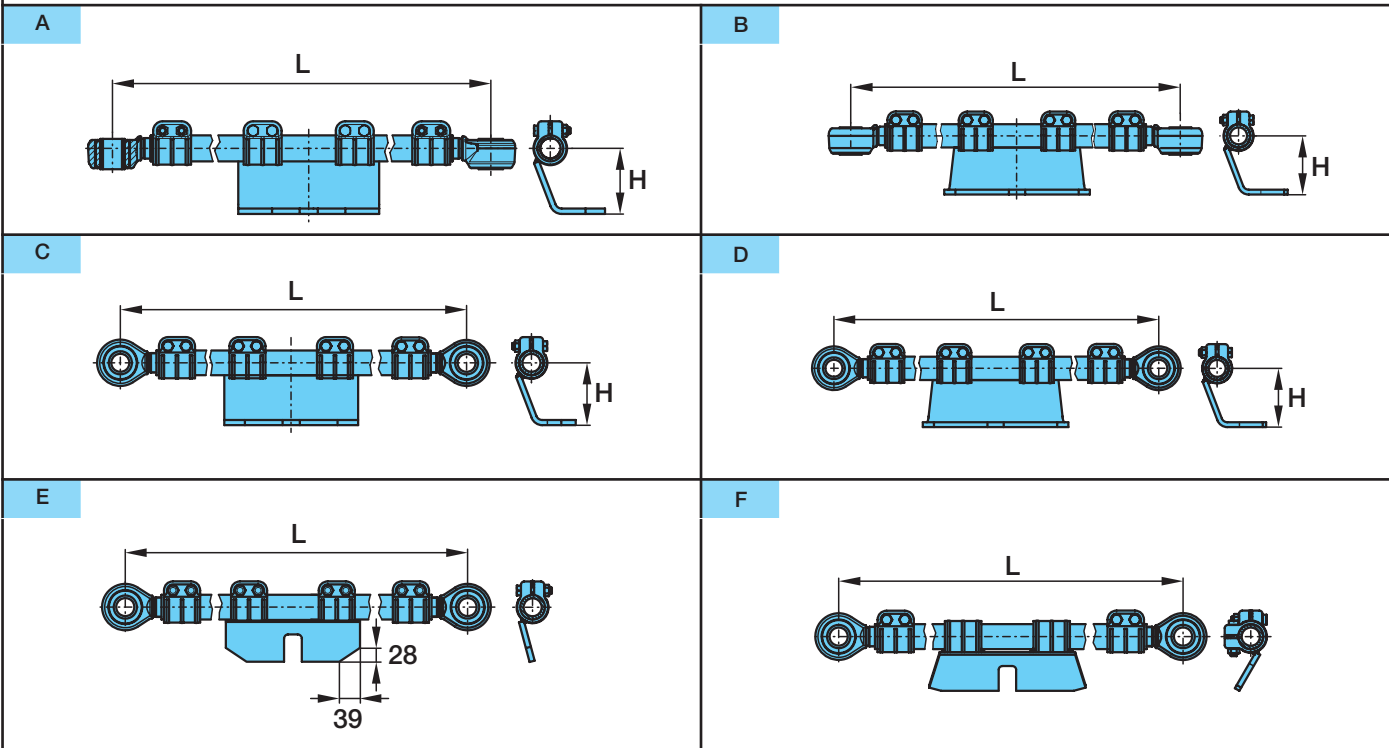
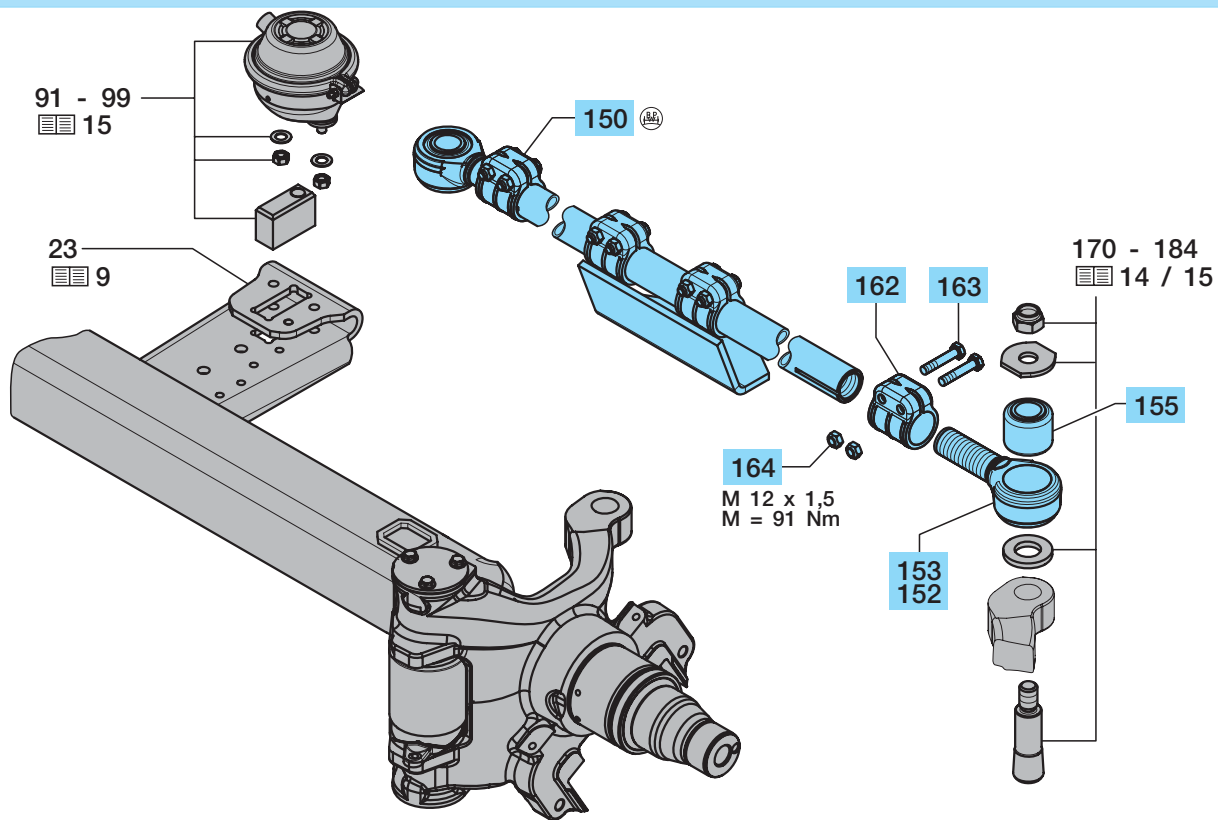

**Steering rods, spare parts for steering rods**

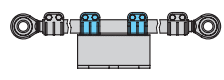
Item	Designation (Remark)	Dimension / Remark		BPW Code no.	
					
		<b>L</b>	<b>H</b>	<b>2 clamps</b>	
150	Steering rod complete incl. item 152, 153, 162 - 164	1180 ( 1160 - 1199 )	121	05.246.46.55.0	A
			129	05.246.46.30.0	A
		1220 ( 1200 - 1239 )	129	05.246.46.34.0	A
			1260 ( 1240 - 1279 )	121	05.246.46.64.0
		129		05.246.46.39.0	A
		1300 ( 1280 - 1319 )	121	05.246.46.54.0	A
			129	05.246.46.29.0	A
		1340 ( 1320 - 1359 )	-	05.246.41.06.0	E
			121	05.246.46.56.0	A
			129	05.246.46.31.0	A
		1380 ( 1360 - 1399 )	-	05.246.41.02.0	E
			121	05.246.46.52.0	A
			129	05.246.46.27.0	A
		1420 ( 1400 - 1439 )	-	05.246.41.01.0	E
			-	05.246.49.26.0	F
			121	05.246.46.51.0	A
			121	05.246.49.51.0	D
			129	05.246.46.26.0	A
			129	05.246.49.77.0	D
			150	05.246.46.77.0	C
		1460 ( 1440 - 1479 )	-	05.246.41.05.0	E
			121	05.246.46.61.0	A
			129	05.246.46.36.0	A
			129	05.246.49.81.0	D
		1500 ( 1480 - 1519 )	-	05.246.41.03.0	E
			-	05.246.49.28.0	F
			121	05.246.46.53.0	A
			129	05.246.46.28.0	A
129	05.246.49.79.0		D		
1520 ( 1520 - 1559 )	-	05.246.49.38.0	F		
1540 ( 1520 - 1559 )	-	05.246.41.13.0	E		
	121	05.246.46.63.0	A		
	121	05.246.49.63.0	D		
	129	05.246.46.38.0	A		
	129	05.246.49.69.0	D		
152	Track rod end assy. incl. item 155	left threaded	05.353.68.27.0		
153	Track rod end assy. incl. item 155	right threaded	05.353.68.26.0		
155	Bush	Ø 35 / 64 x 56	05.113.92.04.0		
162	Clamp		02.3507.25.00		
163	Hexagon bolt	M 12 x 1.5 x 60 - 8.8	02.5029.35.80		
164	Lock nut	VM 12 x 1.5 - 8	02.5220.15.82		

2.3 Steering rod attachments

Steering rod attachments	
Track rod position 24.5 mm	Track rod position 25 mm
<p><b>A</b></p> <p>M 24 M = 550 Nm 184 178 171 X = 24.5</p>	<p><b>B</b></p> <p>171 173 178 184 M 24 M = 550 Nm X = 25</p>
Track rod position 35 mm	Track rod position 45 mm
<p><b>C</b></p> <p>171 173 178 184 M 24 M = 550 Nm X = 35</p>	<p><b>D</b></p> <p>171 178 184 M 24 M = 550 Nm X = 45</p>
Track rod position 171 mm	Track rod position 171 mm
<p><b>E</b></p> <p>M 24 M = 550 Nm 184 178 171 X = 171</p>	<p><b>F</b></p> <p>M 24 M = 550 Nm 184 178 173 171 X = 171</p>
Track rod position 163 mm	Track rod position 190 mm
<p><b>G</b></p> <p>M 24 M = 550 Nm 184 178 171 X = 163</p>	<p><b>H</b></p> <p>M 24 M = 550 Nm 184 178 173 171 X = 190</p>

## Steering rod attachments, steering lock 2.3

Steering rod attachments			
Item	Designation (Remark)	BPW Code no.	Dimension
			<b>Track rod position 24.5 mm      A</b> <b>Track rod position 45 mm        D</b> <b>Track rod position 163 mm       G</b>
170	Assembly kit item 171 - 184	05.801.43.18.1	
171	Threaded bolt	03.177.04.05.0	Ø 40 / 35 / M 24 x 138
178	Washer	03.320.24.05.0	Ø 24.5 / 70 x 65 x 6
184	Lock nut	02.5220.74.12	VM 24 / 980 - 10
			<b>Track rod position 25 mm        B</b>
170	Assembly kit item 171 - 184	05.801.43.51.1	
171	Threaded bolt	03.177.04.14.0	Ø 40 / 35 / M 24 x 163
173	Ring	03.310.03.22.0	Ø 35 / 40 / 65 x 25
178	Washer	03.320.24.05.0	Ø 24.5 / 70 x 65 x 6
184	Lock nut	02.5220.74.12	VM 24 / 980 - 10
			<b>Track rod position 35 mm        C</b> <b>Track rod position 190 mm       H</b>
170	Assembly kit item 171 - 184	05.801.43.19.1	
171	Threaded bolt	03.177.04.06.0	Ø 40 / 35 / M 24 x 153
173	Ring	03.310.03.06.0	Ø 35 / 40 / 65 x 15
178	Washer	03.320.24.05.0	Ø 24.5 / 70 x 65 x 6
184	Lock nut	02.5220.74.12	VM 24 / 980 - 10
			<b>Track rod position 171 mm       E</b>
170	Assembly kit item 171 - 184	05.801.43.50.1	
171	Threaded bolt	03.177.14.40.0	Ø 40 / 35 / M 24 x 118
184	Lock nut	03.260.56.03.0	M 24 - 10
			<b>Track rod position 171 mm       F</b>
170	Assembly kit item 171 - 184	05.801.43.47.1	
171	Threaded bolt	03.177.04.13.0	Ø 40 / 35 / M 24 x 146
173	Washer	03.320.33.24.0	Ø 35 / 64 x 8
178	Washer	03.320.24.05.0	Ø 24.5 / 70 x 65 x 6
184	Lock nut	02.5220.74.12	VM 24 / 980 - 10
Track rod position = Distance axle centre - steering rod centre			

Steering lock			
Item	Designation (Remark)	BPW Code no.	Dimension
			<b>SH..LL. / SK..LL..</b>
91	Cylinder incl. item 98 + 99	02.0327.38.00	
96	Lock	03.060.00.13.0	
98	Spring washer	02.5601.12.90	A 12
99	Hexagon nut	02.5202.16.80	M 12 - 8

3.1 Brake parts BPW ECO Disc TSB 3709 / 4309 / 4312

View

**General**

Brakes that are under utilised glaze up and their braking effort is reduced. Over utilisation causes disproportionate wear.

Correct selection and dimensioning of the brake is therefore of crucial significance.

BPW offers you the correct brake for every application.

**BPW ECO Disc Trailer disc brake (TSB) 3709 (Ø 370)**

For versatile deployment in the haulage business under normal conditions (e.g. long-distance road haulage in Western Europe).

- Axle load: 9 – 10 t
- Tyre size: 19.5" ( 9 + 10 t )  
22.5" ( 9 t )
- Wheel exec. : E, Z, ET 0  
ET 120 ( only 9 t )

**BPW ECO Disc Trailer disc brake (TSB) 4309 (Ø 430)**

For conditions that demand greater disc and pad volume, such as mountainous routes, frequently changing tractor-trailer combinations, when deployed in Eastern Europe or in regional distribution.

- Axle load: 9 – 10 t
- Tyre size: 22.5"
- Wheel exec.: E, Z, ET 0;  
ET 120 ( only 9 t )

Advantage: Large diameter brake discs and calliper matching the axle load.

**BPW ECO Disc Trailer disc brake (TSB) 4312 (Ø 430)**

For axle loads above 10 tonnes.

- Axle load: 11 – 12 t
- Tyre size: 22.5"
- Wheel exec.: E, Z, ET 0

E = Single wheels  
Z = Twin wheels  
ET = Offset

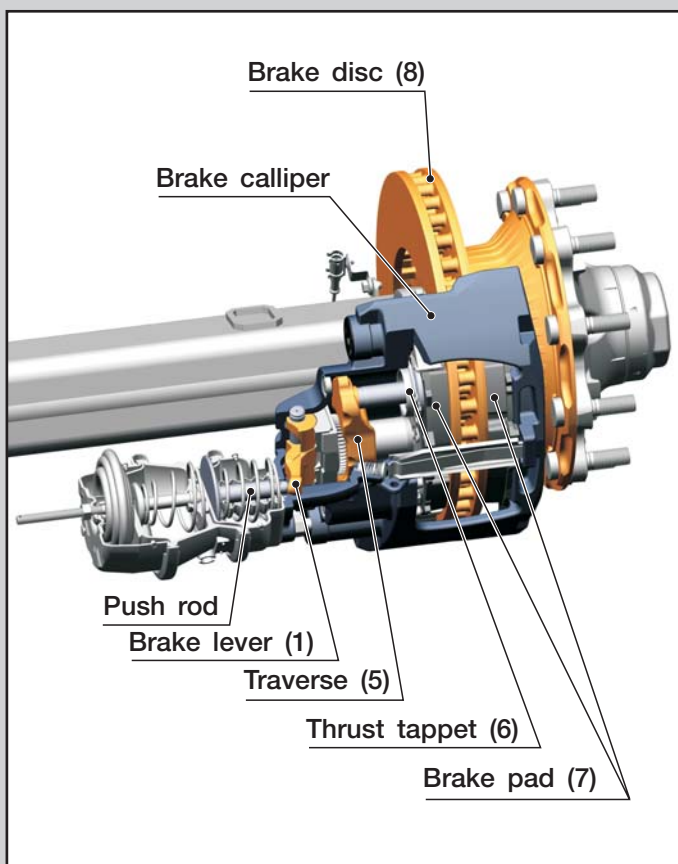



**Type plate**

There is a manufacturer's nameplate fixed onto each brake calliper, on which are stamped the data necessary for the identification of the brake in question.

- BPW Brake code number
- Brake type + serial number
- For replacement, brake calipers will only be supplied as a complete replacement brake caliper ( 09 362 ..... ) with complete lining set.

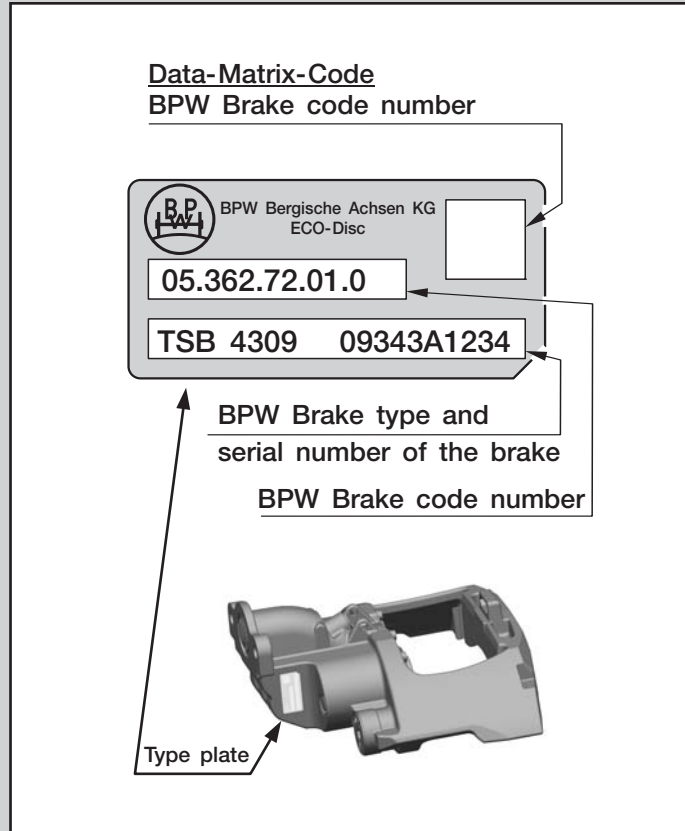

## 3.1 Brake parts BPW ECO Disc TSB 3709 / 4309 / 4312

View

## BPW ECO Disc Trailer disc brake TSB 3709 / 4309 / 4312

**OPERATING PRINCIPLE: SLIDING CALLIPER BRAKE****APPLYING THE BRAKE**

During braking, the cylinder pushrod of the spring brake or diaphragm cylinder presses onto the brake lever (1).

The offset position of the brake lever amplifies the force created by the brake cylinder and allows it to be transferred to the intermediate plate (2) with minimal loss via a needle bearing.

Mounted in the pressure plate (4), the intermediate plate counteracts the vertical movement of the lever and ensures optimal transfer to the cross support.

The clamping force acts on the inner brake pad (7a) via the cross support (5) and the pressure plates (6). Once the play between the inner brake pad and the brake disc (8) has been overcome, the reaction force is transferred to the outer brake pad (7b) via the brake calliper.

The brake torque for the wheel is generated when the brake pads contact the brake disc.

The radial stabilizer force created by the responding brake pad at this time is transferred directly to the axle via the brake calliper.

**RELEASING THE BRAKE**

When brake pressure rises, the pressure spring (9) moves the actuating unit back to its initial position.

**ADJUSTMENT**

The brake is fitted with an automatic non-wearing adjusting device (10) to maintain constant clearance between the brake pad and the brake disc.

Each time the brake is operated the axial movement of the lever block (2) and pressure plate (4) causes the adjuster pin (11) to be rotated via a trapezoidal thread.

The adjuster pin is connected to the threaded tube (14) by the movement thread (11a) which in turn can rotate the threaded tube (14) via the spring loaded indented ball coupling sleeve (12). When play increases the threaded tube (14) is turned correspondingly via the indented ball coupling (12).

Axial play in the trapezoidal thread between the pressure plate (4) and the adjuster pin determines the free play value of the disc brake.

When the free play is set correctly the spring loaded indented ball coupling sleeve (12) can disengage without turning the threaded tube (14).

The overall play (total play on both sides of the disc brake) measures 0.8 mm +/- 0.2 mm.

**RESET MECHANISM**

The disc brake features a reset mechanism at the front for replacing the brake pads and brake disc.

The return spring gear wheel (13) is mechanically connected to the external gearing of the threaded tube (14) so that the pressure plates (6) can return to their initial position. Only minimal torque is required to move the pressure plates (6) back to this position or preset the play.

**BRAKE CYLINDER**

Air pressure builds up behind the diaphragm due to the action of compressed air on the brake cylinder.

Air pressure forces the thrust rod out of the cylinder via the diaphragm plate.

The brakes may only be fitted with brake cylinders which, apart from the sealing of the flange surface, are fitted with a so called "inner sealing".

This means that the pushrod acting on the lever (1) must be hermetically sealed from the secondary chamber of the brake cylinder as otherwise the internal mechanism is completely open to its surroundings.

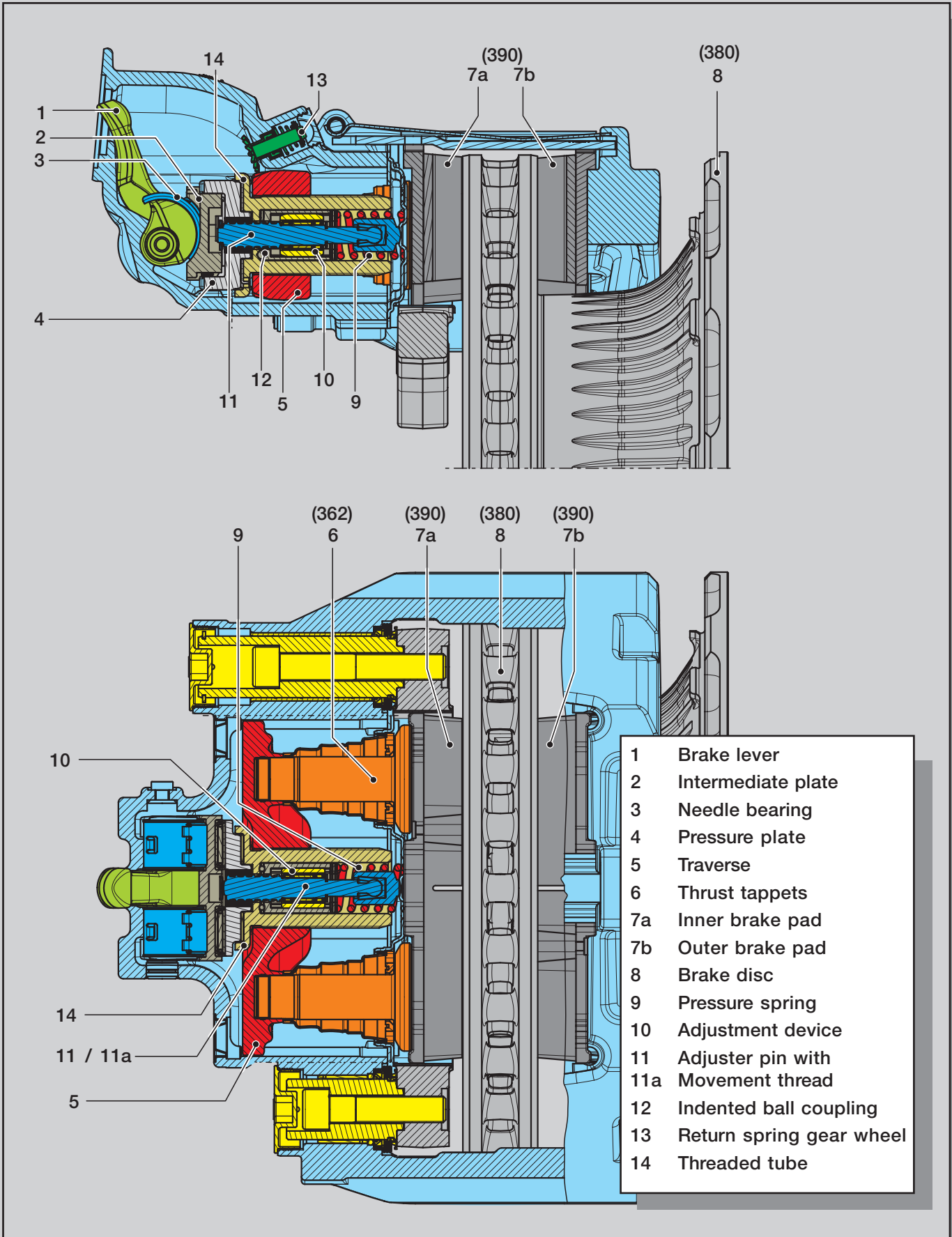

3.2 Brake parts BPW ECO Disc TSB 3709 / 4309 / 4312

BPW ECO Disc TSB 3709

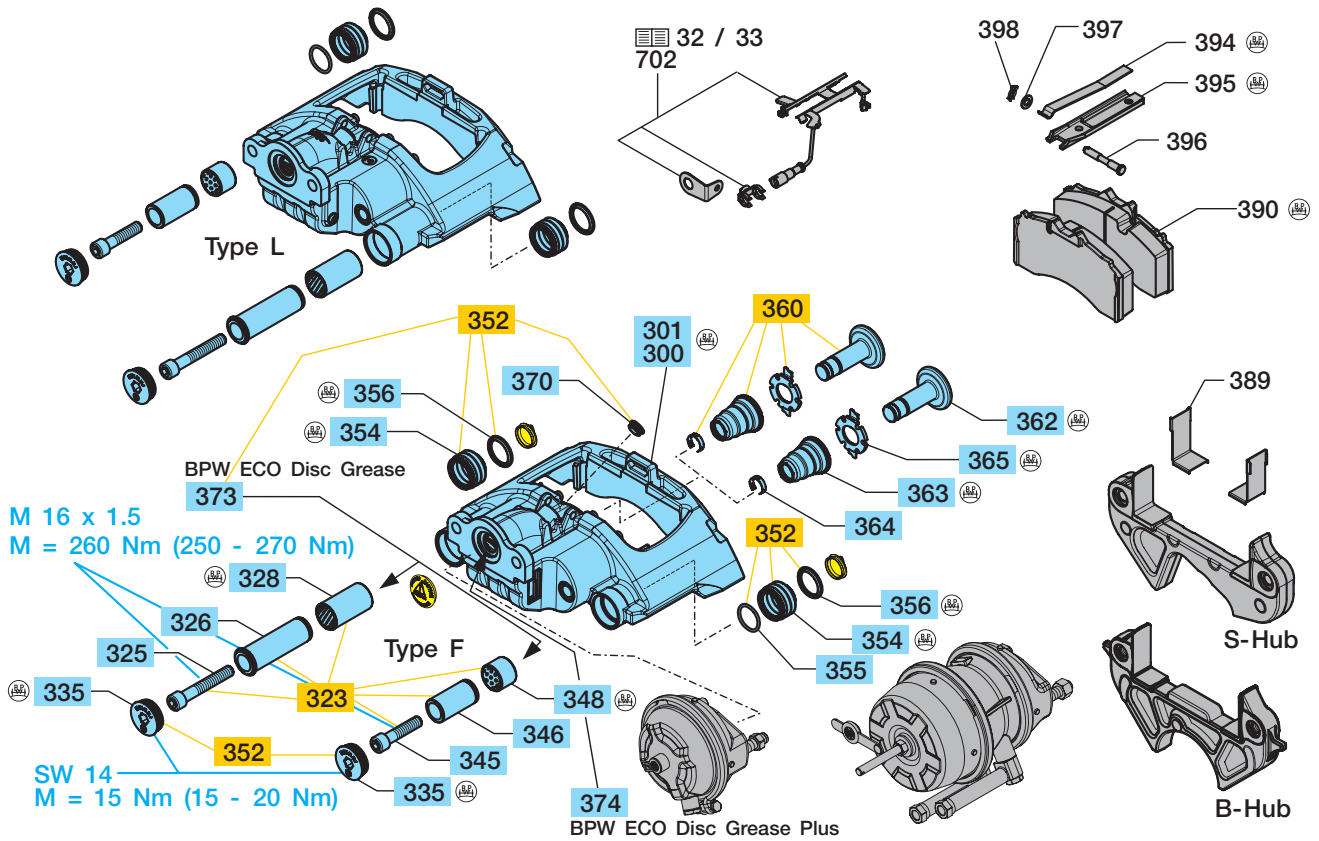

BPW ECO Disc TSB 4309 / 4312

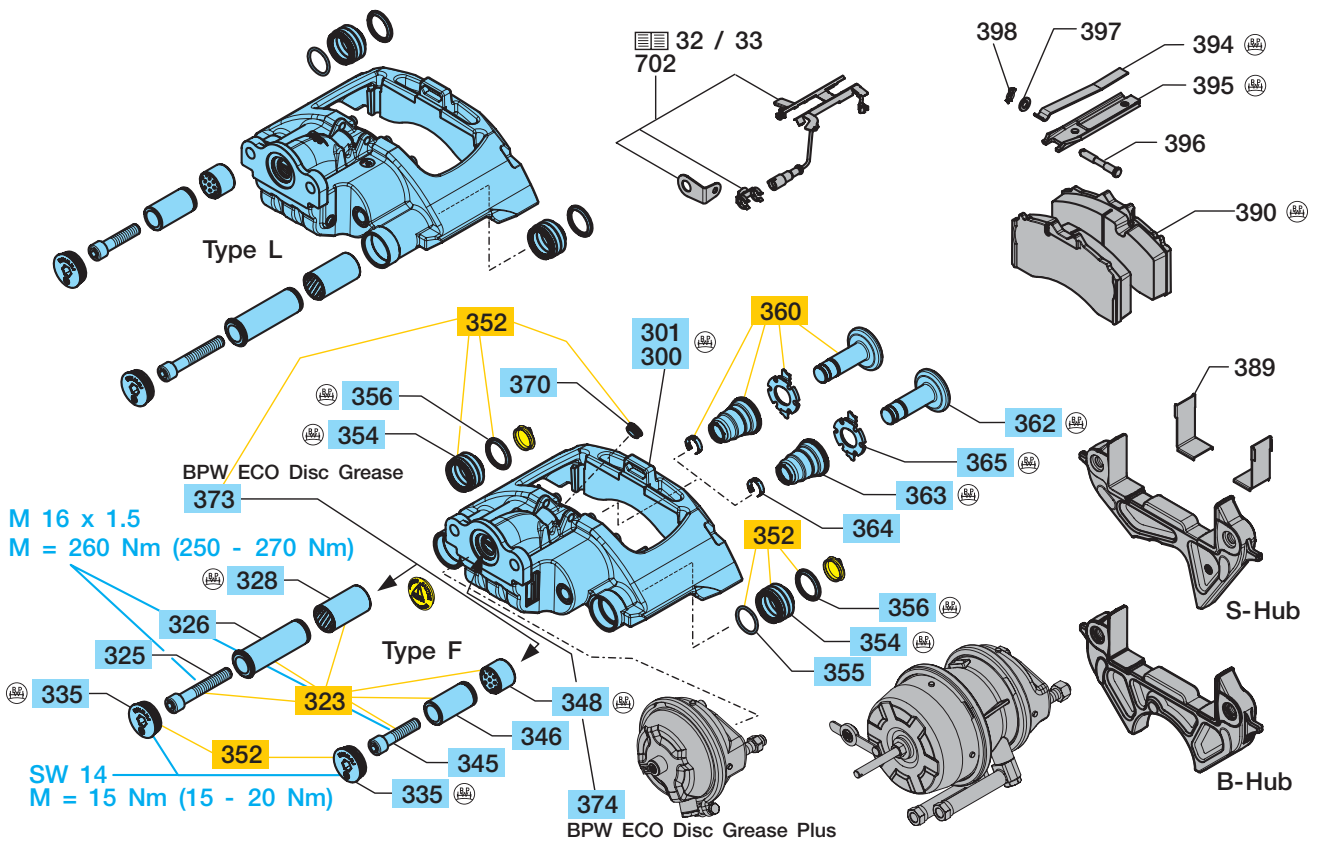

## Brake parts BPW ECO Disc TSB 3709 / 4309 / 4312 3.2

BPW ECO Disc TSB 3709 / 4309 / 4312					
			TSB 3709 ---.616.---	TSB 4309 ---.617.---	TSB 4312 ---.618.---
Item	Designation (Remark)	Dimension / Remark	BPW Code no.		
300 301	BPW replacement brake calliper cpl. ( pre-greased ) incl. guide pins, brake pads and attachment parts. <b>Order screws for steering axles (item 325 + 345) separately.</b>	Type L / BPW 8200 Type F / BPW 8200 Type L / BPW 8101 Type F / BPW 8101 Type L / BPW 8301 Type F / BPW 8301	09.362.72.03.0 <sup>1)</sup> 09.362.72.04.0 <sup>1)</sup> 09.362.72.03.1 <sup>1)</sup> 09.362.72.04.1 <sup>1)</sup> - -	09.362.72.01.0 <sup>1)</sup> 09.362.72.02.0 <sup>1)</sup> 09.362.72.01.1 <sup>1)</sup> 09.362.72.02.1 <sup>1)</sup> - -	- - - - 09.362.72.05.0 <sup>1)</sup> 09.362.72.06.0 <sup>1)</sup>
323	Repair kit guide pins item 325, 326, 328, 345, 346, 348, 373	for one axle side	09.801.07.61.0		
325 326 328 335 345 346 348	Cylinder head screw Guide pin, long (fixed bearing) Guide bush (fixed bearing) Sealing cap Cylinder head screw Guide pin, short (floating bearing) Guide bush (floating bearing)	M 16 x 1.5 x 100 - 10.9 M 16 x 1.5 x 105 - 10.9 Ø 17 / 26 / 37 x 123 Ø 37 / 41 x 73 M 49 x 1.5 M 16 x 1.5 x 70 - 10.9 M 16 x 1.5 x 75 - 10.9 Ø 17 / 26 / 36 x 70 Ø 37 / 41 x 30		02.5016.70.16 03.340.12.30.0 05.001.00.41.0 03.112.33.13.0 05.001.00.45.0 02.5015.78.16 03.340.12.29.0 03.001.00.35.0 03.112.33.14.0	for rigid axle for steering axle <sup>2)</sup>    for rigid axle for steering axle <sup>2)</sup>
352	Repair kit seal for guide pins item 335, 354, 355, 356, 370, 373	for one axle side	09.801.07.62.0		
354 355 356	Bellow 'O'-Ring Ring	Ø 52 x 34 Ø 36 x 3.5 Ø 38 / 48 x 5	05.130.08.27.0 02.5679.98.40 03.310.11.19.0		
360	Repair kit tappet item 362 - 365	for one axle side	09.801.07.63.0		
362 363 364 365	Tappet Bellow Holding clamp Dirt seal	Ø 24 / 27 / 84.5 x 94.5 Ø 26 / 55 x 17 Ø 25 x 7 Ø 55 x 1.5	03.127.18.02.0 05.130.07.07.0 03.001.57.01.0 03.121.30.15.0		
370	Plug	Ø 24 x 9	02.3704.69.00		
373	BPW ECO Disc Grease	25 g	02.1040.60.00		
374	BPW ECO Disc Grease Plus *	5 g	02.1040.61.00		

\* Grease the spherical cap in the lever with BPW ECO Disc Grease Plus.

<sup>1)</sup> For replacement, brake calipers will only be supplied as a complete replacement brake caliper ( 09 362 ..... ) with complete lining set.

<sup>2)</sup> Not included in the BPW replacement brake caliper 09.362..... . Order screws separately!

3.2 Brake parts BPW ECO Disc TSB 3709 / 4309 / 4312

BPW ECO Disc TSB 3709

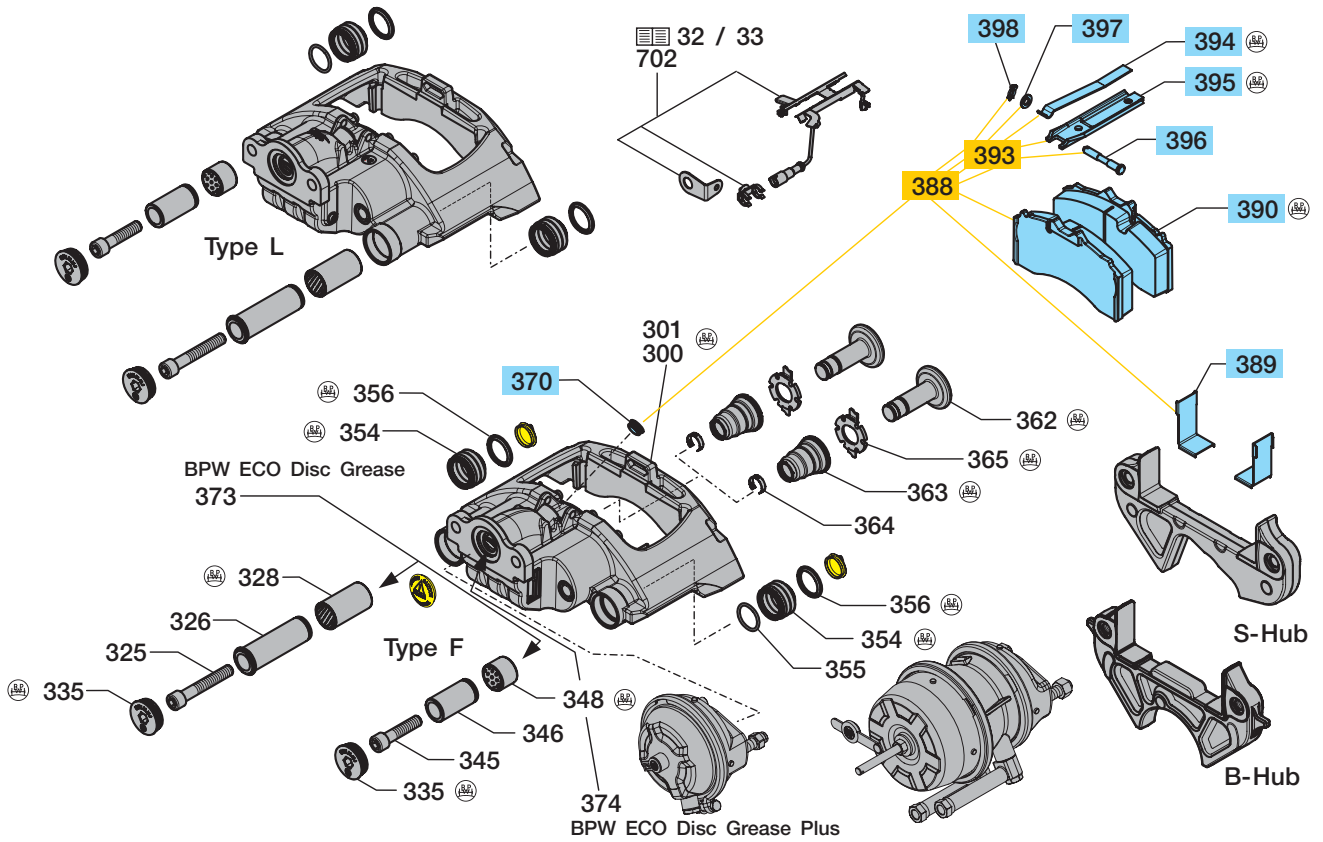

BPW ECO Disc TSB 4309 / 4312

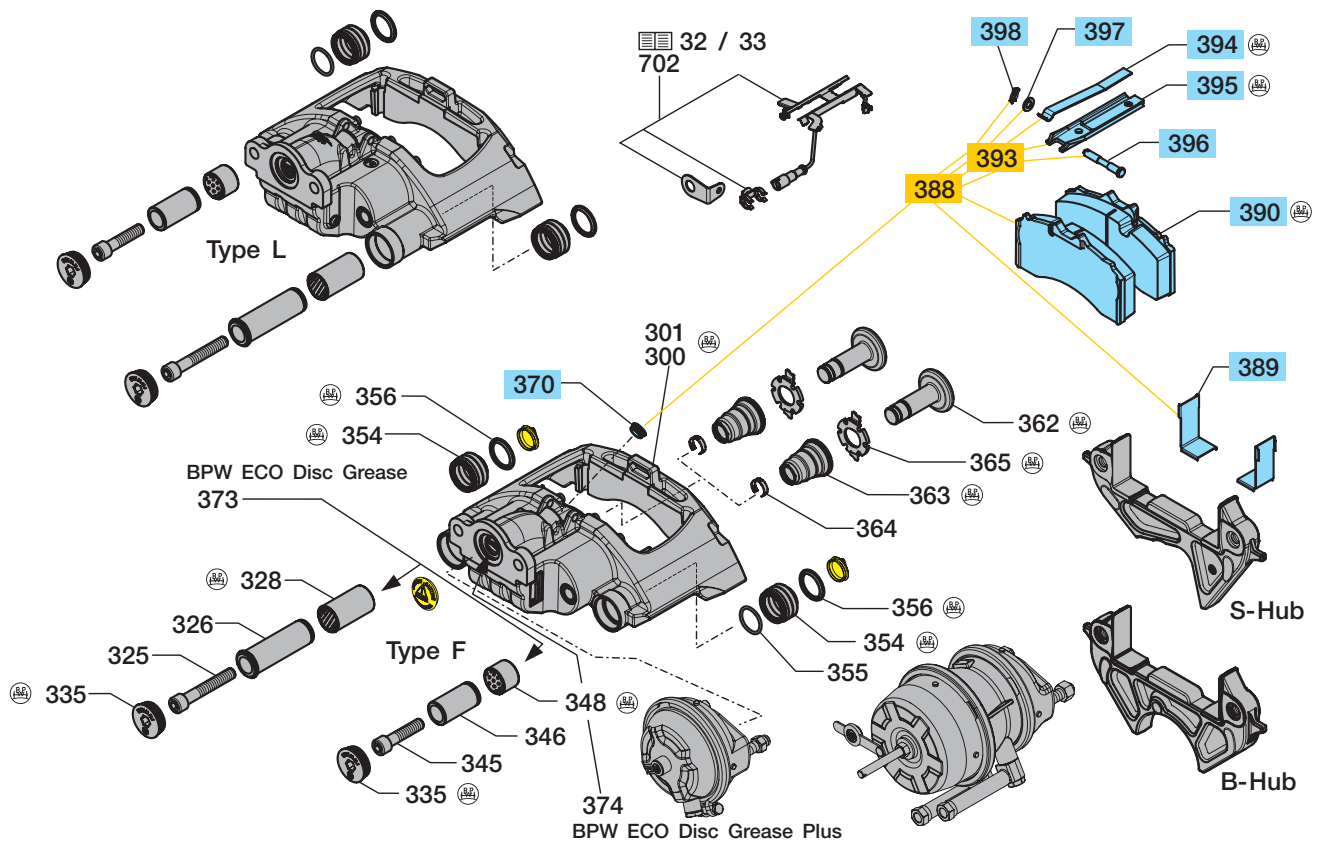

## Brake parts BPW ECO Disc TSB 3709 / 4309 / 4312 3.2

BPW ECO Disc TSB 3709 / 4309 / 4312					
			TSB 3709 ---.616.---	TSB 4309 ---.617.---	TSB 4312 ---.618.---
Item	Designation (Remark)	Dimension / Remark	BPW Code no.		
388	Repair kit brake lining ( BPW 8200 ) ( BPW 8101 ) ( BPW 8301 ) item 370, 389, 390, 394, 396 - 398	for one axle	09.801.07.55.0 09.801.07.56.1 -	09.801.07.57.0 09.801.07.58.1 -	- 09.801.07.60.1 09.801.07.59.0
389 390	Wearing plate Brake lining *	BPW 8200 BPW 8101 BPW 8301	03.163.04.02.0 05.092.90.12.0 * 05.092.90.15.0 *	03.163.04.03.0 05.092.90.13.0 * 05.092.90.16.0 *	03.163.04.04.0 - - 05.092.90.20.0 *
393	Repair kit brake retaining clip item 394 - 398	for one axle	09.801.07.68.0		
394 395 396 397 398	Clamping spring Pad holding bar Bolt Washer Lock	Ø 8 / 10 / 14 x 75 Ø 10.5 vzkt	03.352.00.08.0 03.001.00.54.0 03.084.32.33.0 02.5404.10.04 02.3301.31.00		
* Only deliverable per kit (item 388)!					

### 3.3 Brake discs

View

#### BPW Brake discs

With the introduction of IBD brake discs, the proven BPW design of the collar disc has been further improved.

Further development has focused on the regulation of thermal efficiency in order to optimise wear characteristics and to improve reliability.

The quality of brake discs is the result of a combination of the shape of the design, the materials used and the quality of the mechanical machining.

The chemical composition of the material alloy is in particular responsible for a large number of properties, and hence determines some essential product features.

BPW has taken these technological influences into account for many years in the development of brake discs, matching them to the requirements on the trailer.

BPW Brake disc - IBD version

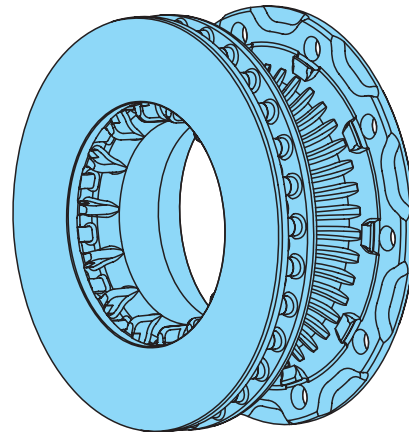

The latest generation of BPW brake discs offers the following advantages:

- Increased surface area for effective heat dissipation
- Optimisation of material for improved heat distribution over the surface of the disc
- Venuri contour for improved internal air flow
- Optimally matched friction pairing (Pads / Brake disc)
- High resistance to wear
- Simplified spare parts provision thanks to uniform brake discs for 0 and 120 offsets



Brake discs						
Brake	BPW Code no.	Pitch circle / hole pattern	Wheel hub	Offset	Series	Remark
<b>TSB 3709</b>	03.088.34.15.7	275 / 8-hole	S, Z	0		
	03.088.34.16.7	275 / 8-hole	S, Z	0		with mounting for exciter ring
	03.088.34.14.7	335 / 10-hole	S, Z, B	0 / 120	IBD	
	03.088.34.17.7	335 / 10-hole	S	0	IBD	with mounting for exciter ring
<b>TSB 4309</b>	03.088.35.05.7	335 / 10-hole	S, Z, B	0 / 120	IBD	
<b>TSB 4312</b>	03.088.35.05.7	335 / 10-hole	S, Z	0	IBD	
			S = Single wheels, offset 0 B = Single wheels, offset 120 Z = Twin wheels			

**Wear status of the brake disc**

The brake disc is to be regularly checked for its residual thickness and any damage to the braking surface.

The residual thickness of the brake disc must not be less than the permissible minimum in any area of the disc.

Network-like heat cracking (A), radial cracks up to 1.5 mm in width and depth (B) and pitting of the braking surface less than 1.5 mm (C) are permissible.

Continuous cracks (D) are not permissible.

If the brake disc has reached its wear limit or its braking surface shows inadmissible damage, it must be replaced.

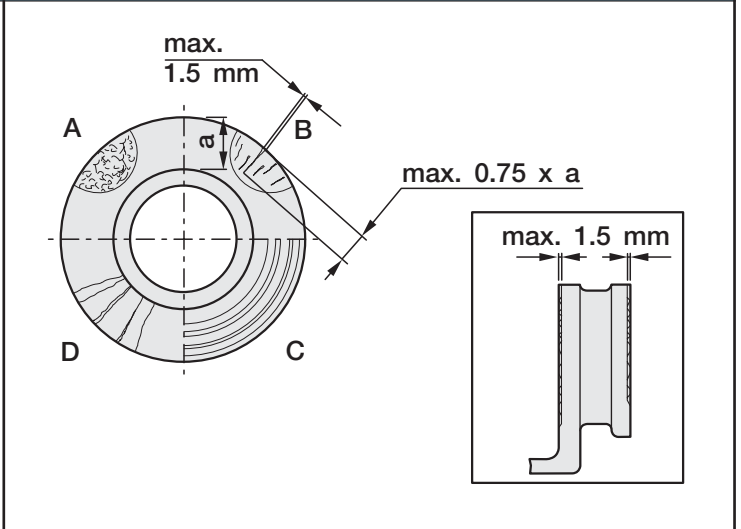

**Technical details:**

- disc thickness, new = 45 mm
  - minimum permissible disc thickness = 37 mm (check with slide gauge)
- In the case of surface conditions A - C, the brake disc can be used until the minimum permissible disc thickness has been reached.

3.5 Disc covers, brake pad protectors

BPW ECO Disc TSB 3709 / 4309 / 4312 - Rigid axles

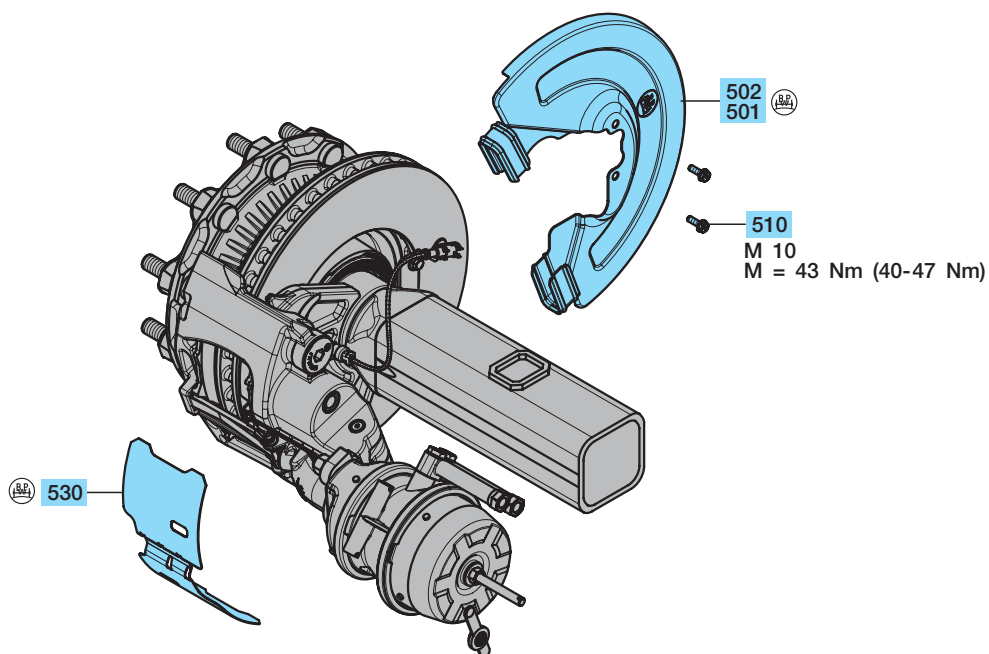

BPW ECO Disc TSB 3709 / 4309 / 4312 - Steering axles

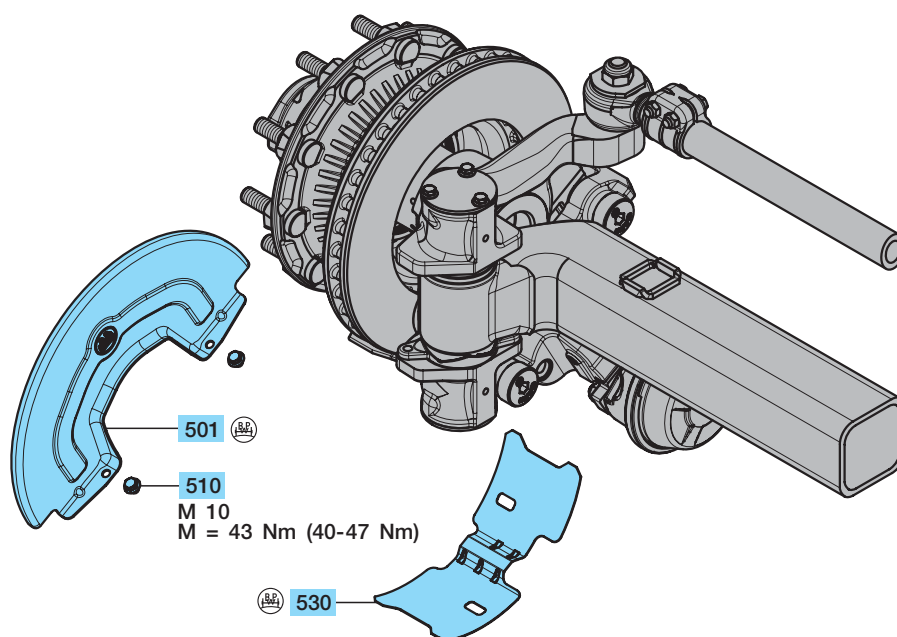

## Disc covers, brake pad protectors 3.5

Disc covers					
Item	Designation (Remark)	Dimension	BPW Code no.		
			TSB 3709 □ 120	TSB 4309 □ 120	TSB 4312 □ 150
Rigid axles					
500	Supplementary installation kit cover plates item 501 - 510	for one axle	09.801.07.51.0	09.801.07.52.0	09.801.07.53.0
501	Disc cover		03.010.71.59.0	03.010.71.61.0	03.010.71.57.0
502	Disc cover		03.010.71.60.0	03.010.71.62.0	03.010.71.58.0
510	Locking screw	M 10 x 15	02.5071.22.00	02.5071.22.00	02.5071.22.00
513	Seal	Ø 7 / 10 / 13	-	02.5681.78.00	-
Steering axles					
500	Supplementary installation kit cover plates item 501 - 510	for one axle	05.801.50.48.0	05.801.50.47.0	-
501	Disc cover		03.010.71.64.0	03.010.71.63.0	-
510	Locking screw	M 10 x 15	02.5071.22.00	02.5070.22.00	-
Brake pad protectors					
Item	Designation (Remark)	Dimension	BPW Code no.		
530	Brake pad protector *	for one axle side	03.010.95.32.0	TSB 3709 TSB 4309 TSB 4312	
* is mounted under the pad retaining clip without any additional attachment parts					

### 3.6 Brake cylinder

View

#### General

##### BPW Brake cylinder

BPW Brake cylinders come with a range of special features justifying their high quality level:

- The cylinder size and the part number are embossed on the unit
- Parts which are critical to function can be traced back through the QA system by means of their type plate data
- The extended compressed air connection makes them easy to install
- Double seals on the twin compartment
- Effective anti-corrosion protection by powder and Delta Tone coating
- Shot-peened, epoxy-coated compression springs
- Spring-type accumulator chamber in permanent, positive connection
- Long service life thanks to high-performance rubber diaphragms
- Closely sealing bellows
- Chromated aluminium housing

#### Types:

##### Diaphragm cylinders

These act as a service brake and are characterised by their compact external dimensions and low weight.

##### Diaphragm-diaphragm cylinders ( M - M )

These act both as a service brake and an auxiliary and parking brake. They are lighter than the diaphragm-piston cylinder.

##### Diaphragm-piston cylinders ( M - K )

These have the same function as a diaphragm-diaphragm cylinder.

Their greater spring accumulator force means they are particularly suitable for vehicles with higher axle loads.

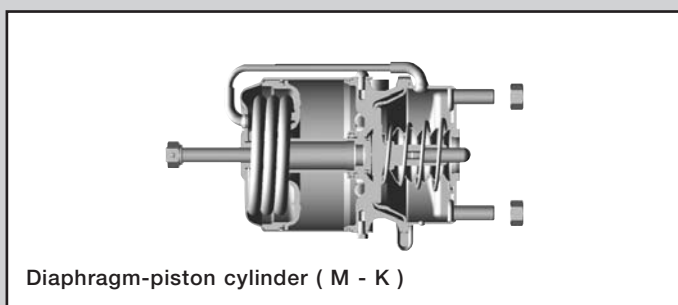
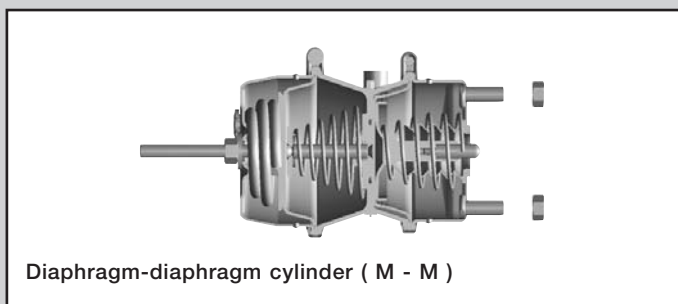
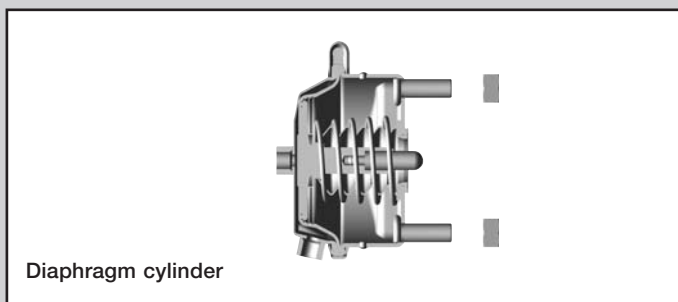

**Release device**

As of March 2004 the release bolt for M/M brake cylinders on axles with disc brakes will have a new parking position. The release bolt will no longer be accommodated in the parking pocket on the outside of the cylinder, but can be left in the cylinder cover plate.

All that is needed to use the parking position is to turn the release bolt through 90° and then lock it in place with a hex. nut.

In addition to which it is still also possible to remove the release bolt completely.

Further information can be found under the heading Aktuell / BPW NEWS / News SB 04/01 on the BPW website [www.bpw.de](http://www.bpw.de).

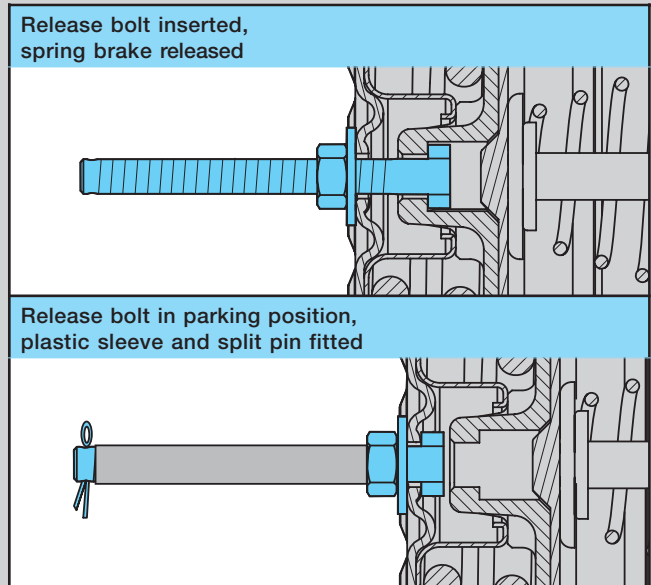

**Compressed air connection extension ( DLAV )**

Spring-type cylinders for disc brakes are fitted with a compressed air connection extension (DLAV) as standard.

A feature of DLAV is that it enables additional compressed air systems to be mounted on the axle quickly and easily.

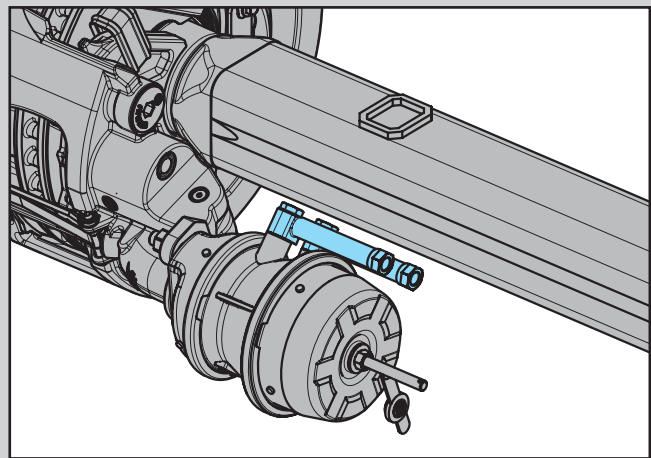

**Identification**

The BPW part number and the cylinder model are stamped on the front of every brake cylinder.

Each brake cylinder also has a manufacturer's nameplate riveted onto it, with the details of the BPW part number, cylinder type and production date.

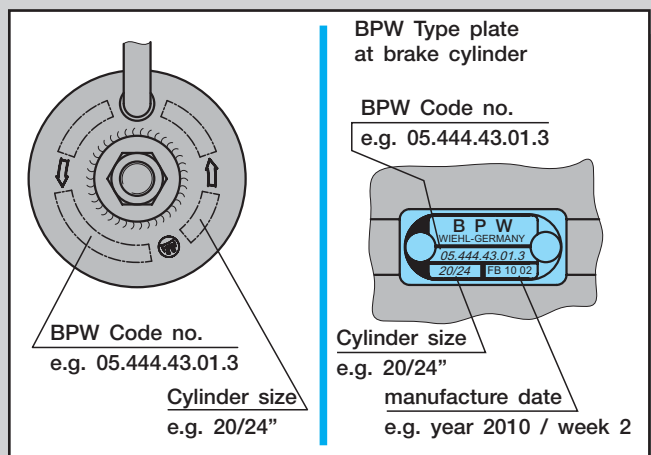

3.7 Brake cylinder

Diaphragm cylinder

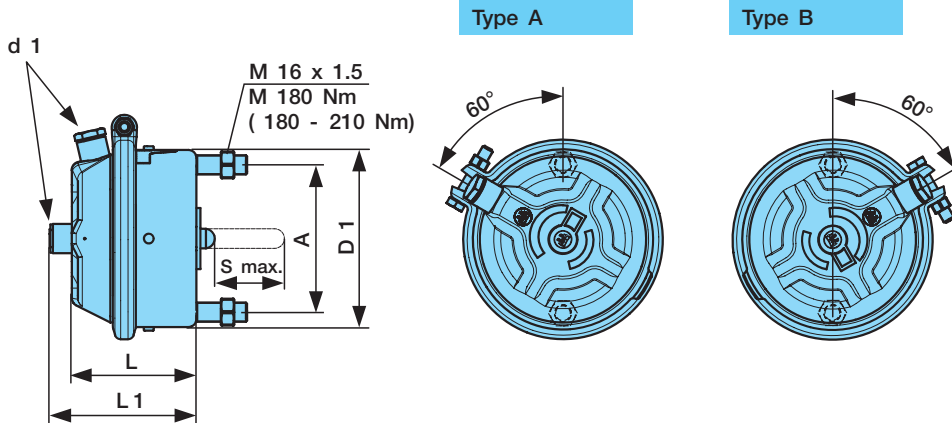

Brake cylinder size	BPW Code no.	Type	Air connection thread d 1	L (mm)	L 1 (mm)	D 1 (mm)	A (mm) Connection dimension	Piston stroke S max. (mm)			
14"	05.444.30.01.0	A	M 16 x 1.5	101	116	143	120.7	60			
	05.444.30.02.0	B									
15"	05.444.31.01.0	A						101	116	143	60
	05.444.31.02.0	B									
16"	05.444.32.01.0	A						101	116	145	60
	05.444.32.02.0	B									
18"	05.444.33.01.0	A						115	130	150	68
	05.444.33.02.0	B									
20"	05.444.34.01.0	A						115	130	150	68
	05.444.34.02.0	B									
22"	05.444.35.01.0	A						120	135	160	68
	05.444.35.02.0	B									
24"	05.444.36.01.0	A									68
	05.444.36.02.0	B									

Lock nuts for brake cylinder  
 Thread                      BPW Code no.  
 M 16 x 1.5                      02.5202.21.80

Diaphragm - diaphragm brake cylinder / Diaphragm - piston brake cylinder

Diaphragm - diaphragm  
brake cylinder  
( M - M )

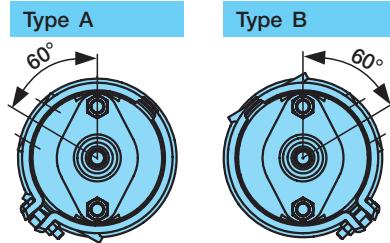

Diaphragm - piston  
brake cylinder  
( M - K )

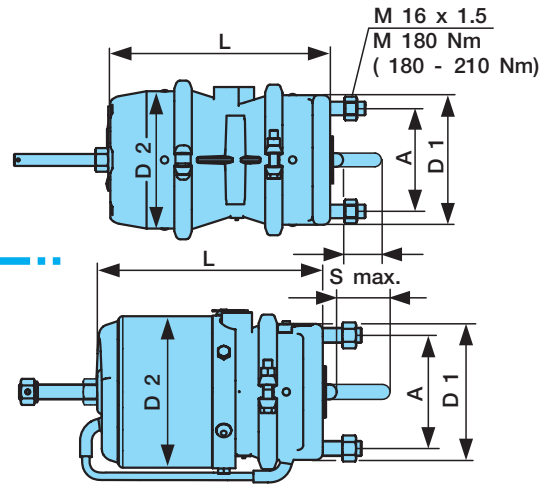
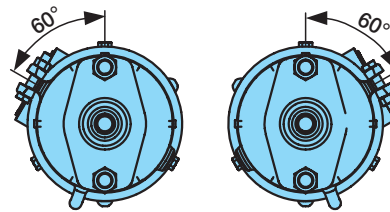

Brake cylinder size	BPW Code no. Brake cylinder without air connection fittings	Type	BPW Code no. Mounting kit with standard air connection fittings	BPW Code no. Brake cylinder with compressed air connection extension (DLAV)	Air connection thread	L (mm)	D 1 (mm)	D 2 (mm)	A (mm) Connection dimension	Piston stroke S max. (mm)
<b>Diaphragm - diaphragm brake cylinder ( M - M )</b>										
14 / 24"	05.444.38.01.0	A	05.801.09.77.0	05.444.38.01.3	M 16 x 1.5	232	145	162	120.7	57
	05.444.38.02.0	B		05.444.38.02.3						
15 / 24"	05.444.39.01.0	A	05.801.09.78.0	05.444.39.01.3						
	05.444.39.02.0	B		05.444.39.02.3						
16 / 24"	05.444.40.01.0	A	05.801.09.79.0	05.444.40.01.3						
	05.444.40.02.0	B		05.444.40.02.3						
18 / 24"	05.444.42.01.0	A	05.801.09.80.0	05.444.42.01.3						
	05.444.42.02.0	B		05.444.42.02.3						
20 / 24"	05.444.44.01.0	A	05.801.09.81.0	05.444.44.01.3						
	05.444.44.02.0	B		05.444.44.02.3						
<b>Diaphragm - piston brake cylinder ( M - K )</b>										
16 / 16"	05.444.41.01.0	A	05.801.21.38.0	05.444.41.01.3	M 16 x 1.5	255	145	162	120.7	60
	05.444.41.02.0	B		05.444.41.02.3						
20 / 24"	05.444.41.03.0 <sup>1)</sup>	A	05.801.21.39.0	05.444.41.03.3 <sup>1)</sup>						
	05.444.41.04.0 <sup>1)</sup>	B		05.444.41.04.3 <sup>1)</sup>						
	05.444.43.01.0	A		05.801.09.82.0		05.444.43.01.3				
	05.444.43.02.0	B				05.444.43.02.3				
22 / 24"	05.444.43.03.0 <sup>1)</sup>	A	05.801.09.97.0	05.444.43.03.3 <sup>1)</sup>						
	05.444.43.04.0 <sup>1)</sup>	B		05.444.43.04.3 <sup>1)</sup>						
	05.444.45.01.0	A		05.801.09.83.0	05.444.45.01.3					
	05.444.45.02.0	B			05.444.45.02.3					
24 / 24"	05.444.45.03.0 <sup>1)</sup>	A	05.801.09.98.0	05.444.45.03.3 <sup>1)</sup>						
	05.444.45.04.0 <sup>1)</sup>	B		05.444.45.04.3 <sup>1)</sup>						
	05.444.46.01.0	A		05.801.09.84.0	05.444.46.01.3					
	05.444.46.02.0	B			05.444.46.02.3					
24 / 24"	05.444.46.03.0 <sup>1)</sup>	A	05.801.09.99.0	05.444.46.03.3 <sup>1)</sup>						
	05.444.46.04.0 <sup>1)</sup>	B		05.444.46.04.3 <sup>1)</sup>						
<sup>1)</sup> for top trailing arm						<b>Lock nuts for brake cylinder</b> <b>Thread</b> <b>BPW Code no.</b> M 16 x 1.5                      02.5202.21.80				

### 3.8 BPW Brake Monitor

View

#### BPW Brake Monitor

With the BPW Brake Monitor retrofit kit for our disc brakes, you can check your vehicle from the outside at any time to see if the wear limit has been reached.

As soon as only one of the brake pads has worn down by approx. 80% the yellow "WARNING" LED on the BPW Brake Monitor starts flashing.

Once the minimum pad thickness of 2 mm has been reached, the "SERVICE" indicator changes to red, while the green and yellow LEDs flash alternately.

The red SERVICE indicator remains visible even if you have parked the vehicle and there is no electrical power supply to the trailer.

This means you can still tell if the wear limit has been reached on at least one brake pad. If this is the case, you should change the brake pads as soon as possible.



**Warning:**

At least one brake pad is approx. 80% worn down!

**Service:**

At least one brake pad as reached the minimum pad thickness of approx. 2 mm. Have the pads replaced immediately!

#### BPW Brake Monitor - Features and benefits

- Optimum use of the brake pad wear volume
- Longer service life for the brake discs and brake
- No unscheduled downtime
- No expensive follow-on costs (e.g. due to a complete failure)
- The service indicator tells you exactly when a brake pad needs changing, even if there is no operating voltage
- Operates without a separate ECU and does not need EBS
- Individual composition of kits possible because of modules (e.g. for four-axle vehicles)
- Quick and easy to install
- Can easily be retrofitted
- No technical inspection is required, since a general EU certification and hazchem approval have already been obtained
- Can be connected to EBS for indication in tractor vehicle

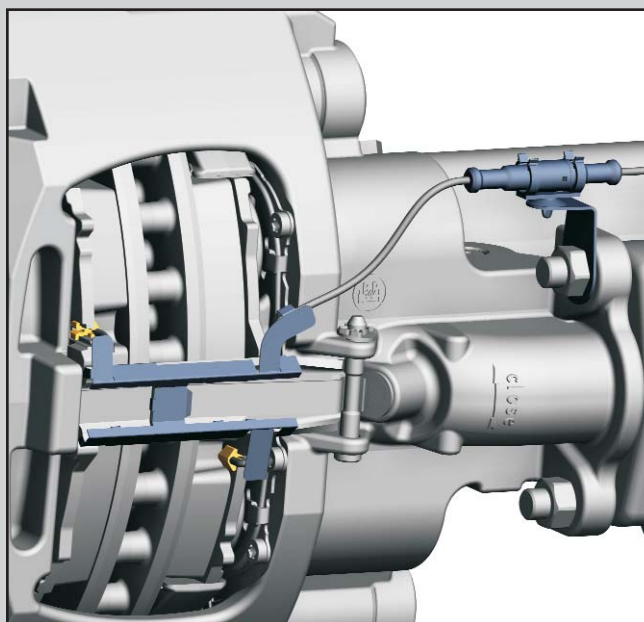



Component list for BPW brake lining wear indicator

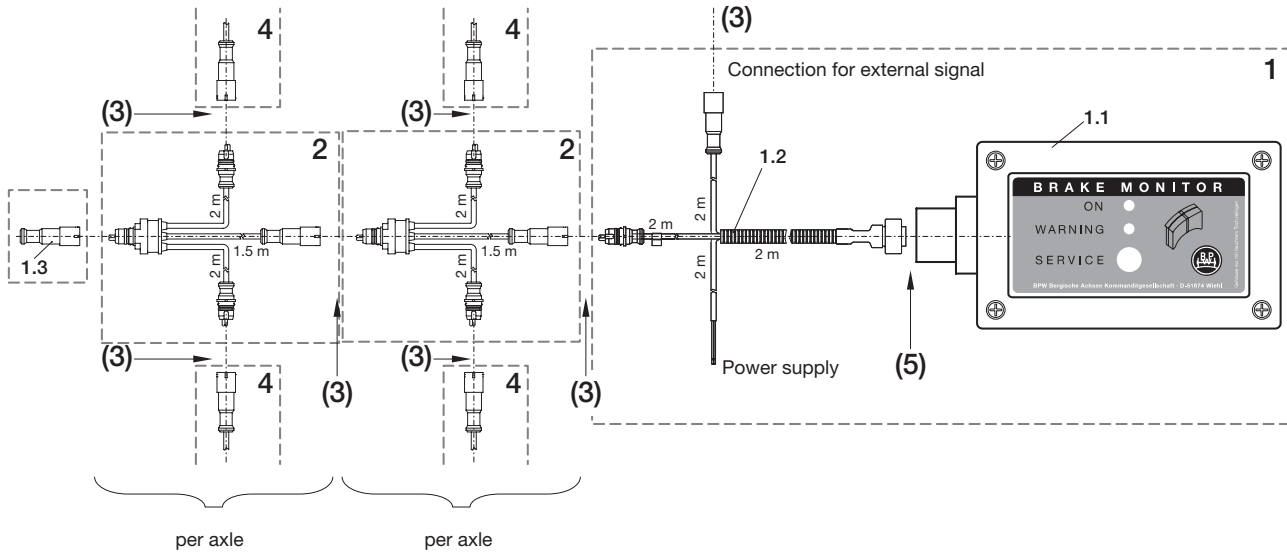

Vehicle Type

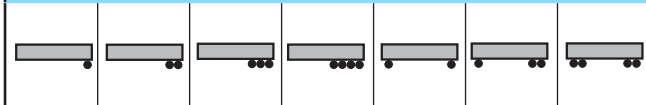

Item	BPW Code no.	Designation	Quantity						
			1-axle	2-axle	3-axle	4-axle	5-axle	6-axle	7-axle
1	05.801.50.38.0 incl. 1.1 02.0339.01.00 1.2 02.4312.58.00 1.3 02.3713.08.00	Basic set Brake Monitor Connecting cable Connecting plug	1 x	1 x	1 x	1 x	1 x	1 x	1 x
2	02.4312.57.00	Connection modul	1 x	2 x	3 x	4 x	2 x	3 x	4 x
3	Extension 3-pin K/E-connector system 02.1819.26.00 02.1819.25.00 02.1819.22.00	1 m 3 m 5 m	acc. to vehicle configuration						
4	05.801.50.49.0	Wear indicator axle set	1 x	2 x	3 x	4 x	2 x	3 x	4 x
5	Extension 7-pin DIN bayonet connector system 02.1819.29.00 02.1819.30.00	2 m 10 m	acc. to vehicle configuration						

4.1 Hub bearings, hub seals

View

General

BPW hub bearings

ECOPlus hub bearing

If you require long service life, rapid maintenance and low maintenance costs from your axle, there is only one option for you: ECOPlus.

Working on the basis of the special BPW ECO hub system, the ECO Unit has been further developed to create the trendsetting ECOPlus bearing system.

The maintenance-free hub has an integrated multi-seal system for protecting the tapered roller bearings against dust and dirt.

A central threaded connection with integrated torque limiting function ensures the bearing pre-load is always optimum.

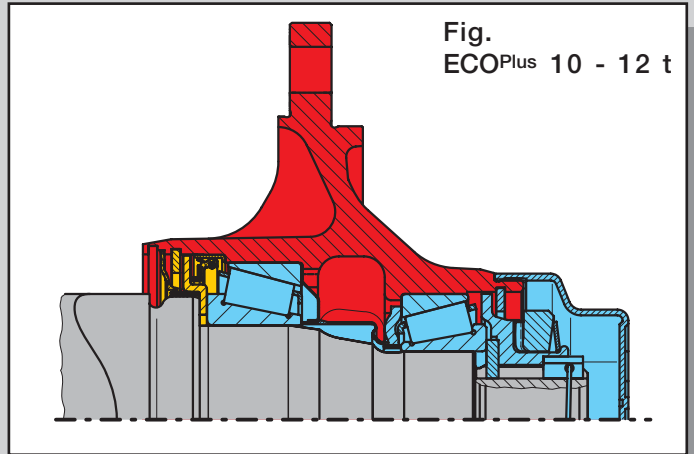

BPW ECOPlus bearing – Features and benefits

- Maintenance-free, encapsulated bearing unit (ECO Unit) with integrated multi-seal system to protect the taper roller bearings from dust and dirt.
- Integrated torque limiter in the axle nut (ECOPlus) / axle bolt (ECO Plus 2) prevents improper use when tightening
- Bearings are precisely re-adjusted after every disc replacement
- 5+3 years ECO Plus warranty (on-road) without mileage limit
- Compact bearing system with DIN-ISO taper roller bearings available worldwide for excellent availability and rapid service
- Removal of the complete hub unit - thanks to central threaded connection - with simple tools
- Excellent bearing service life with minimal life cycle costs

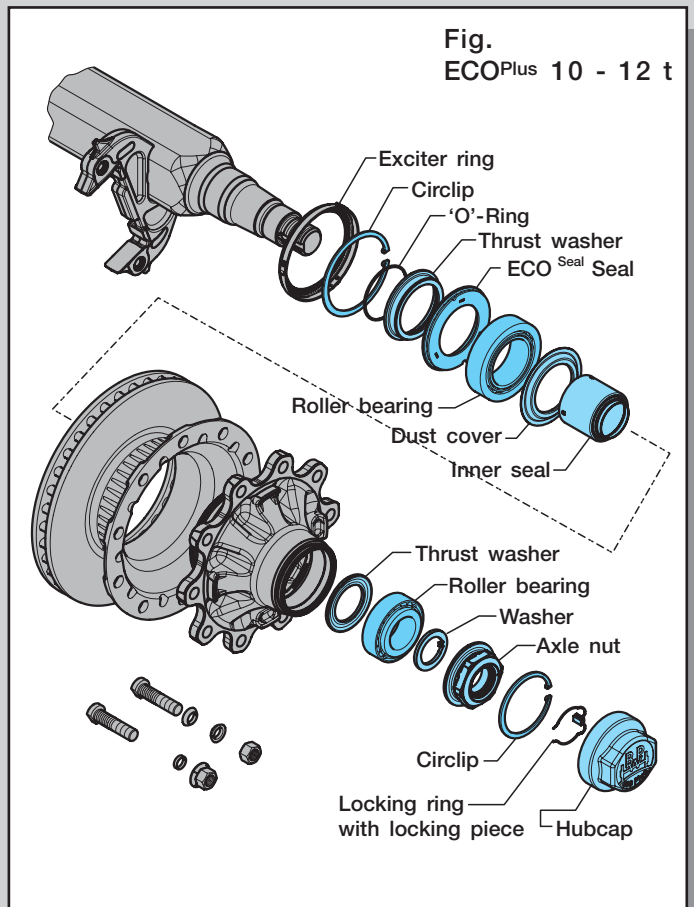

**ECO Plus 2 - the new generation of the tried and tested BPW ECO Unit**

The BPW ECO Unit, proven a million times over in its ECO<sup>Plus</sup> version, will be replaced from September 2007 by the still further improved, new **ECO Plus 2** design.

A rigorous upgrade of the components has resulted in a significant weight reduction compared with the current ECO<sup>Plus</sup> Unit.

In the case of the **ECO Plus 2** the hubcap has a bayonet fitting, enabling convenient fitting and removal of the cap.

Grease is supplied to the wheel bearings by means of a grease cartridge located between the bearings.

The axle nut previously used is replaced by an axle bolt with integrated torque limiter.

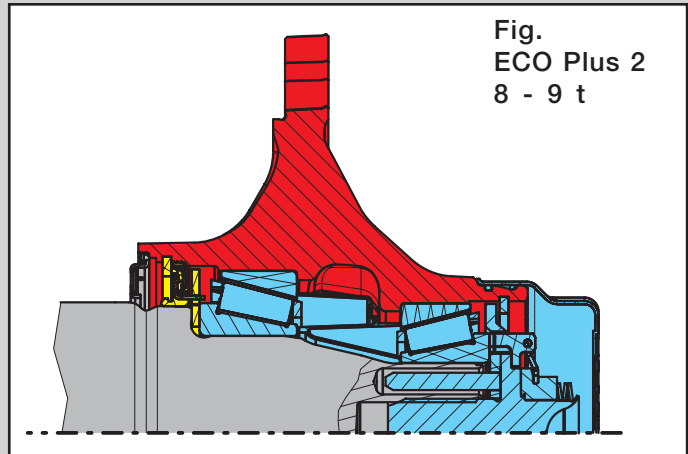

Fig.  
ECO Plus 2  
8 - 9 t

**ECO Plus 2 bearing - Features and benefits**

- Maintenance-free, encapsulated bearing unit (ECO Unit) with integrated multi-seal system to protect the taper roller bearings from dust and dirt
- Axle bolt with torque limiter prevents improper use when tightening
- Bearings are precisely re-adjusted after every disc replacement
- 5+3 years ECO Plus warranty (on-road) without mileage limit
- Compact bearing system with DIN-ISO taper roller bearings available worldwide for excellent availability and rapid service
- Removal of the complete hub unit - thanks to central threaded connection - with simple tools
- Simple greasing of the bearing by means of a grease cartridge
- Excellent bearing service life with minimal life cycle costs
- In conjunction with the revised air suspension system there are weight-savings of up to 25 kg, depending on the axle model
- Existing approvals and homologations remain in force

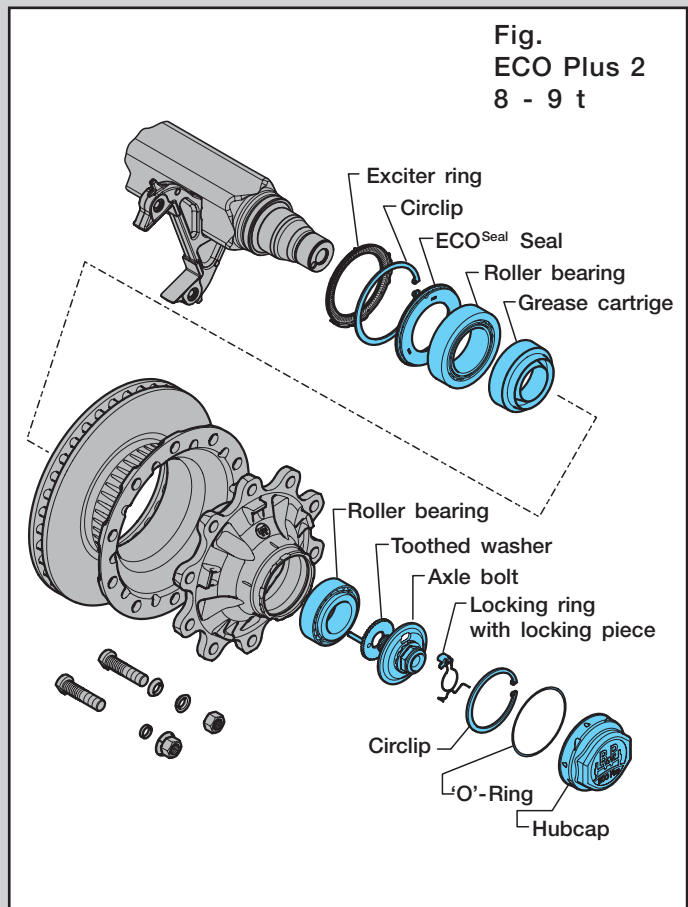

Fig.  
ECO Plus 2  
8 - 9 t

## 4.1 Hub bearings, hub seals

View

### ECO Plus 2 Hubcap / ECOMETER

BPW trailer axles with the ECO Plus 2 Unit have hubcaps (and ECOMETERS) with a bayonet fitting.

The bayonet fitting replaces the previously usual threaded connection.

A 120 mm installation spanner (BPW part number 03.339.05.02.0, see also BPW tool catalogue) is needed for fitting or removing the new hubcaps with the bayonet fitting.

 **An impact driver must not be used for fitting / removing hubcaps or ECOMETERS with a bayonet fitting!**

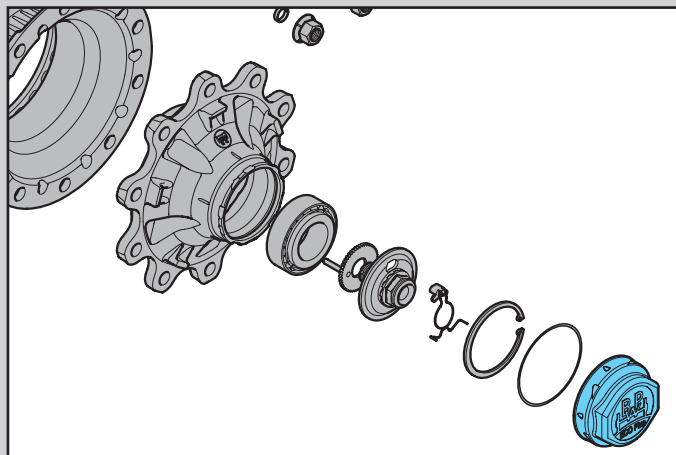

### Removal

To remove the hubcap it is turned anticlockwise through approx. 30 degrees with the installation spanner (Fig.).

When turned further, the hubcap lifts clearly away from the hub seat.

The released position is also indicated by markings on the hubcap and on the wheel hub (Fig. / Arrows).

In the released position the hubcap can be removed from the wheel hub by pulling it away.

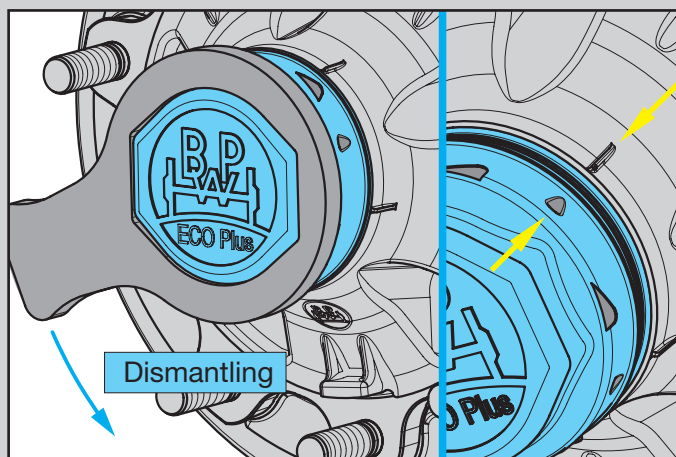

### Assembly

The seal between the hubcap and the wheel hub takes the form of an 'O'-ring in the case of the ECO Plus 2 Unit.

The 'O'-ring is inserted in the groove on the hub collar of the wheel hub, and **is to be replaced every time**. The hubcap itself is to be given a thin coating of **BPW ECO-LiPlus special long-life grease** inside in the area of the bayonet fitting, before assembly.

Corresponding markings in the hubcap and on the hub make it easier to fit the hubcap.

The figure shows the hubcap in the correct position for fitting, with the spanner engaged.

After been placed in position, the hubcap is pressed onto the hub and at the same time turned in clockwise direction.

The hubcap is firmly in place when the position shown in Fig. (arrows) has been reached.

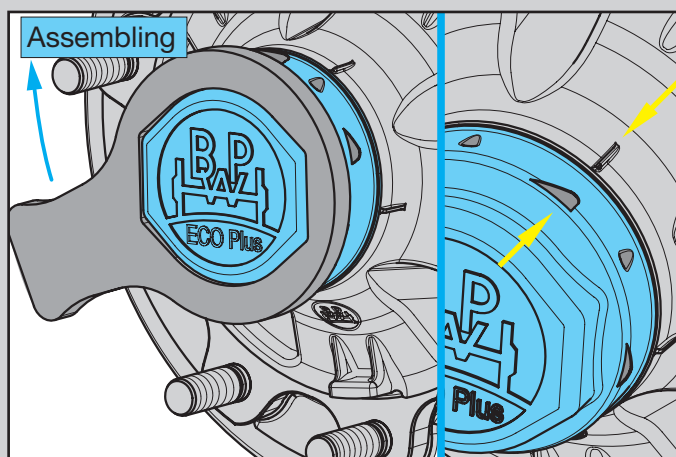

**Hub seal for ECOPlus bearings**

The innovative ECOSeal sealing system is used on all axles with the BPW ECO Disc Trailer disc brake.

With this hub seal, the primary seal lip (ECOSeal) no longer seals directly against the race of the hub but instead against a race which is integrated in the seal itself.

This new design enables the circumferential velocity of the seal to be significantly reduced, and with that, the amount of wear. In addition, the wheel bearing is provided with even better protection against dirt penetration by means of the covering dust and dirt sealing lips.

**Benefits:**

- An introversive pre-stressed main seal lip with a low circumferential speed and a low thermal load, resulting in low wear
- An approximately 30% reduction in frictional resistance inside the seal (compared with conventional seals)
- The seal is well protected during service due to the cartridge construction
- Pre-stressed main seal lip with ventilation function, no opening at low pressures
- No coarse dirt seal required

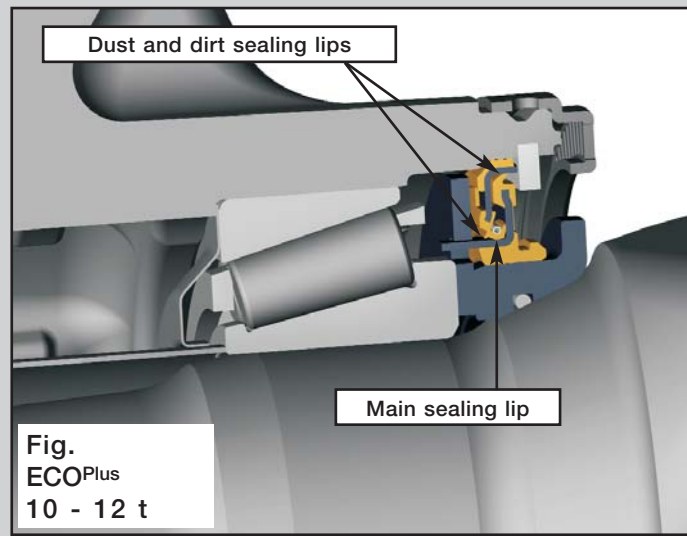
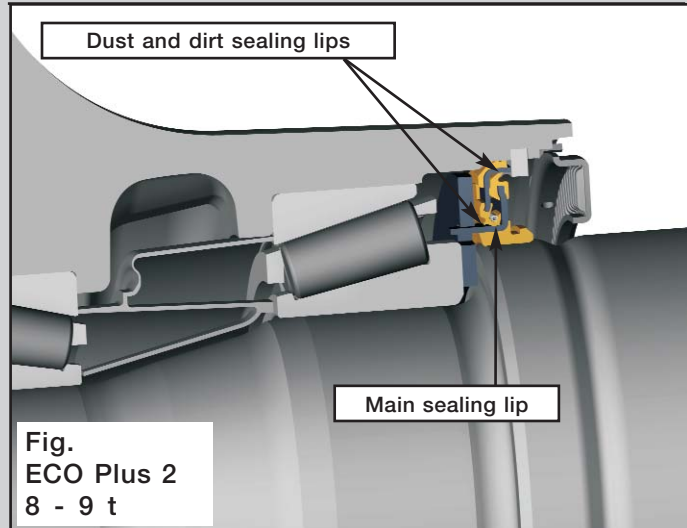

4.2 Hub bearings, hub seals

ECO Plus 2 bearing

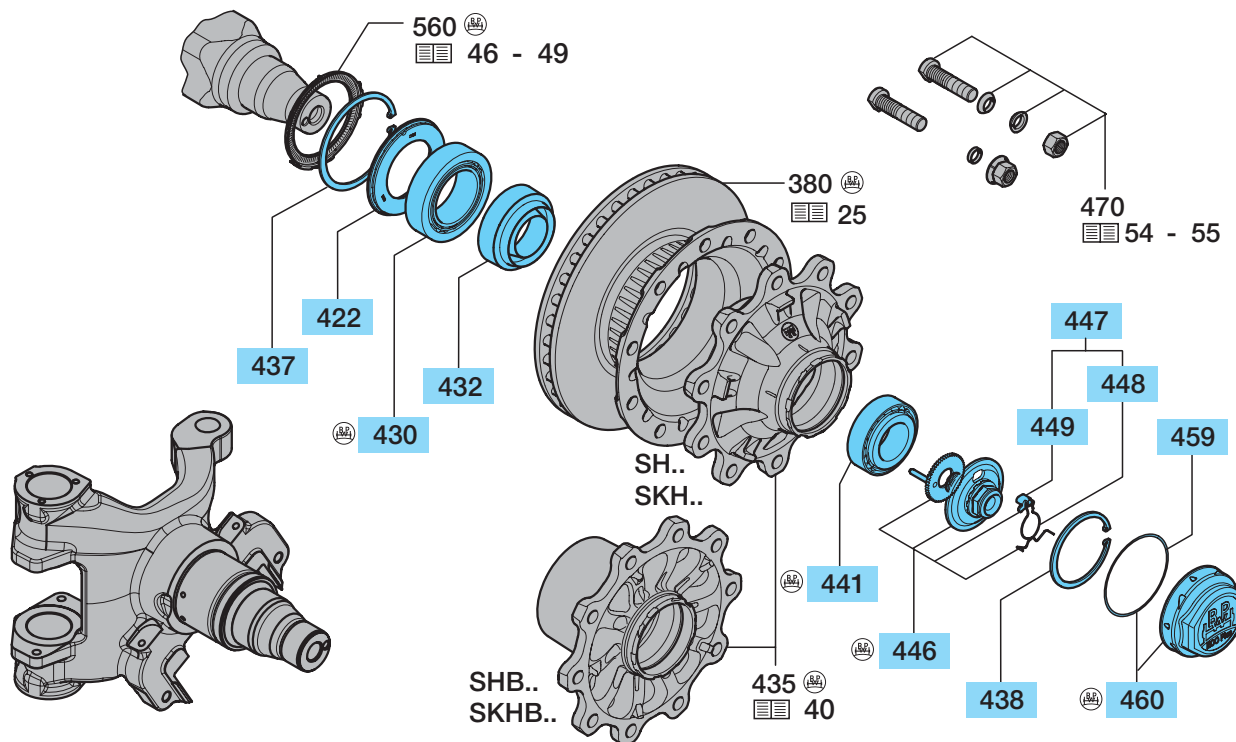

Item	Designation (Remark)	BPW Code no.	Dimension
		<b>SH.. ECO Plus 2</b> <b>SKH.. ECO Plus 2</b> <b>8 - 9 t</b>	<b>--.58.---.---</b>
380	Brake disc	see page 25	
416	Repair kit roller bearing <b>with</b> axle bolt and hubcap (item 422, 430, 432, 437 - 460)	<b>09.801.07.33.0</b>	for 1 axle side
419	Repair kit roller bearing <b>without</b> axle bolt and hubcap (item 422, 430, 437, 438, 441, 459)	<b>09.801.07.34.0</b>	for 1 axle side
422	ECOSeal seal	02.5664.74.00	Ø 117.5 x 158 x 17.5
430	Roller bearing	02.6410.23.00	33118
432	Grease cartridge	03.120.47.08.0	Ø 101 / 130 x 50
435	Hub	see page 40	
437	Circlip	02.5606.58.90	158 x 4 / 472
438	Circlip	02.5606.22.90	122 x 4 / 472
441	Roller bearing	02.6410.22.00	33213
446	Axle bolt with toothed washer (incl. item 447)	09.001.37.03.0	M 32 x 2 / SW 46
447	Locking ring cpl. (item 448 + 449)	05.188.03.10.0	
448	Locking ring	03.188.03.09.0	
449	Locking piece	03.277.10.01.0	
459	'O'-Ring	02.5678.65.00	Ø 128 x 3
460	Hubcap (Bayonet) (incl. item 459)	05.212.25.78.0	Ø 137 / 142 x 56 / SW 120

## ECOPlus bearing

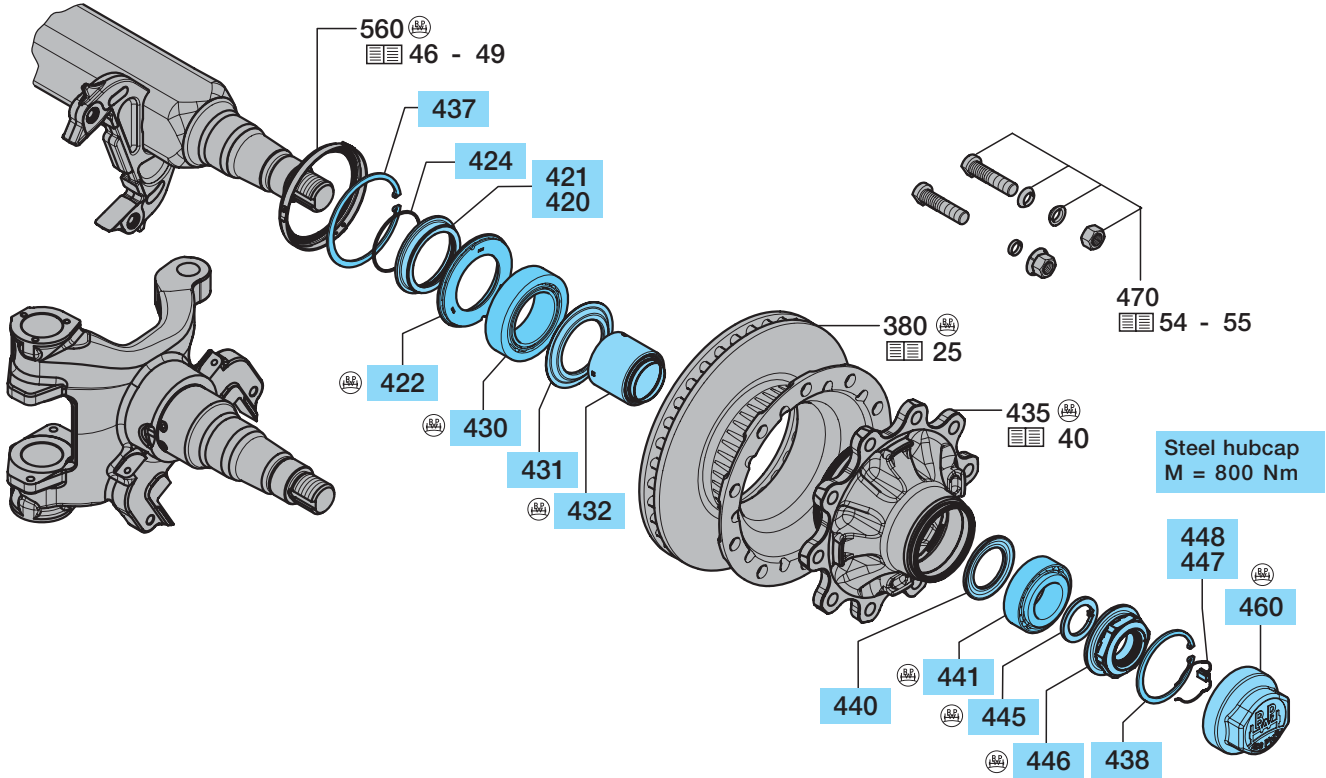

Item	Designation (Remark)	BPW Code no.	Dimension
		<b>SH.. / SKH.. ECOPlus</b>	
		<b>10 - 12 t</b>	
		<b>---50,---,---</b>	
380	Brake disc	see page 25	
418	Repair kit roller bearing <b>without</b> axle nut and hubcap (item 420, 423, 428, 430, 431, 432, 440 - 445)	<b>09.801.07.04.0</b>	for 1 axle side
420	Thrust washer cpl. (item 421, 424)	05.370.07.73.0	
421	Thrust washer	03.370.07.72.0	Ø 96 / 117.5 / 132 x 22
422	ECOSeal seal	02.5664.74.00	Ø 117.5 x 158 x 17.5
424	'O'-Ring	02.5678.00.00	Ø 100 x 3
430	Roller bearing	02.6410.23.00	33118
431	Dust cover	03.010.93.34.0	Ø 94 / 149 x 8.5
432	Seal	03.120.45.16.0	Ø 67 / 93 x 90.5
435	Hub	see page 40	
437	Circlip	02.5606.58.90	158 x 4 / 472
438	Circlip	02.5606.22.90	122 x 4 / 472
440	Thrust washer	03.370.26.24.0	Ø 71 / 108 x 8
441	Roller bearing	02.6410.22.00	33213
445	Washer	03.320.64.01.0	Ø 53 / 76 x 5.8
446	Axle nut	05.266.47.06.0	M 52 x 2 / SW 95
447	Locking piece	03.277.00.07.0	
448	Locking ring	03.188.04.10.0	
460	Hubcap	03.212.25.31.0	M 136 x 2.5 / SW 110

## 4.4 Hubs

SKH..(LL) ECO Plus 2 (TSB 3709)						
		Hubcap thread	8 - 9 t --.58.---,---		Complete hub BPW Code no.	
435	Hub					
	220,8 / 275 / 8 x Ø 22					
	SKH.. ECO Plus 2	Steel and alloy wheels	Bayonet lock	03.272.46.33.0		09.801.07.36.0
	SKMZ..LL ECO Plus 2	Steel wheels				
	SKHZMLL ECO Plus 2	Alloy wheels				
	280,8 / 335 / 10 x Ø 22					
	SKH.. ECO Plus 2	Steel and alloy wheels	Bayonet lock	03.272.43.29.0		09.801.07.35.0
	SKMS..LL ECO Plus 2	Steel wheels				
	SKHB.. ECO Plus 2	Steel and alloy wheels				
				03.272.43.28.0		09.801.07.32.0

SH..(LL) ECO Plus 2 (TSB 4309 / 4312)						
		Hubcap thread	8 - 9 t --.58.---,---		Complete hub BPW Code no.	
435	Hub					
	280,8 / 335 / 10 x Ø 22					
	SH.. ECO Plus 2	Steel and alloy wheels	Bayonet lock	03.272.43.29.0		09.801.07.35.0
	SHS..LL ECO Plus 2	Steel and alloy wheels				
	SMS..LL ECO Plus 2	Steel wheels				
	SMZ..LL ECO Plus 2	Steel wheels				
	SHB.. ECO Plus 2	Steel and alloy wheels	Bayonet lock	03.272.43.28.0		09.801.07.32.0
	SHB..LL ECO Plus 2	Steel and alloy wheels				
	SMB..LL ECO Plus 2	Steel wheels				

SKH..(LL) ECOPlus (TSB 3709)						
		Hubcap thread		10 - 12 t --.50.---,---	Complete hub BPW Code no.	
435	Hub					
	220,8 / 275 / 8 x Ø 22					
	SKH.. ECOPlus	Steel and alloy wheels	M 136 x 2.5		03.272.46.30.2	09.801.06.59.2
	280,8 / 335 / 10 x Ø 22					
	SKH.. ECOPlus	Steel and alloy wheels	M 136 x 2.5		03.272.43.24.2	09.801.06.22.0
	SKHZM.. ECOPlus	Alloy wheels	M 136 x 2.5		03.272.43.18.0	-

SH..(LL) ECOPlus (TSB 4309 / 4312)						
		Hubcap thread		10 - 12 t --.50.---,---	Complete hub BPW Code no.	
435	Hub					
	280,8 / 335 / 10 x Ø 22					
	SH.. ECOPlus	Steel and alloy wheels	M 136 x 2.5		03.272.43.22.2	09.801.06.62.2
	SHZM.. ECOPlus	Alloy wheels	M 136 x 2.5		03.272.43.26.2	09.801.06.23.2



## Grease sprays for greasing taper roller bearings 4.5

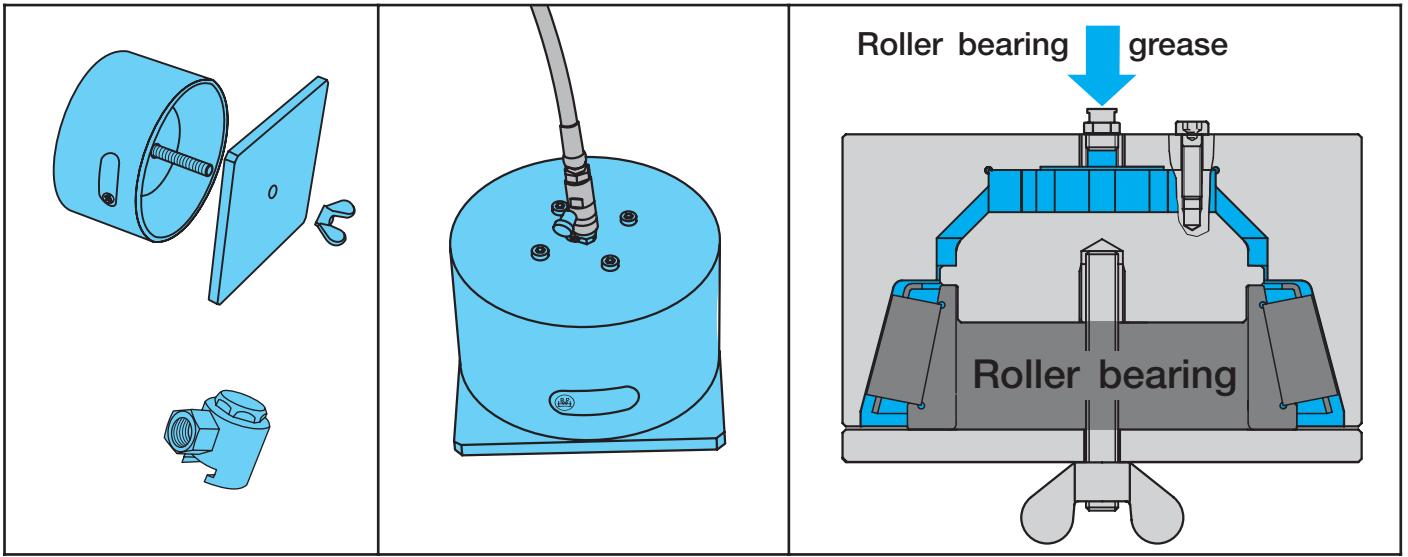

Grease spray	for taper roller bearing	BPW Code no. grease spray loose	BPW Code no. complete set
	33118	16.062.22935	99.00.000.9.55
	33213	16.068.22935	
Complete set including adapter for flat grease nipple			
Adapter for flat grease nipple			BPW Code no.
			15.069.22935

4.6 Grease filling, bearing adjustment

ECO Plus 2 bearing

Grease filling per wheel hub

Fig. ECO Plus 2, 8 - 9 t

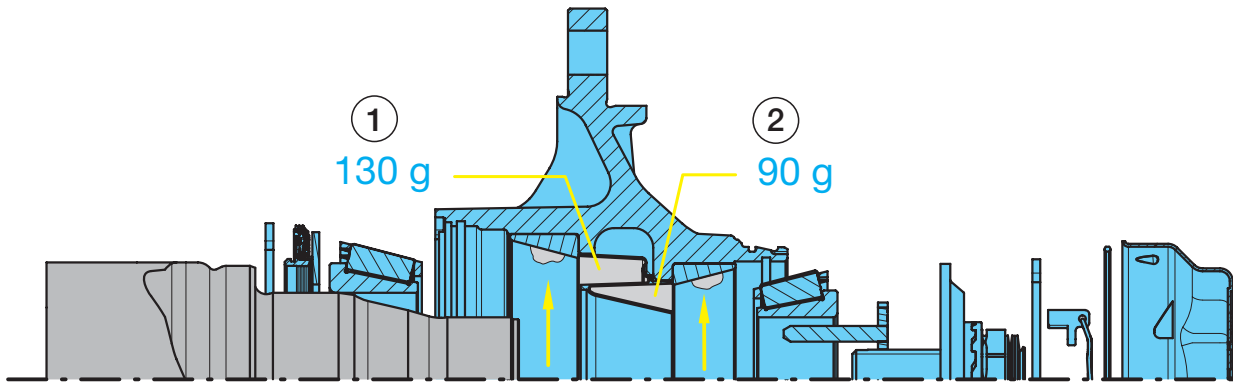

The ECO Plus 2 hub system is designed for the use of longlife grease. On expiry of the guarantee, the roller bearings, the inside of the hub and the seals are to be thoroughly cleaned (with diesel oil), dried, checked to see if they can be re-used; and re-greased every three years when used off-road, or every 5 years when used on the road, within Europe (or every year when off-road and every two years when on the road outside of Europe) (observe the current BPW maintenance instructions). Spray the stub-axle bearing seats with **BPW ECO Assembly and Protection Spray** (BPW no. 02.3521.12.00).

		BPW longlife roller bearing grease ECO-Li <sup>Plus</sup> , quantity per tapered roller bearing			
		① inner		② outer	
Axle load	Axle type	Roller bearing	Quantity	Roller bearing	Quantity
8000 - 9000 kg	SH.. 8 - 9 t ECO Plus 2 SK.. 8 - 9 t ECO Plus 2	33118	130 g	33213	90 g

Clean the grease cartridge and fill it on both sides up to the edge with **BPW ECO-Li<sup>Plus</sup> special long-life grease**.  
 ① and ② Apply a ring-shaped bead of grease to the running surfaces of the outer bearing races.  
 Apply a coat of **BPW ECO-Li<sup>Plus</sup> special long-life grease** all around the lip of the seal.

For other procedures see the current maintenance instructions.

When BPW grease applicators are used there is no need to fill the grease cartridge or to apply the bead of grease.  
 Greasing with grease cartridge see page 41.

**Bearing adjustment**

1. Undo the hubcap by turning it through approx. 30 degrees in an anticlockwise direction (see page 36). When turned further the hubcap lifts clearly away from the ECO unit and can be removed by pulling it away.
2. Remove the hooked spring ring and retaining key from the axle bolt.
3. Tighten the axle bolt while at the same time turning the ECO unit with a 46 mm hexagon spanner until the crown of the axle bolt clicks round.  
**NB! Do not use an impact driver.**
4. Insert the retaining key into the recess in the axle bolt and into the crown of the toothed lock washer (do not turn the axle bolt back).
5. Insert the hooked spring ring into the groove at the end of the hexagon profile of the axle bolt.
6. Insert a new 'O'-ring into the groove in the wheel hub.
7. Apply a thin layer of **BPW ECOLI<sup>Plus</sup> special long-life grease** to the hubcap in the area of the bayonet fitting.
8. Put the hubcap on (position 1, page 36). Use the 120 mm hubcap spanner to lock the hubcap in place by turning it through approx. 30 degrees in a clockwise direction, while at the same time pressing on the hubcap. It is firmly in place when it reaches position 2 (page 36).

**NB! Do not use an impact driver - bayonet fitting.**

**ECOPlus bearing**

**Grease filling per wheel hub**

Fig. ECOPlus, 10 - 12 t

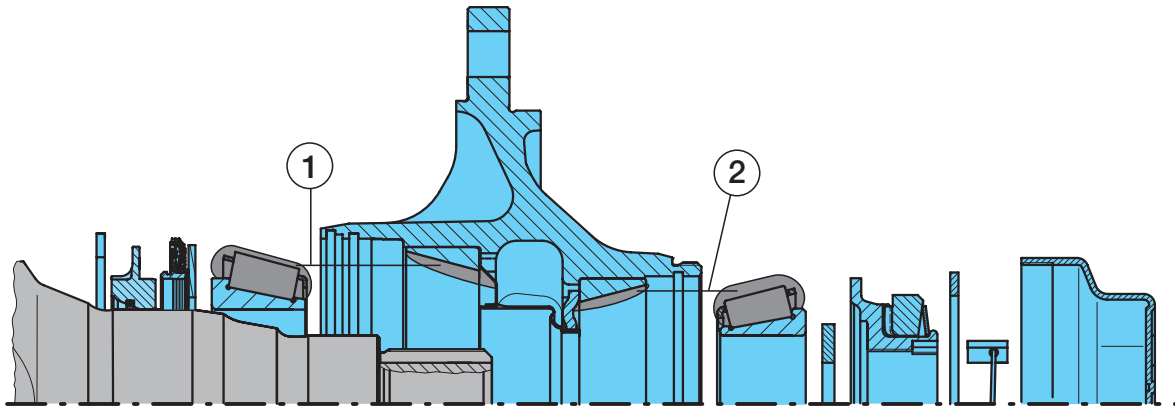

The ECOPlus hub system is designed for the use of longlife grease. On expiry of the guarantee, the roller bearings, the inside of the hub and the seals are to be thoroughly cleaned (with diesel oil), dried, checked to see if they can be re-used; and re-greased every three years when used off-road, or every 5 years when used on the road, within Europe (or every year when off-road and every two years when on the road outside of Europe) (observe the current BPW maintenance instructions).  
Spray the stub-axle bearing seats with **BPW ECO Assembly and Protection Spray** (BPW no. 02.3521.12.00).

		BPW longlife roller bearing grease ECO-LiPlus, quantity per tapered roller bearing			
		① inner		② outer	
Axle load	Axle type	Roller bearing	Quantity	Roller bearing	Quantity
10000 - 12000 kg	SH.. 10 - 12 t ECOPlus SK.. 10 - 12 t ECOPlus	33118	170 g 130 g *	33213	120 g 90 g *

**Work BPW longlife roller bearing grease ECO-LiPlus** thoroughly into the spaces between the tapered rollers and the races. Apply remainder to outer races in the hub.  
Renew the lip seal and smear contact area with **BPW longlife roller bearing grease ECO-LiPlus**.  
For other procedures see the current maintenance instructions.

\* Greasing with grease cartridge see page 41.

**Bearing adjustment**

1. Unscrew the hubcap.
2. Remove the hooked spring ring and retaining key from the axle nut.
3. Use a spanner to tighten the axle nut whilst at the same time turning the wheel hub, until the axle nut torque limiter operates (do not use an impact driver).
4. Fit the retaining key in the groove between the axle stub and the nut (do not reset the axle nut).
5. Insert the hooked spring ring, depending on the version, behind the flange on the axle nut or in the thread on the axle stub.
6. Screw on hubcap and tighten to 800 Nm.

BPW longlife roller bearing grease ECO-LiPlus	Container	BPW Code no.
	0.4 kg Cartridge	02.1040.45.00
	5 kg Bucket	02.1040.47.00
	25 kg Bucket	02.1040.49.00
	50 kg Drum	02.1040.50.00

5.1 ABS

View

General

ABS

In the anti-lock brake system (ABS), the wheel movement is recorded using a proximity-type arrangement with an exciter ring attached to the hub and a sensor (speed sensor) that generates the pulses.

As a result, the wheel speed of each wheel is continuously sent to the central control ECU. This runs a complex programme for processing the received information about the movement of the wheel as well as for calculating and performing logical operations on the control signals. Using the pressure control valves assigned to each wheel, it adjusts the air pressure and therefore the braking of each individual wheel (depending on the ABS system).

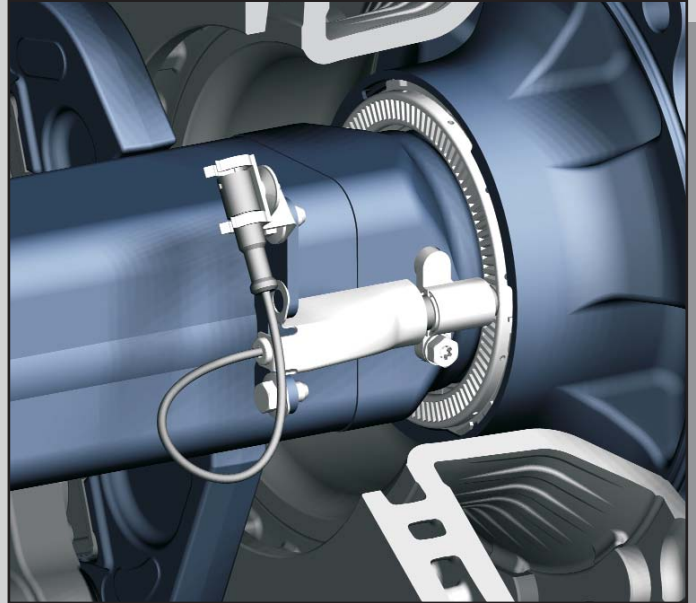

Almost all BPW axles can be retrofitted with ABS without problems. To do this, simply take the exciter ring, sensor brackets, sensors and fastening parts contained in the retrofit kit and attach them to the axle in accordance with the supplied installation drawing, then connect them to the vehicle electronic system.

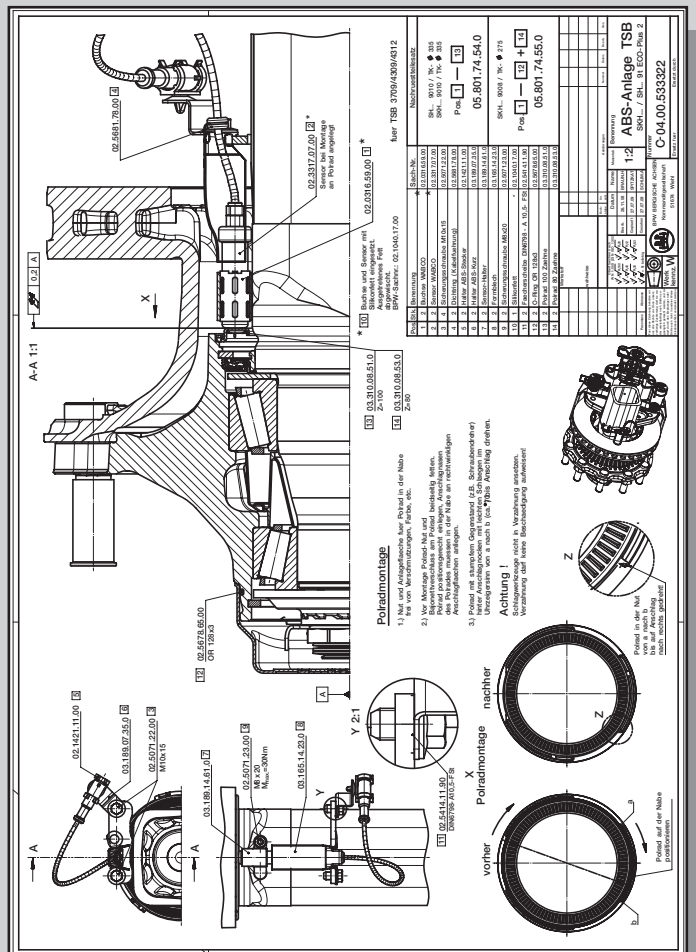

**Attachments of the sensor brackets**

Various sensor attachments are used, depending on the axle design.

- Sensor attachment on the brake body or the axle beam (lug), without any additional components
  
- Bolted sensor attachment on the axle beam / steering axle stub

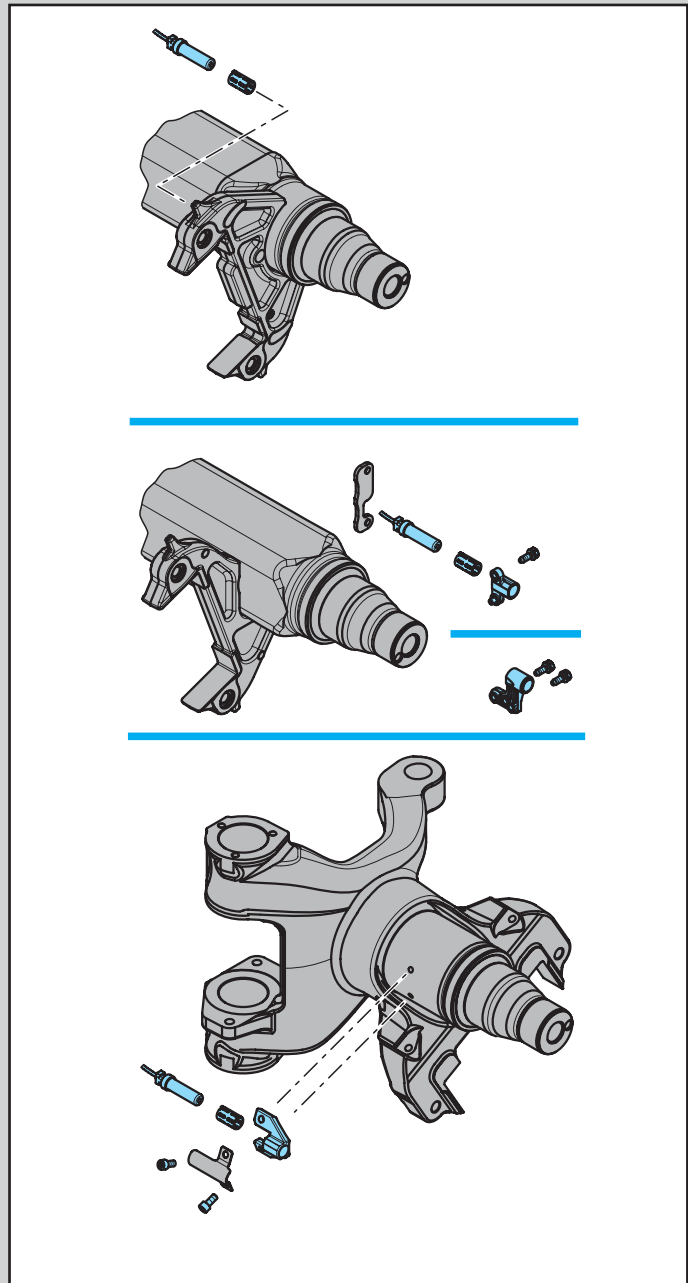

5.2 ABS

ABS parts / TSB 3709 / 4309 / 4312 - Rigid axles

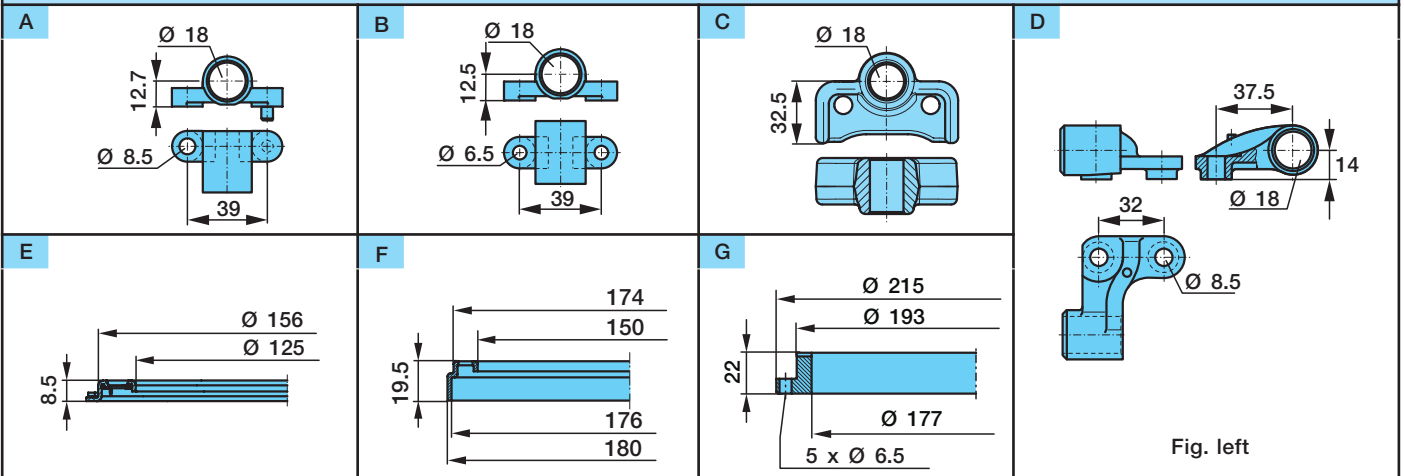

ECO Plus 2

ECOPlus

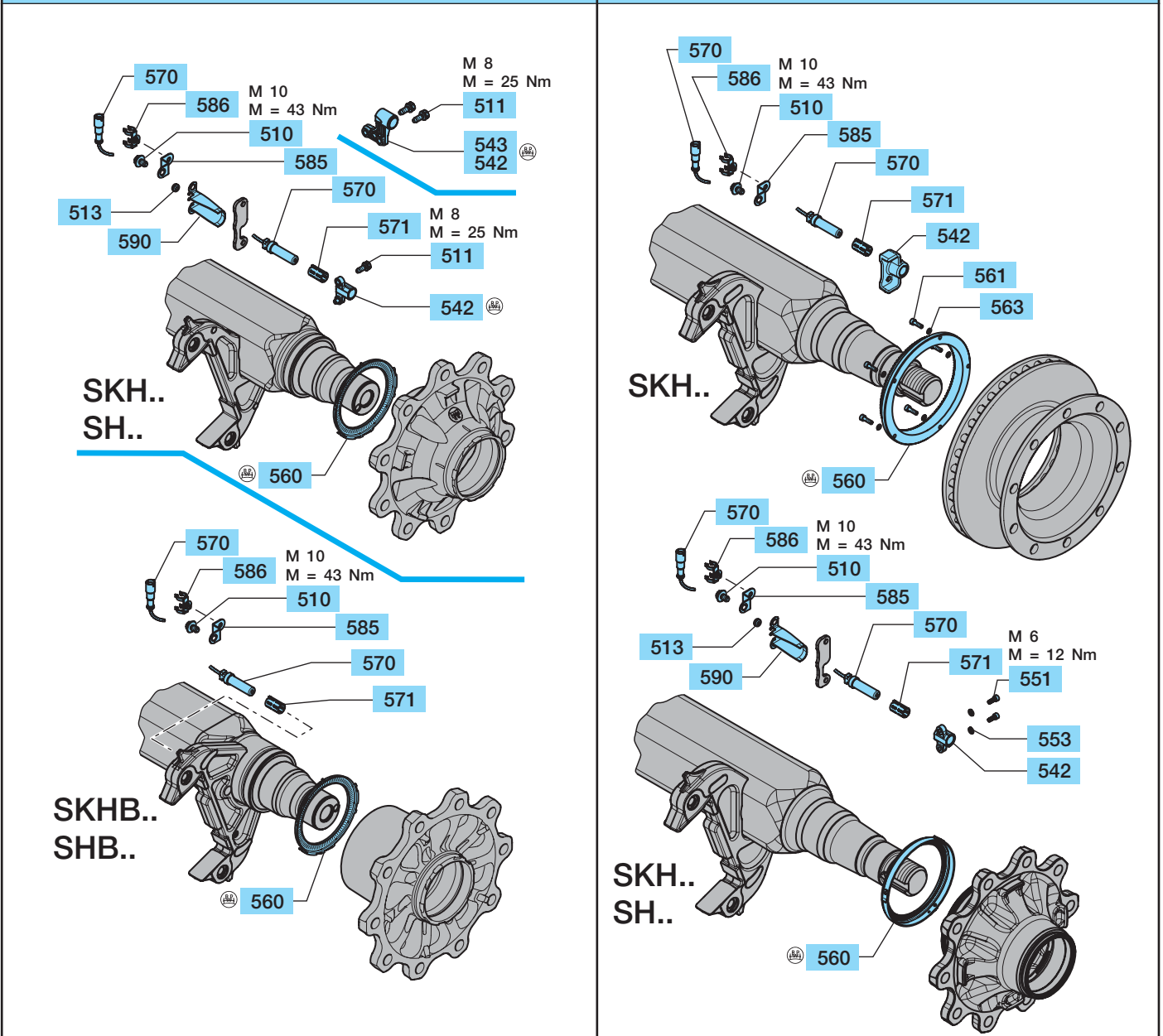

**ABS parts / TSB 3709 / 4309 / 4312 - Rigid axles**

Item	Designation	Dimension	Fig.	BPW Code no.	TSB 3709				TSB 4309			TSB 4312		
					SKHB.. 8010 / 9010 ECO Plus 2	SKHS.. 8008 / 9008 ECO Plus 2	SKHZ.. 8008 / 9008 ECO Plus 2	SKHS.. 8010 / 9010 ECO Plus 2	SKHZ.. 8010 / 9010 ECO Plus 2	SKH.. 10008 ECOPlus	SKH.. 10010 ECOPlus	SHB.. 8010 / 9010 ECO Plus 2	SHS.. 8010 / 9010 ECO Plus 2	SHZ.. 8010 / 9010 ECO Plus 2
510	Locking bolt	M 10 x 15		02.5071.22.00		●	●				●	●		
511	Locking bolt	M 8 x 20		02.5071.23.00		●	●				●	●		
513	Cable protection			02.5681.78.00			●				●	●		
542	Sensor bracket		A	03.189.14.61.0		●	●				●			
			B	03.189.07.87.0										●
			C	03.189.15.76.0					●	●				
542	Sensor bracket, right		D	03.189.07.58.0								●		
543	Sensor bracket, left			03.189.07.59.0										
551	Cylinder head bolt	M 6 x 16		02.5015.00.80									●	
553	Spring washer	A 6		02.5601.06.90									●	
560	Exciter ring	Ø 125 / 156 x 8,5 / Z = 100	E	03.310.08.51.0	●		●			●	●			
		Ø 125 / 156 x 8,5 / Z = 80		03.310.08.53.0		●								
		Ø 150 / 174 / 176 / 180 x 19,5 / Z = 100	F	05.310.08.50.1									●	●
		Ø 177 / 193 / 215 x 14/22 Z = 80	G	03.310.09.38.0				●						
		Ø 177 / 193 / 215 x 14/22 Z = 100		03.310.09.39.0					●					
561	Cylinder head bolt	M 6 x 30 - 8.8		02.5015.48.82									●	
		M 6 x 20 - 8.8		02.5015.06.82								●		
563	Spring washer	Ø 6		02.5611.06.90							●	●		
570	Sensor, straight	L = 350		02.3317.07.00	●	●	●			●	●	●	●	
	Sensor, cranked			02.3317.05.00					●	●				
571	Bush			02.0316.59.00	●	●	●	●	●	●	●	●	●	
585	Support	short - L 35		03.189.07.35.0	●	●	●	●	●	●	●	●	●	
586	Support			02.1421.11.00	●	●	●	●	●	●	●	●	●	
590	Heat protection plate			03.165.14.23.0		●	●				●	●	●	
	Special silicone grease	3 g		02.1040.17.00	●	●	●	●	●	●	●	●	●	

5.3 ABS

ABS parts / TSB 3709 / 4309 - Steering axles

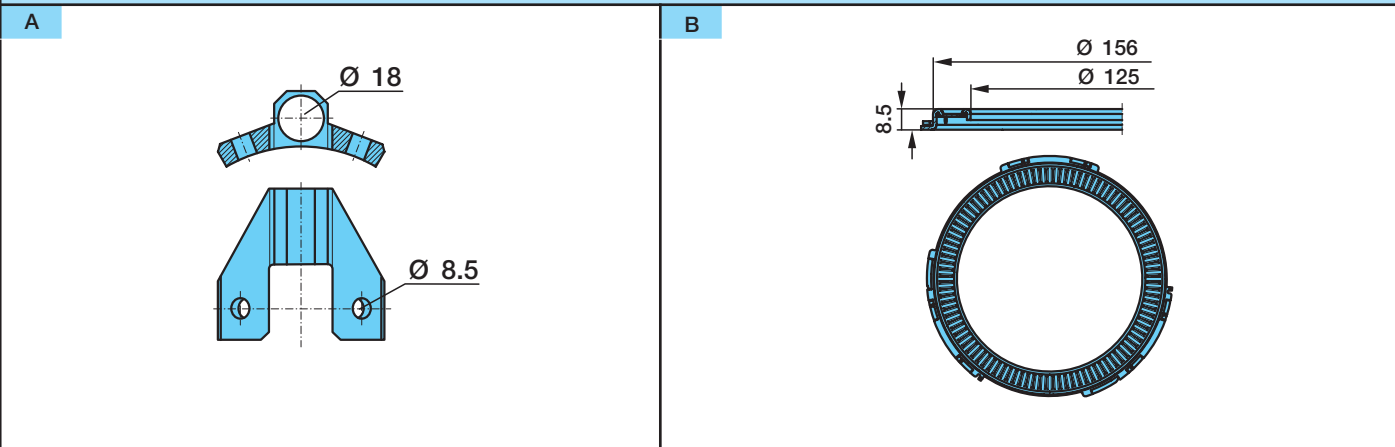

BPW ECO Disc TSB 3709 / 4309

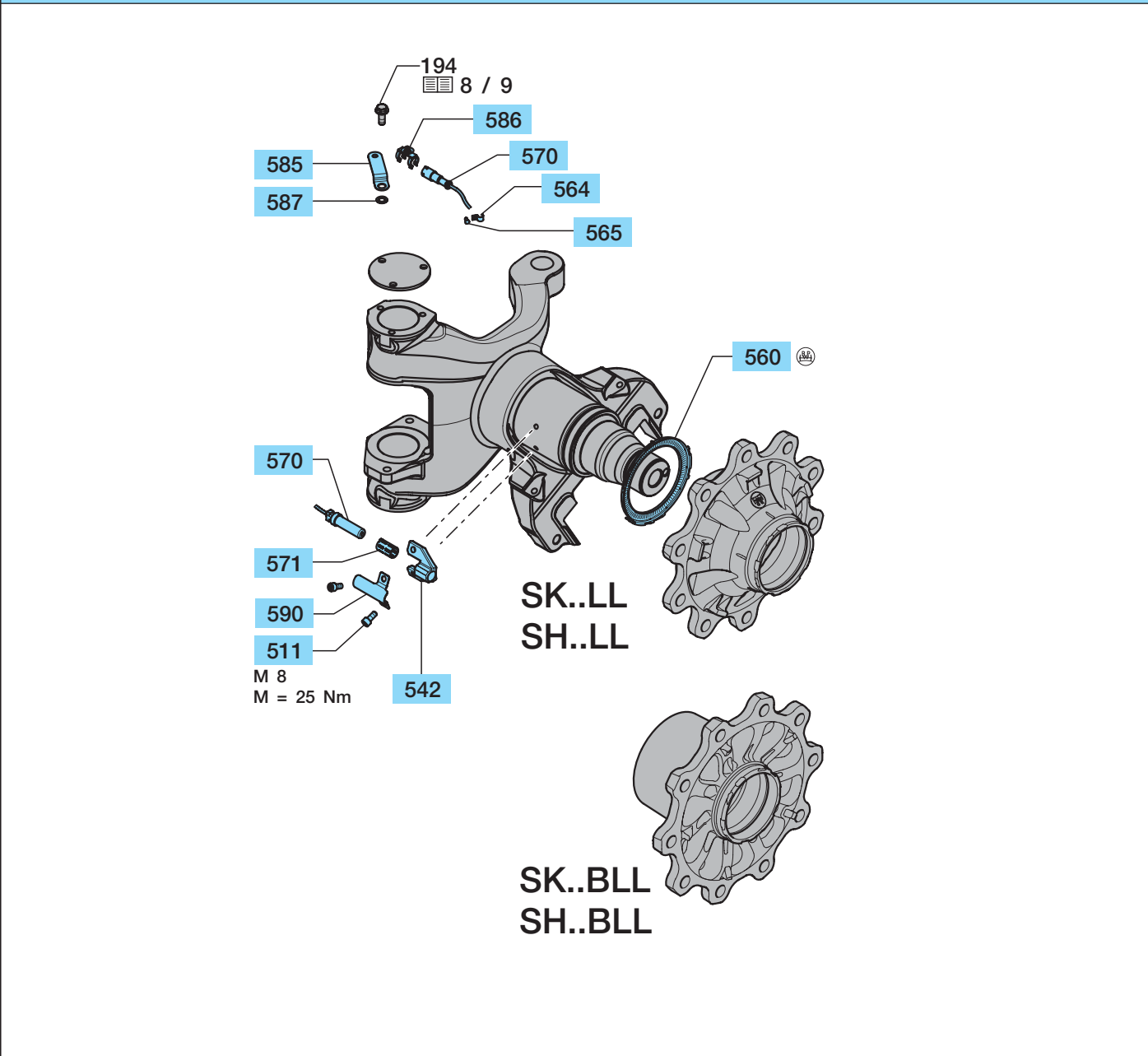



**ABS parts / TSB 3709 / 4309 - Steering axles**

Item	Designation	Dimension	Fig	BPW Code no.	TSB 3709		TSB 4309	
					SK..B..LL 7510 - 9010	SK..S..LL 8008 / 9008 SK..Z..LL 8008 / 9008	SK..S..LL 8010 / 9010 SK..Z..LL 8010 / 9010	SH..B..LL 8010 / 9010 SH..S..LL 9010 / 9010 SH..Z..LL 9010 / 9010
511	Locking bolt	M 8 x 20		02.5071.23.00	●	●	●	●
542	Sensor bracket		A	03.189.14.86.0	●	●	●	●
560	Exciter ring	Ø 125 / 156 x 8.5 / Z = 100	B	03.310.08.51.0	●		●	●
		Ø 125 / 156 x 8.5 / Z = 80	B	03.310.08.53.0		●		
564	Clip	1 x 6		02.0326.32.00	●	●	●	●
565	Drive pin	Ø 4 x 10		02.6005.25.40	●	●	●	●
570	Sensor, straight	L = 350		02.3317.07.00	●	●	●	●
571	Bush			02.0316.59.00	●	●	●	●
585	Support	long - L 70		03.189.07.72.0	●	●	●	●
586	Support			02.1421.11.00	●	●	●	●
590	Heat protection plate			03.165.03.01.0	●	●	●	●
	Special silicone grease	3 g		02.1040.17.00	●	●	●	●

## 5.4 ABS retrofit part sets

ABS retrofit part sets for one axle consisting of exciter rings, sensors, sensor brackets, fastening components and mounting drawings.

**ABS-System**  
 Wabco / Bosch  
 also for:  
 Grau DGX / M  
 Grau MGX 100  
 Knorr

Axle type	Pitch circle (TK)	Remark	BPW Drawing	Brake	Exciter ring / teeth	Retrofit kit cpl. BPW Code no.
SKH.. 8008 - 9008	275	<input type="checkbox"/> 120	C-04.005.33.32.2	TSB 3709	80	05.801.74.55.0
SKH.. 8010 - 9010	335	<input type="checkbox"/> 120	C-04.005.33.32.2		100	05.801.74.54.0
SKH.. 10008	275	<input type="checkbox"/> 150	C-04.005.33.32.4		80	05.801.74.58.0
SKH.. 10010	335	<input type="checkbox"/> 150	C-04.005.33.32.4		100	05.801.74.57.0
SKHB.. 9010	335	<input type="checkbox"/> 120	C-04.005.33.32.3		100	05.801.74.56.0
SH.. 8010 - 9010	335	<input type="checkbox"/> 120	C-04.005.33.32.2	TSB 4309	100	05.801.74.54.0
SHB.. 9010	335	<input type="checkbox"/> 120	C-04.005.33.32.3		100	05.801.74.56.0

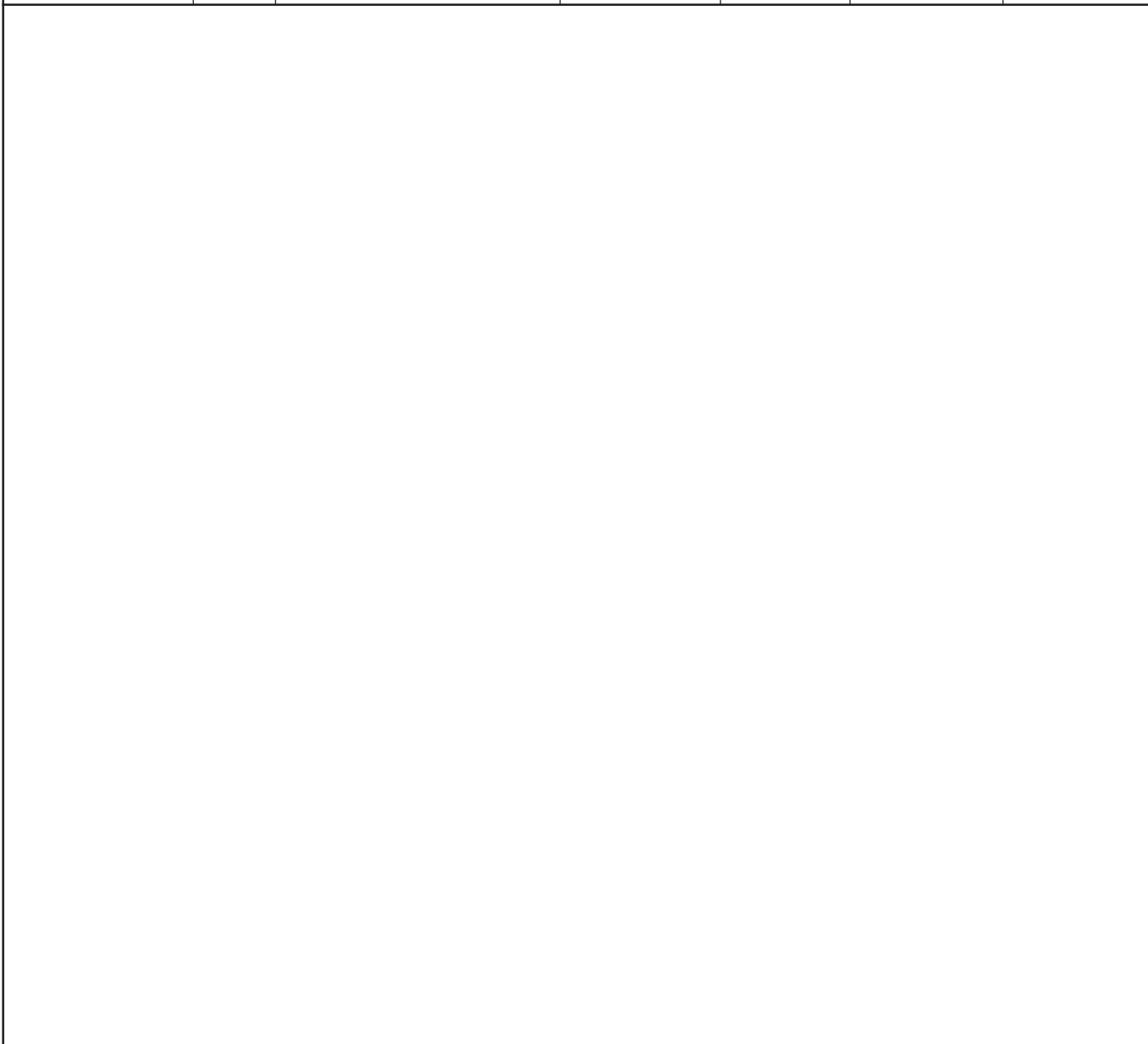



Notes

A large, empty rectangular box with a thin black border, intended for handwritten notes.

## 6.1 Wheel studs

View

### General

#### BPW wheel studs

The wheel nave (or wheel disc) connects the rim to the wheel hub. It must absorb the vertical, lateral and longitudinal forces which arise and transmit them to the wheel hub via the wheel studs (wheel bolts).

BPW axles with disc brakes are suitable for wheels with either bolt or hub centring, and with a few exceptions they are all supplied with helical bolts.

Helical studs are easy to maintain and connect the brake drum to the hub using a pressfit. As a result, there is no need for internal nuts.

The hub bore is not damaged even after several removal/installation operations (in contrast to the situation with splined studs) and the holding forces for the wheel studs remain constant.

The prescribed BPW tightening torques for wheel attachment are listed in the current BPW maintenance instructions and must be observed.

#### Assembly of the wheel bolts

The helical bolt is inserted from the rear through the hole in the brake disc / hub.

Then a sleeve is pushed over it, a wheel nut is applied and the wheel bolt is drawn into its final position.

 It is important to ensure that the flattened head of the wheel bolt sits correctly!

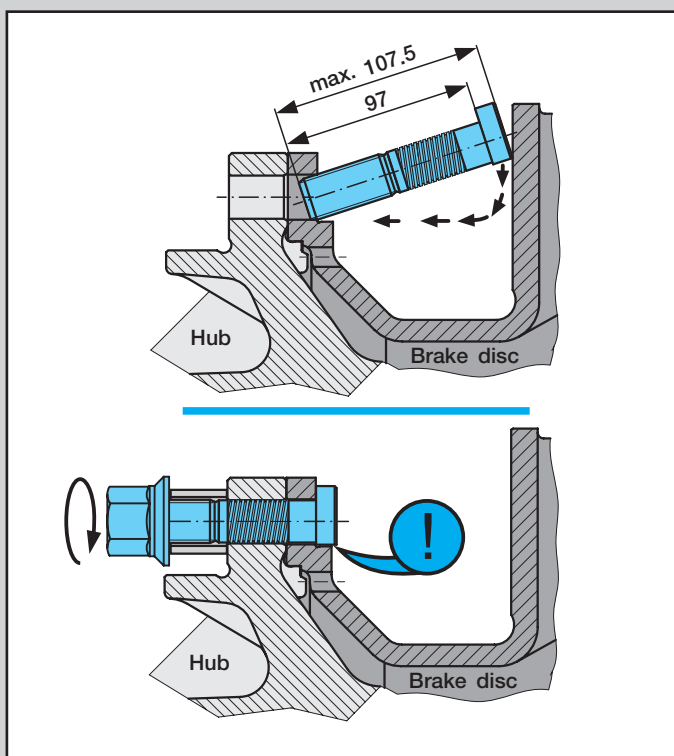
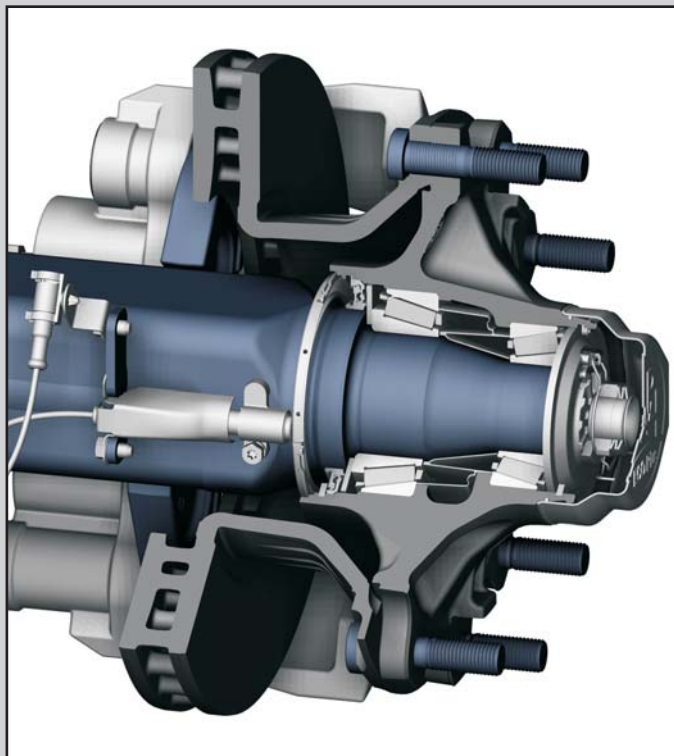

**Stud alignment**

In stud centring, the wheel nave (with countersunk stud holes) is centred using wheel studs with (spring) centring rings.

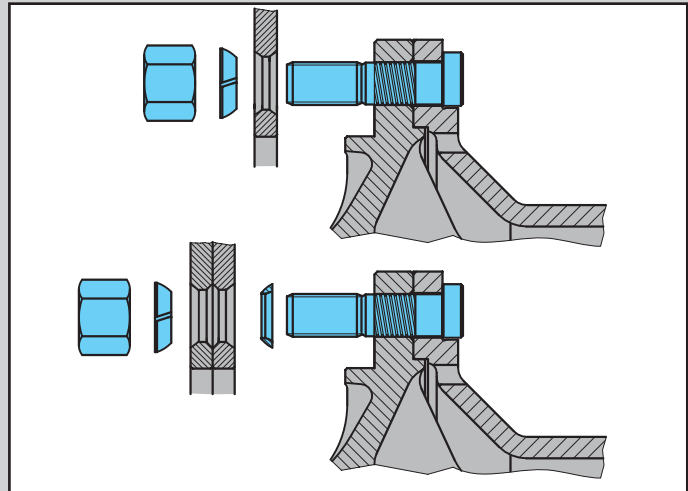

**Spigot alignment**

In hub centring, the wheel nave is centred using a centring spigot or ring surfaces on the wheel hub.

In the case of 8-hole disc wheels with countersunk stud holes and 10-hole disc wheels, a centring bush is mounted on 2 opposite wheel studs for each hub.

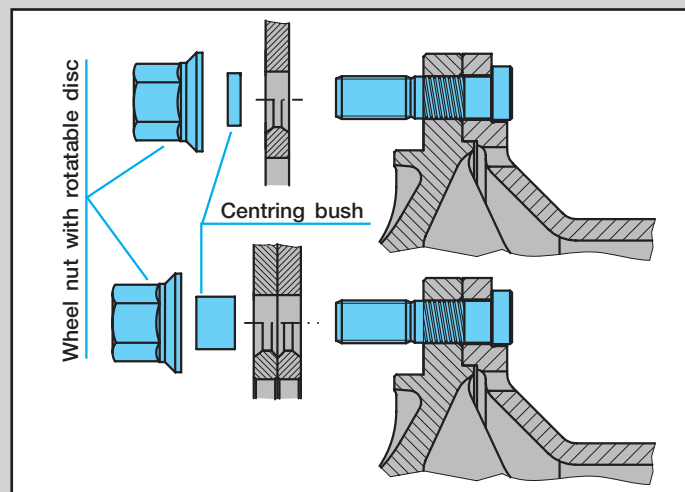

**Alloy wheels**

In the case of aluminium wheels, the wheel nave is centred using a centring cam or ring surfaces on the wheel hub.

As the flange thickness is greater with alloy wheels than with steel wheels, it is important to check whether the axles are suitable for fitting alloy wheels (with 26 mm-diameter hole).

In the case of twin tyres the available centring seat and wheel bolts must be of adequate length (i.e. the thread of the wheel nut must be completely engaged with the wheel bolt thread).

If not, aluminium wheels with stud hole  $\text{\O} 32$  can be used in conjunction with shaft nuts without replacing the hub or the wheel studs.

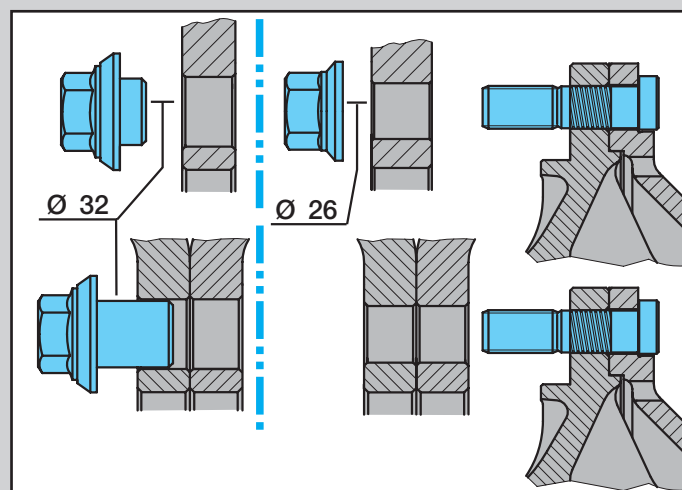

6.2 Wheel studs

Wheel studs																
Thread M 22 x 1.5 Wheel studs	Hub	Wheel type						Wheel nut			Fig.	item 470	Dimension wheel stud L / L1	item 472	item 476	item 476
	Steel hub	Steel wheel with offset	Steel wheel without offset	Alloy wheel Ø 26 with offset	Alloy wheel Ø 26 without offset	Alloy wheel Ø 32 with offset	Alloy wheel Ø 32 without offset	Stud alignment	Spigot alignment	normal SW 32		Cap nut SW 33		Shaft nut SW 32	Wheel stud assembly cpl. 09.806. (item 472 - 479)	Wheel stud 03.296.

Single wheels

Helical fit wheel bolt	●	●	●					●		●								
	●		●						●	●			1 A	33.75.0	80 / 45	33.11.1	-	-
	●		●							●	●		1 C	33.11.0	89 / 54	33.14.1	-	00.43.0
	●	●	●							●	●		1 C	33.76.0	80 / 45	33.11.1	-	00.43.0
	●		●							●		●	1 C	33.04.0	89 / 54	33.14.1	-	00.43.0
	●		●							●	●		1 C	33.77.0	80 / 45	33.11.1	-	00.43.0
	●			●	●					●			1 E	33.68.0	97 / 62	33.12.1	-	-
	●				●						●		1 E	33.69.0	97 / 62	33.12.1	-	-
	●					●						●	1 G	33.78.0	80 / 45	33.11.1	-	-
	●						●					●	1 G	33.79.0	97 / 62	33.12.1	-	-

Twin wheels

Helical fit wheel bolt	●		●					●		●								
	●		●					●		●			1 B	33.67.0	97 / 62	33.12.1	10.13.0	-
	●		●						●	●			1 D	33.68.0	97 / 62	33.12.1	-	00.42.0
	●						●					●	1 H	-	89 / 54	33.14.1	-	-
	●						●					●	1 H	-	97 / 62	33.12.1	-	-

<sup>1)</sup> Centring ring with helical fit wheel bolts and twin wheels.  
<sup>2)</sup> Bush not included in wheel stud assembly 09.806..... (see page 53).

item 478	item 479
Spring washer 02.5615.	Wheel nut

**Wheel studs**

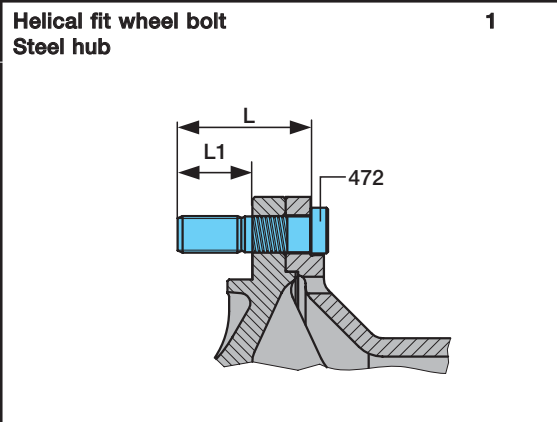

22.90	03.260.04.12.0
-	05.260.54.10.0
-	05.260.54.10.0
-	05.260.54.19.0
-	05.260.54.19.0
-	05.260.54.10.0
-	05.260.54.19.0
-	05.260.54.21.1
-	05.260.54.21.1

Single wheels	Twin wheels					
<b>Steel wheels</b> <b>Stud alignment</b> A	<b>B</b>	<b>Tightening torques for wheel nuts item 479</b> <table border="1"> <thead> <tr> <th>Thread</th> <th>Stud alignment</th> </tr> </thead> <tbody> <tr> <td>M 22 x 1.5</td> <td>510 Nm (485-535)</td> </tr> </tbody> </table>	Thread	Stud alignment	M 22 x 1.5	510 Nm (485-535)
Thread	Stud alignment					
M 22 x 1.5	510 Nm (485-535)					

22.90	03.260.04.12.0
-	05.260.54.10.0
-	05.260.54.14.1
-	05.260.54.14.1

<b>Steel wheels</b> <b>Spigot alignment</b> C	<b>D</b>	<b>Tightening torques for wheel nuts item 479</b> <table border="1"> <thead> <tr> <th>Thread</th> <th>Spigot alignment</th> </tr> </thead> <tbody> <tr> <td>M 22 x 1.5</td> <td>630 Nm (600-660)</td> </tr> </tbody> </table>	Thread	Spigot alignment	M 22 x 1.5	630 Nm (600-660)
Thread	Spigot alignment					
M 22 x 1.5	630 Nm (600-660)					

<b>Alloy wheels Ø 26</b> E		<b>Tightening torques for wheel nuts item 479</b> <table border="1"> <thead> <tr> <th>Thread</th> <th>Alloy wheels</th> </tr> </thead> <tbody> <tr> <td>M 22 x 1.5</td> <td>630 Nm (600-660)</td> </tr> </tbody> </table>	Thread	Alloy wheels	M 22 x 1.5	630 Nm (600-660)
Thread	Alloy wheels					
M 22 x 1.5	630 Nm (600-660)					

<b>Alloy wheels Ø 32</b> G	<b>Alloy wheels Ø 32</b> H	<b>Tightening torques for wheel nuts item 479</b> <table border="1"> <thead> <tr> <th>Thread</th> <th>Alloy wheels</th> </tr> </thead> <tbody> <tr> <td>M 22 x 1.5</td> <td>630 Nm (600-660)</td> </tr> </tbody> </table>	Thread	Alloy wheels	M 22 x 1.5	630 Nm (600-660)
Thread	Alloy wheels					
M 22 x 1.5	630 Nm (600-660)					

## 7.1 Steering dampers

View

### BPW Steering dampers

For BPW trailing steering axles, series ..LL, there are various steering damper parts kits.

A steering damper is absolutely essential under the following operating conditions:

- Where the ratio of the number of rigid axles to steering axles is 1:1 (2:2)
- Where an axle lift is used in the three-axle unit
- Where steering axle king pin bearings are connected to a central lubricating system.

The steering damper is easy to install and also to retrofit. Installation is carried out exclusively by means of bolts (no welding). The necessary attachment holes are present on the steering axles. Each parts kit also includes an installation drawing.

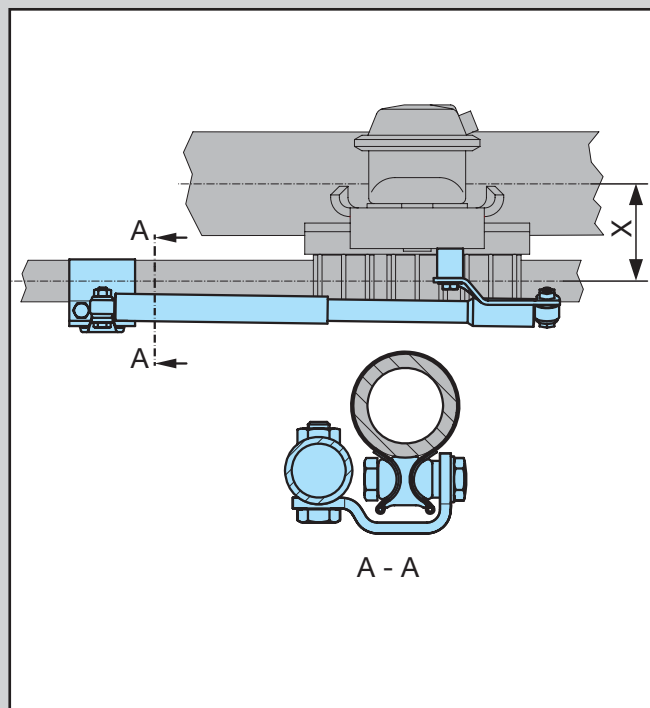



## BPW Steering dampers

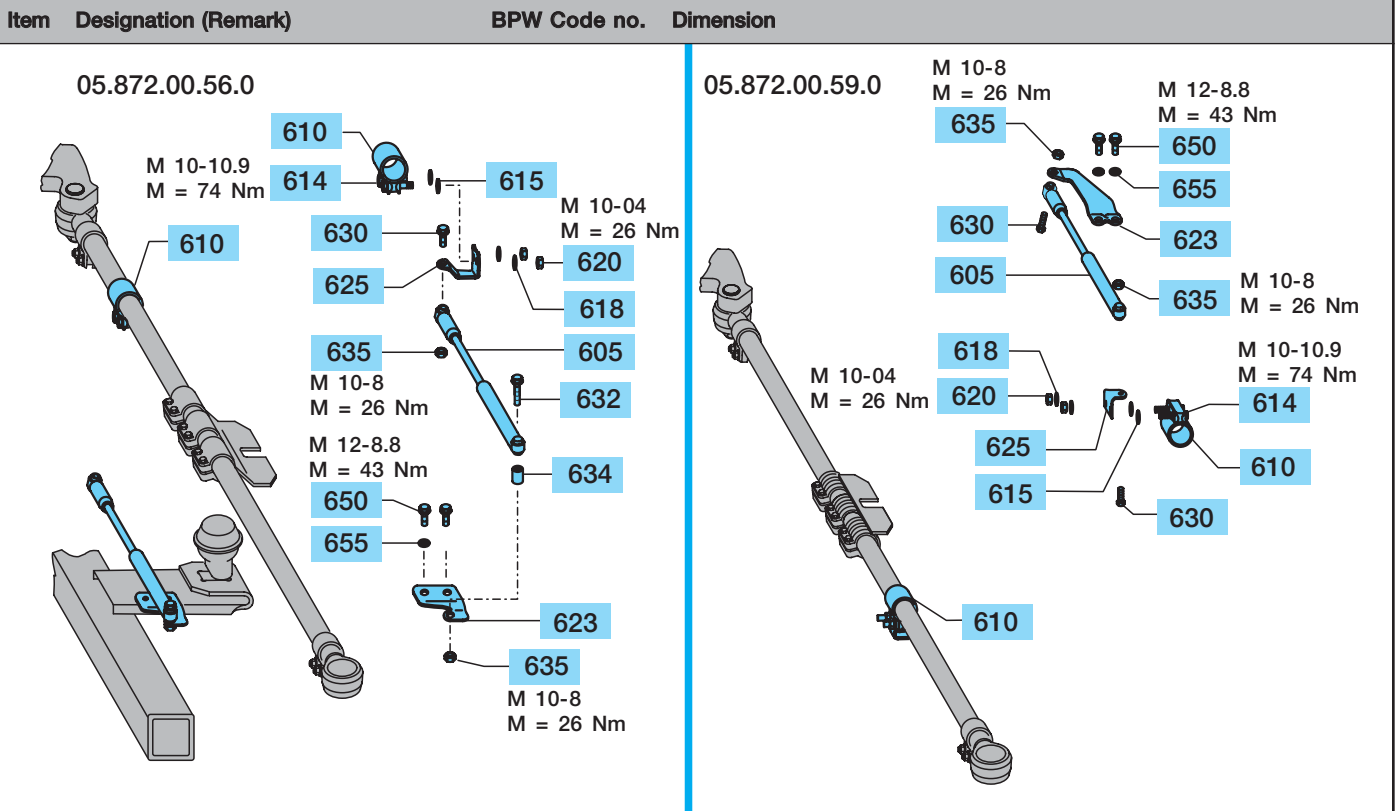

	Trailing arm above X = 163 / 171	Trailing arm below X = 25 / 35 / 45
600	Steering damper assembly (item 605 - 660) <b>05.872.00.56.0</b>	<b>05.872.00.59.0</b>
605	Steering damper 02.3702.93.00	02.3702.93.00
610	Clamp cpl. (incl. item 614) 05.001.00.03.0	05.001.00.03.0
614	Hexagon bolt 02.5025.56.11 M 10 x 50 - 10.9	02.5025.56.11 M 10 x 50 - 10.9
615	Ring 03.310.30.51.0 Ø 10.5 / 17 x 3.5	03.310.30.51.0 Ø 10.5 / 17 x 3.5
618	Lock washer 02.5403.10.92 B 10	02.5403.10.92 B 10
620	Hexagon nut 02.5205.03.24 M 10	02.5205.03.24 M 10
623	Shaped plate 03.165.56.35.0	03.165.35.12.0
625	Shaped plate 03.165.34.10.0	03.165.34.09.0
630	Hexagon bolt 02.5021.43.82 M 10 x 40 - 8.8	02.5021.43.82 M 10 x 40 - 8.8
632	Hexagon bolt 02.5021.50.82 M 10 x 70 - 8.8	-
634	Ring 03.310.30.68.0 Ø 10.2 / 13 x 30	
635	Lock nut 02.5273.10.82 M 10	02.5273.10.82 M 10
650	Hexagon bolt 02.5025.75.82 M 12 x 16 - 8.8	02.5025.75.82 M 12 x 16 - 8.8
655	Lock washer 02.5403.12.92 B 12	02.5403.12.92 B 12

### 8.1 Hubcaps with integrated Hubodometer

Axle load	Axle series	Axle type	Hubcap thread	for tyre e.g.	Developed area	Hubcap with integrated Hubodometer BPW Code no.
10 - 12 t	SH.. SH..LL SM..LL	SH.. ECOPlus	M 136 x 2.5	255 / 70 R 22.5	2830 - 2860	05.212.25.41.0
				275 / 70 R 22.5	2915	05.212.25.42.0
				385 / 55 R 22.5	3015 - 3134	05.212.25.44.0
				315 / 70 R 22.5		
				10.00 R 20	3175 - 3220	05.212.25.45.0
				11.00 R 22.5		
				385 / 65 R 22.5	3240 - 3260	05.212.25.46.0
				12.00 R 22.5	3280 - 3310	05.212.25.47.0
				425 / 65 R 22.5	3410 - 3470	05.212.25.48.0
				13.00 R 22.5		
445 / 65 R 22.5	3505	05.212.25.49.0				
8 - 9 t		SH.. ECO Plus 2	Bayonet lock	385 / 55 R 22.5	3015 - 3134	05.212.25.73.0
				315 / 70 R 22.5		
				11.00 R 22.5	3175 - 3220	05.212.25.74.0
				385 / 65 R 22.5	3240 - 3260	05.212.25.75.0
10 - 12 t	SKH.. SKH..LL SKM..LL	SKH.. ECOPlus	M 136 x 2.5	265 / 70 R 19.5	2620 - 2650	05.212.25.38.0
				285 / 70 R 19.5	2712 - 2750	05.212.25.39.0
				445 / 45 R 19.5	2730 - 2790	05.212.25.40.0
				425 / 55 R 19.5	2960	05.212.25.43.0
8 - 9 t		SKH.. ECO Plus 2	Bayonet lock	445 / 45 R 19.5	2730 - 2790	05.212.25.72.0

## Hubcaps with digital odometer (ECOMETER) 8.2



The BPW hubcap with its integrated digital odometer is an important instrument for checking the mileage of your trailer or semitrailer.

This means you can always track the real trailer mileage, especially when the trailer is used with different tractor units.

The digital ECOMETER can be used universally for all tyre sizes.

The adjustment of the wheel size is carried out by means of the display unit (basic setting 385/65 R 22.5).

A built-in watertight mini-computer counts the wheel revolutions by means of a magnet and a reed contact.

The digital ECOMETER with the special hooked spring ring and integrated magnet is available for all BPW ECOPlus axles with an M 136 x 2.5 hubcap thread, as well as ECO Plus 2 axles with a bayonet fitting.



	BPW Code no.:	
Thread M 136 x 2.5		05.212.75.02.0 KTL <sub>Zn</sub>
Bayonet lock		05.212.75.05.0 KTL <sub>Zn</sub> incl. 'O'-Ring
Circlip loose		
	ECOPlus	05.188.04.13.0
	ECO Plus 2	05.277.10.03.0
Replacement battery		02.0130.97.00

Further information see service and installation instruction 'Digital ECOMETER' - BPW No.: 04.001.21.24.0 and 04.001.21.25.0.

## 9 Special tools for BPW ECO Disc Trailer disc brakes

### BPW Special tools and calibration equipment

Special tools and measuring devices have a long tradition at BPW Bergische Achsen KG, based on decades of experience.

The existing range of tools has been systematically improved and new products have been added to it with every new generation of axles.

BPW offers a tool case (BPW Code no. 99.00.000.9.63) for service and repair of the BPW ECO Disc Trailer disc brakes, containing all tools that might be required.

In addition to which BPW offers special measuring devices for checking dimensions on axles and suspensions.

### Tried and tested design

Tools must prove their worth in hard, everyday use.

Only then does it become clear whether tools are up to the demands of the real world.

### Use of high-quality materials

High-quality materials are absolutely essential for producing high-quality tools.

Continuous quality assurance guarantees consistent quality.

### Favourable price/performance ratio

Quality is not always obvious at first glance (e.g. materials).

Buying quality tools is often the most cost effective long term option.

This particularly applies in those cases where tools are regularly needed and where their trouble-free use must be guaranteed at all times.

- The special tools ensure that all recommended service work on the BPW ECO Disc (TSB 3709 / TSB 4309 / TSB 4312) can be performed safely and easily.
- All work on the vehicle is only allowed to be performed by employees of the commercial vehicle industry and the commercial vehicle trade who have the appropriate technical proficiency. Always follow the safety instructions issued by the vehicle manufacturer.



### Long service life, low wear

BPW tools are designed to be particularly resistant to wear and tear, and guarantee an extremely long service life, even with frequent use.

### Simple to handle

Ideal solutions are always simple. This statement also particularly applies to tools. For that reason BPW tools are specifically designed to meet the technical requirements. Solutions that do not meet practical requirements are rigorously weeded out at the development stage.





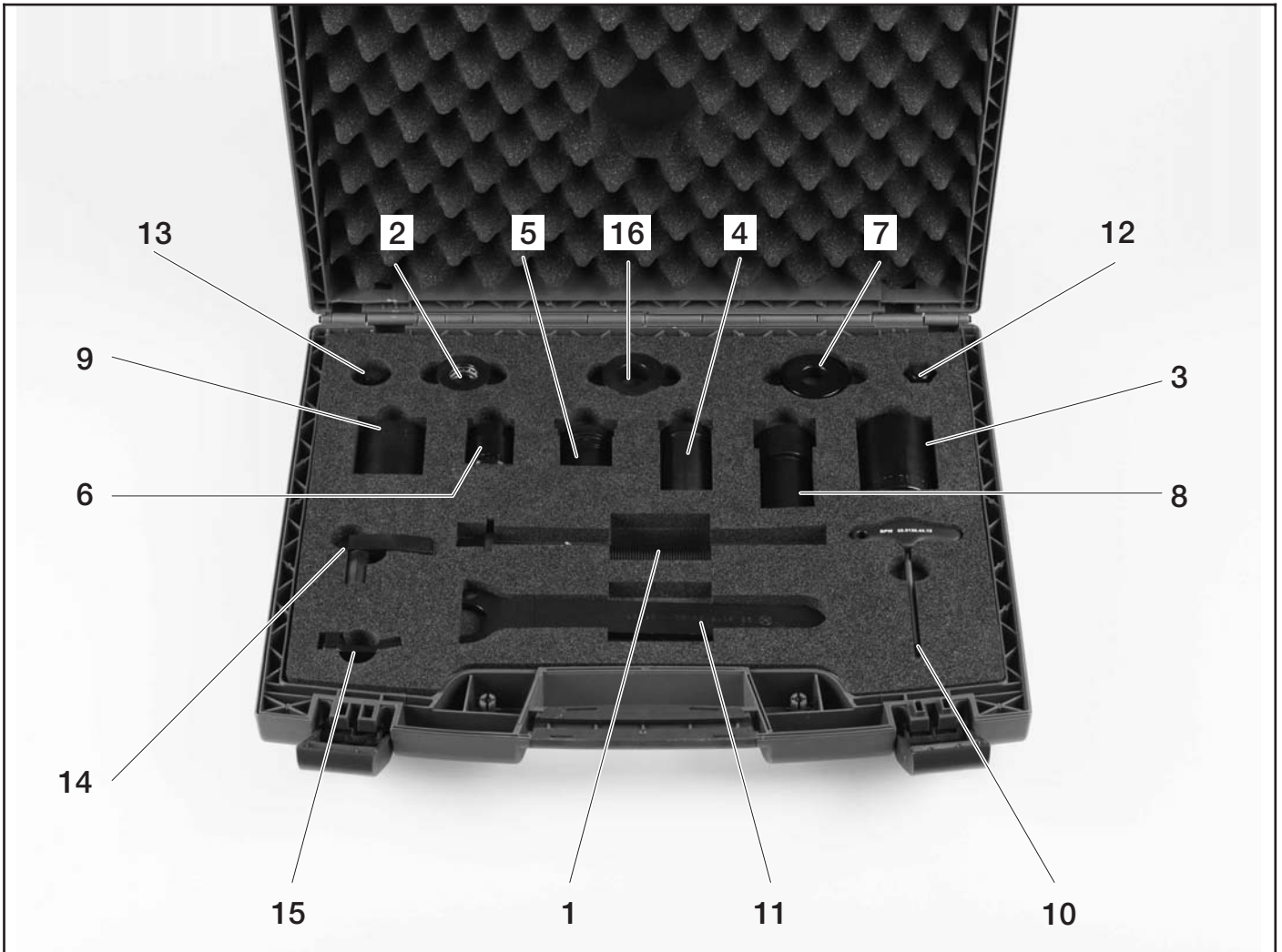

Details on the correct use of the tools can be found in the respective workshop manuals. For more tools see the BPW tools catalogue.

## Contents of ECO Disc tool case 9.1

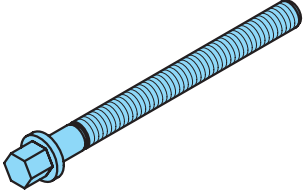
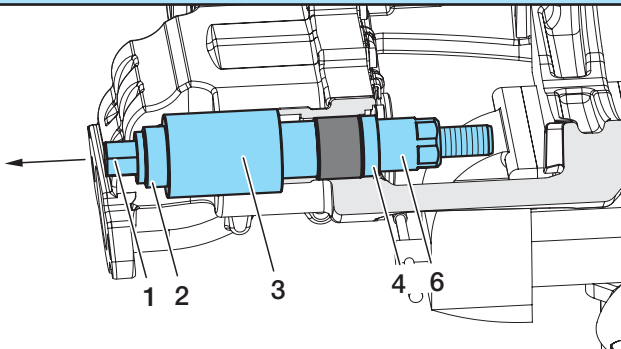

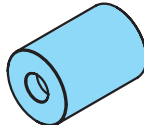
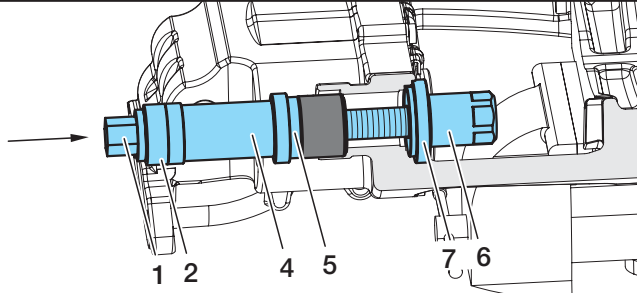

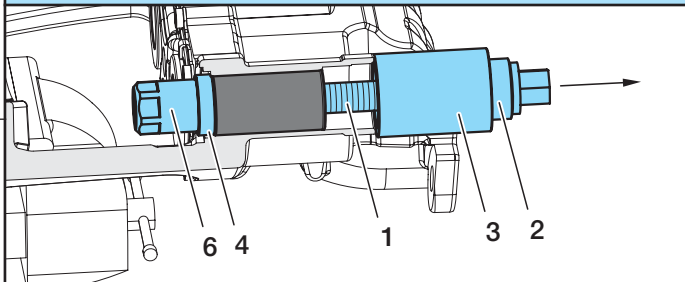

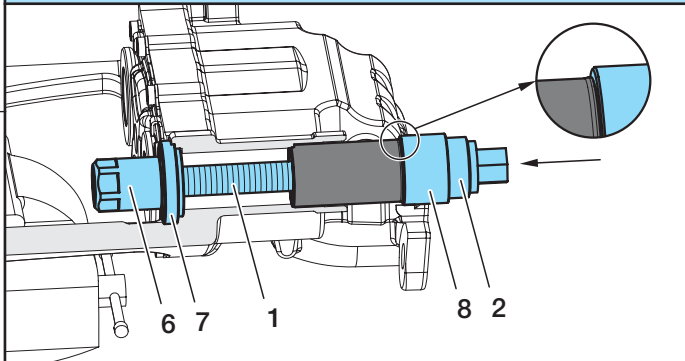
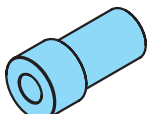

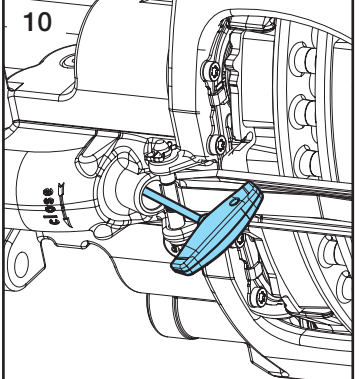
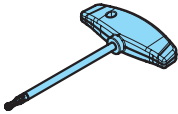
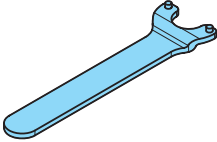
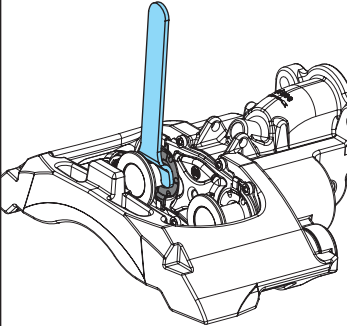
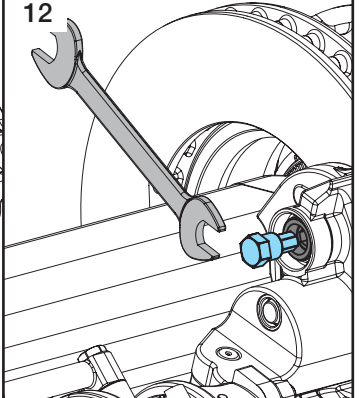

Item	Designation	BPW Code no.	Page
1	Threaded spindle	02.0130.39.10	62
2	Ball bearing	02.0130.40.10	62
3	Sleeve	02.1410.26.00	62
4	Press-out tool for movable and fixed bearings	02.0130.41.10	62
5	Pressing tool (movable bearing)	02.0130.42.10	62
6	Nut	02.5270.37.00	62
7	Counter-hold tool	02.1421.22.00	62
8	Pressing tool (fixed bearing)	02.0130.43.10	62
9	Press-on tool (plastic bellows)	02.0130.45.10	63
10	Torx spanner return mechanism	02.0130.44.10	63
11	Two-hole spanner for coarse dirt seal	02.3516.20.00	63
12	Adapter for movable bearing screw	02.0130.46.10	63
13	Adapter for plastic cap	02.0130.47.10	63
14	Adapter for torque wrench (movable bearing)	02.0130.48.10	63
15	Adapter for torque wrench (plastic cap)	02.0130.49.40	63
16	Ring for pulling in wheel studs	02.5683.92.00	63

9 Special tools for BPW ECO Disc Trailer disc brakes

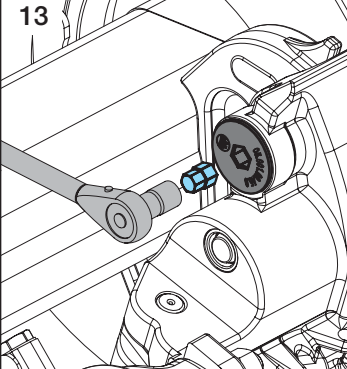
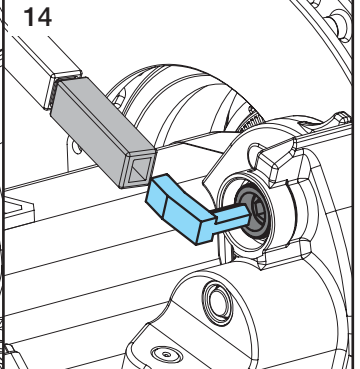
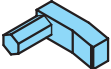
BPW special tools at work		
Item / BPW Code no. / Designation / Dimension		
<p>1</p> <p>02.0130.39.10</p> <p>Threaded spindle</p> <p>M 18 / SW 22</p>		<p><b>Press-out tool for movable bearing, consisting of item 1, 2, 3, 4, 6</b></p> 
<p>2</p> <p>02.0130.40.10</p> <p>Ball bearing</p>		
<p>3</p> <p>02.1410.26.00</p> <p>Sleeve</p> <p>Ø 20.5 / Ø 42 / Ø 55</p>		<p><b>Pressing tool for movable bearing, consisting of item 1, 2, 4, 5, 6, 7,</b></p> 
<p>4</p> <p>02.0130.41.10</p> <p>Press-out tool for movable and fixed bearings</p>		
<p>5</p> <p>02.0130.42.10</p> <p>Pressing tool (movable bearing)</p>		<p><b>Press-out tool for fixed bearing, consisting of item 1, 2, 3, 4, 6</b></p> 
<p>6</p> <p>02.5270.37.00</p> <p>Nut</p> <p>M 18 SW 32</p>		
<p>7</p> <p>02.1421.22.00</p> <p>Counter-hold tool</p>		<p><b>Pressing tool for fixed bearing, consisting of item 1, 2, 6, 7, 8</b></p> 
<p>8</p> <p>02.0130.43.10</p> <p>Pressing tool (fixed bearing)</p>		
<p>SW = Spanner width</p>		

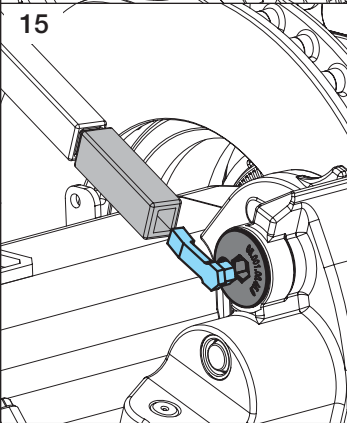
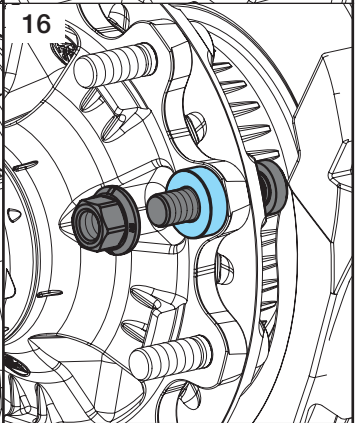
## Special tools for BPW ECO Disc Trailer disc brakes 9.2

BPW special tools at work			
Item / BPW Code no. / Designation / Dimension			
<b>9</b> 02.0130.45.10 Press-on tool (plastic bellows)		<b>9</b> 	<b>10</b> 
<b>10</b> 02.0130.44.10 Torx spanner return mechanism			
<b>11</b> 02.3516.20.00 Two-hole spanner for coarse dirt seal		<b>11</b> 	<b>12</b> 
<b>12</b> 02.0130.46.10 Adapter for movable bearing screw SW 14 / SW 24			
<b>13</b> 02.0130.47.10 Adapter for plastic cap SW 14 / SW 13		<b>13</b> 	<b>14</b> 
<b>14</b> 02.0130.48.10 Adapter for torque wrench (movable bearing) SW 14			
<b>15</b> 02.0130.49.10 Adapter for torque wrench (plastic cap) SW 14		<b>15</b> 	<b>16</b> 
<b>16</b> 02.5683.92.00 Ring for pulling in wheel studs			
SW = Spanner width			

Notes







BPW-EL-TSB 31081001e

