

H
K
N

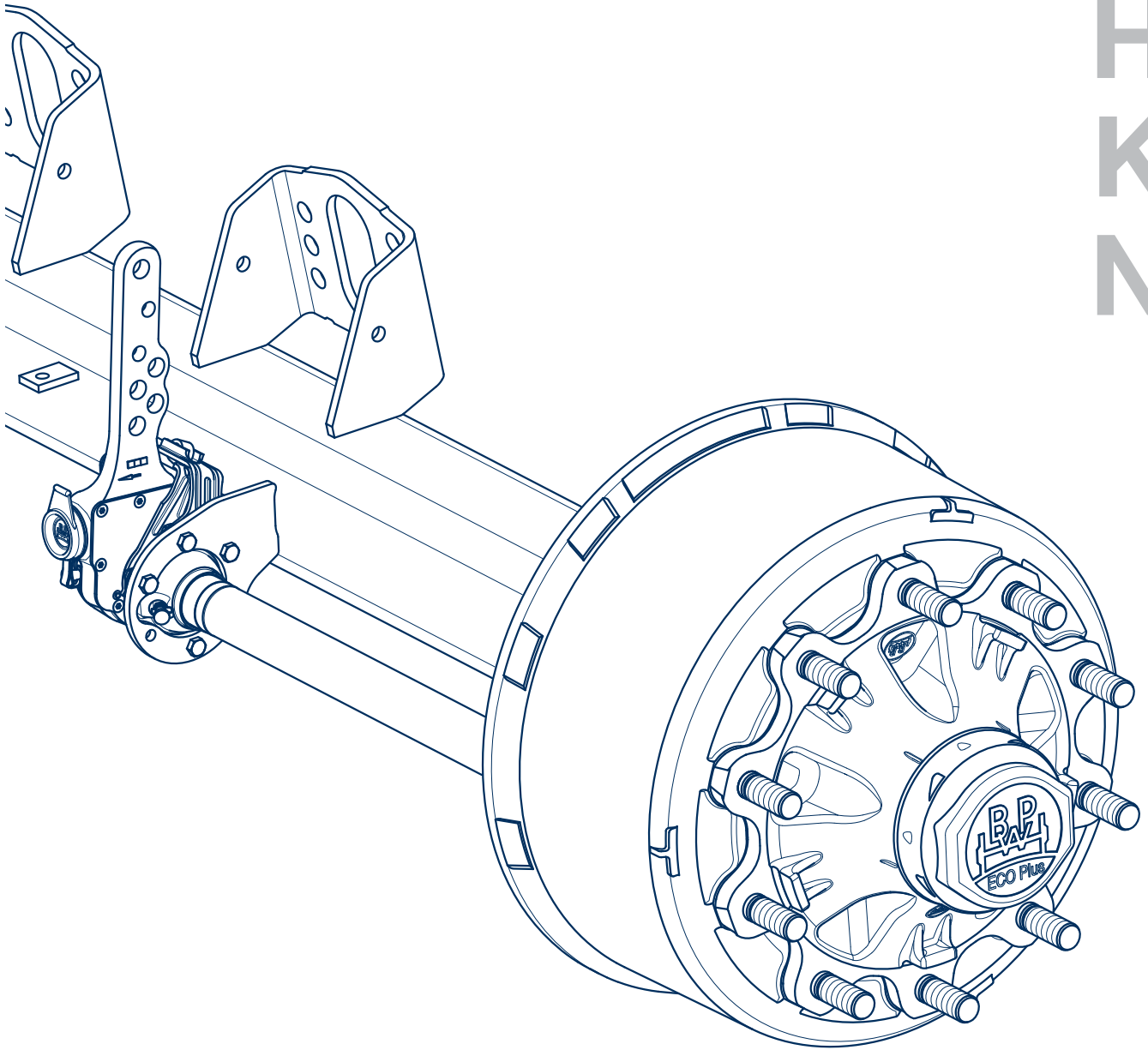

BPW Original spare parts

BPW trailer axles series H.. / K.. / N..
with drum brakes



BPW-EL-HKN 31021401e

BPW · THE QUALITY FACTOR





BPW-EL-HKN 31021401e

BPW is a globally leading manufacturer of intelligent running gear systems for trailers and semi-trailers. As an international mobility and system partner, we offer a wide range of solutions for the transport industry from a single source, from axle to suspension and brake to user-friendly telematics applications.

We thereby ensure outstanding transparency in loading and transport processes and facilitate efficient fleet management. Today, the well-established brand represents an international corporation with a wide product and service portfolio for the commercial vehicle industry. Offering running gear systems, telematics, lighting systems, composite solutions and trailer superstructures, BPW is the right system partner for automotive manufacturers.

BPW, the owner-operated company, consistently pursues one target: To always give you exactly the solution which will pay off. To this end, we focus our attention on uncompromising quality for high reliability and service life, weight and time-saving concepts for low operating and maintenance costs as well as personal customer service and a close-knit service network for quick and direct support. You can be sure that with your international mobility partner BPW, you always use the most efficient method.

Your partner on the path to economic viability



BPW Bergische Achsen Kommanditgesellschaft

Postbox 12 80 · 51656 Wiehl, Germany · Phone +49 (0) 2262 78-0
info@bpw.de · www.bpw.de

Contents

		Page		
		Axle series		
		H.. / R.. Ø 420	K.. Ø 360	N.. Ø 300
Explanation of BPW axle type codes		4		
Explanation of BPW axle code numbers		5		
⊙ 1	Axle beam	6 - 9		
1.1	Axle beams, booster brackets	8 / 9	8 / 9	8 / 9
⊙ 2	Brake camshafts, brake camshaft bearings	10 - 19		
2.1	Brake camshafts	12	12	13
2.2	Brake camshaft bearings	14 - 19	14 - 19	14 - 19
⊙ 3	Slack adjusters	20 - 29		
3.1	Manual slack adjusters type GSK, return springs	22	22	22
3.2	Automatic slack adjusters type ECO-Master (AGS)	23 / 24	23 / 25	23 / 26
3.3	Installation instructions ECO-Master (AGS)	27	27	27
3.4	Slack adjuster attachments	28 / 29	28 / 29	28 / 29
⊙ 4	Brake parts	30 - 55		
4.1	Brake parts SN-2, retrofit kits	34 / 35	36 / 37	38 / 39
4.2	Brake parts for brake BPW 95 / ECO Drum	40 / 41	42 / 43	44 / 45
4.3	Brake drums	46	47	47
4.4	Brake drum attachments	48	48	49
4.5	Brake dust covers	50 / 51	52 / 53	52 / 53
4.6	Brake cylinders	54 / 55	54 / 55	54 / 55
⊙ 5	Hubs, hub bearings	56 - 81		
5.1.1	Hub bearings, conventional hub bearing system	60 - 63	60 - 63	64 / 65
5.1.2	Hub bearings, ECO / ECO-MAXX hub system	66 / 67	66 / 67	66 / 67
5.1.3	Hub bearings, ECO ^{Plus}	68 / 69	68 / 69	-
5.1.4	Hub bearings, ECO Plus 2	70 / 71	70 / 71	70 / 71
5.2.1	Hubs, conventional hub bearing system	72	72	72
5.2.2	Hubs, ECO / ECO-MAXX hub system	73	73	74
5.2.3	Hubs, ECO ^{Plus} hub system	75	75	-
5.2.4	Hubs, ECO Plus 2 hub system	76	76	76
5.3.1	Grease filling, bearing adjustment, conventional	77	77	77
5.3.2	Grease filling, bearing adjustment, ECO / ECO MAXX	78	78	78
5.3.3	Grease filling, bearing adjustment, ECO ^{Plus}	79	79	-
5.3.4	Grease filling, bearing adjustment, ECO Plus 2	80	80	80
5.4	Grease sprays for greasing taper roller bearings	81	81	81
⊙ 6	ABS	82 - 95		
6.1	ABS parts / ABS retrofit part sets	84 - 87	88 - 91	92 - 95
⊙ 7	TRILEX	96 / 97	-	-
⊙ 8	Wheel studs	98 - 103		
8.1	Wheel studs, single wheels	100 / 101	100 / 101	100 / 101
8.2	Wheel studs, twin wheels	102 / 103	102 / 103	102 / 103
⊙ 9	Accessory	104 - 106		
9.1	Hubcaps with integrated Hubodometer	104 / 105	104 / 105	104 / 105
9.2	Hub caps with digital odometer (ECOMETER)	106	106	106

Valid: 1.8.2014

This spare parts list shows fast moving parts for BPW trailer axles series H.. / K.. / N.. 6.5 - 18 tons from 1983 (1982) onwards. Additional spare parts as per spare parts catalogue.

Current versions and additional informations can be found online at www.bpw.de.



Subject to change (without notice).

⊙ -parts are embossed with BPW Code no.

Contents (Exploded view)

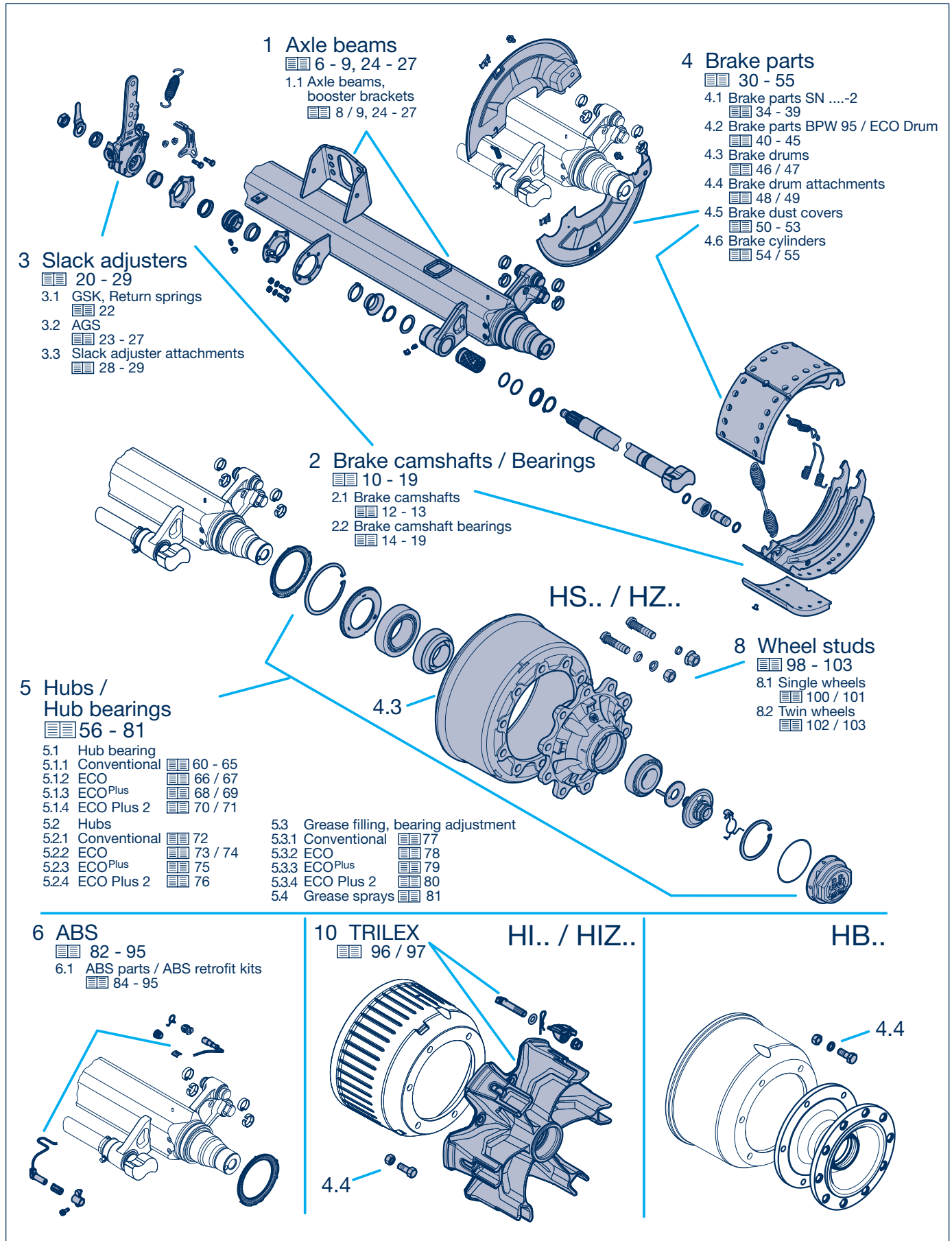

Explanation of BPW axle type codes

Extract

Riveted type plate up to year of manufacture 1999

Labels: Axle type, BPW Code number, Date and serial number, Brake type, Certificate type, Test report no., Max. static axle load on ground

Adhesive type plate from year of manufacture 2000

Labels: zul. Achslast perm. axle capacity charge adm., STAT. 9000, v max. km/h max. speed vitesse maxi. 105

Type plate from year of manufacture 2006 (Adhesive type plate) with barcode

Labels: zul. Achslast perm. axle capacity charge adm., stat. 9000 kg 105 km/h

Example:

H	S	F	A	H	9010	-15	ECO				
								Axle series	Axle beam	Brake	Tyre
H								H..	□		
R								R..	○	SN 420	20 - 24"
KH								KH..	□		
KM								KM..	■		
KR								KR..	○	SN 360	19.5"
KRD								KRD..	●		
NH								NH..	□		
NR								NR..	○	SN 300	15 / 17.5"
NRD								NRD..	●		
B								For single wheels, wheels with offset			
S								For single wheels, wheels without offset			
Z								For twin wheels			
I								Wheel spiders for TRILEX wheel rims, single wheels			
IZ								Wheel spiders for TRILEX wheel rims, twin wheels			
F								Wheel studs M 22 x 1.5 without wheel nuts, order wheel nuts for stud or spigot alignment separately			
M								For spigot alignment			
	A							With alloy hubs			
		(D)						(German Dauerbremse)			
			H					For hanging boosters			
				6006 to 18010				Axle load (kg) + quantity of wheel studs per hub			
					-15			Axle beam - wall thickness, e.g. 15 mm			
						-1		Type of hub bearing (e.g. 14 t)			
						/3		Wheel connection - 10 wheel studs, pitch circle 335 mm (only K..)			
							ECO	ECO hub system			
							ECO-MAXX	Weight optimized trailer axle with ECO hub system			
							ECO ^{Plus}	Weight optimized trailer axle with ECO ^{Plus} hub system			
							ECO Plus 2	Weight optimized trailer axle with ECO Plus 2 hub system			
							MAXX	Weight optimized trailer axle with conventional hub bearing system			

Explanation of BPW axle code numbers

Extract

Example:						
30.	38.	743.	000			
20.				Trailer axle without suspension parts		
24.						
25.						
27.						
30.						
31.						
				Axle load	Roller bearing	
06.				6500 kg	33116 / 32310	Conventional hub bearing system
08.				8000 - 9000 kg	33116 / 32310	
09.						
10.				10000 - 12000 kg	33118 / 33213	
14.				13000 - 14000 kg	32219 / 33215	
16.				16000 - 18000 kg	32222 / 32314	
36.				6500 kg	33116 / 32310	ECO / ECO-MAXX hub system
38.				8000 - 9000 kg	33116 / 32310	
40.				10000 - 12000 kg	33118 / 33213	
41.						
44.				13000 - 14000 kg	32219 / 33215	ECO ^{Plus} hub system
48.				8000 - 9000 kg	33118 / 33213	
50.				10000 - 12000 kg	33118 / 33213	
51.						ECO Plus 2 hub system
56.				6500/7000 kg	33118 / 33213	
58.				8000 - 9000 kg	33118 / 33213	Conventional hub bearing system
59.						
65.				6400 kg	33215 / 32310	
				Wheel brake type	Dimensions	Execution
582.				SN 3015-1 HWG closed	Ø 300 x 150	Brake shoes with closed anchor eye (old type) up to 1989
586.				SN 3020-1 HWG closed	Ø 300 x 200	
592.				SN 3015 HWG closed	Ø 300 x 150	Quick-release brake shoes from 1990 onwards
596.				SN 3020 HWG closed	Ø 300 x 200	
501.				SN 3015 BPW 95 closed	Ø 300 x 150	Brake shoes with split roller (BPW 95)
502.				SN 3020 BPW 95 closed	Ø 300 x 200	
542.				SN 3616 closed	Ø 360 x 160	Brake shoes with split roller (BPW 95)
546.				SN 3620 closed	Ø 360 x 200	
551.				SN 3616 BPW 95 closed	Ø 360 x 160	
552.				SN 3620 BPW 95 closed	Ø 360 x 200	
790.				SN 4212-2 HWG open	Ø 420 x 120	Brake shoes with split roller (BPW 95 / ECO Drum)
794.				SN 4212-2 HWG closed	Ø 420 x 120	
710.				SN 4218-2 HWG open	Ø 420 x 180	
714.				SN 4218-2 HWG closed	Ø 420 x 180	
718.				SN 4220-2 HWG open	Ø 420 x 200	
723.				SN 4220-2 HWG closed	Ø 420 x 200	
739.				SN 4222-2 HWG closed	Ø 420 x 220	
741.				SN 4212 closed	Ø 420 x 120	
743.				SN 4218 closed	Ø 420 x 180	
744.				SN 4220 closed	Ø 420 x 200	
745.				SN 4222 closed	Ø 420 x 220	
000				Consecutive number 000 - 999		

H

K

N

1 Axle beam

General

BPW Axle beams

Square, reliable, light – the BPW axle beam. It's the stable foundation for a long vehicle life. And in combination with our brakes and suspension systems, the square axle produces axle systems which offer convincing all round performance with long service lives and maintenance intervals.

The BPW square axle beam consists of two high-quality, specially rolled "U" sections which are welded together inside and out.

The special feature of the BPW standard axle tube with a 120 mm axle cross-section is its Q.U.A.D. profile (Quality Upgraded Advanced Design). This profile features more material at the corner radii and less material in the top and bottom areas. As a result, the axle cross-sections are reinforced at the points where the force is applied and are optimally shaped to cope with the load.

The Q.U.A.D. profile ensures that the maximum service life can be achieved. BPW axle tubes are available with various cross-sections and wall thickness values depending on the axle load and the application conditions.

BPW axle stubs are forged, quenched and tempered. They have two stepped bearing seats.

The axle stubs and axle tube are flash butt welded together to produce the one piece BPW axle beam.

In this welding process, the axle tube and the ends of the axle stubs are heated up to welding temperature by an electric current applied at their joining faces, whilst at the same time being forced together.

This produces an absolutely homogeneous connection without any inclusions. In contrast to conventional welding processes, no filler metals are needed.

At the same time, the axle beam is given its camber and toe-in.

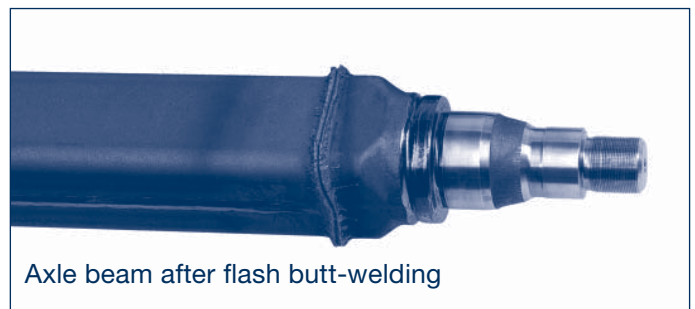
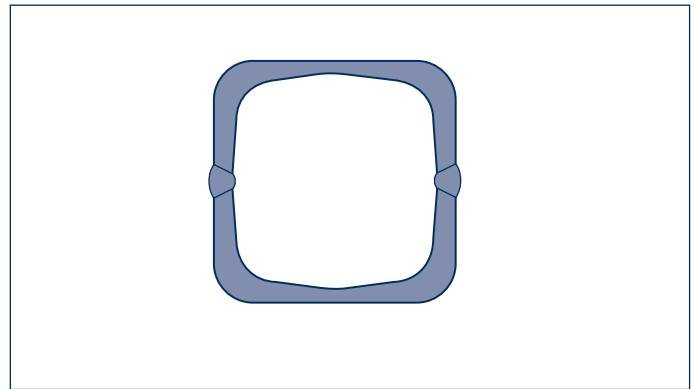
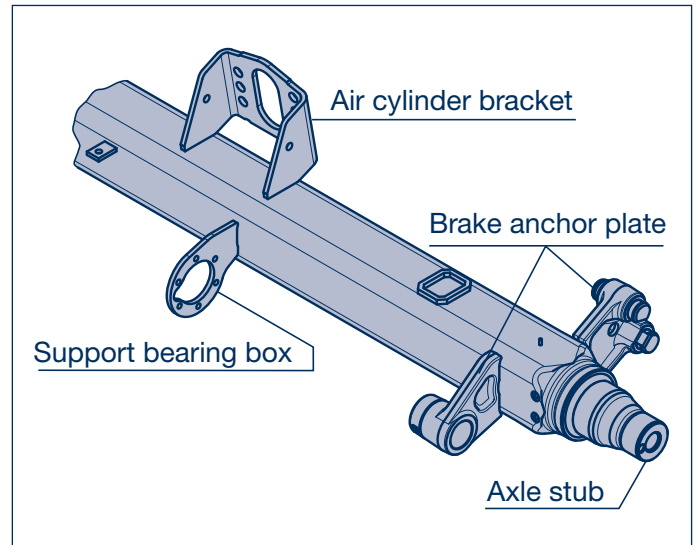

Axle beam after flash butt-welding



Axle beam after removing the welding flash

Axle beam 1

Determining replacement axle beams

Determining replacement axle beams

The BPW axle number is shown on the type plate.

If this is missing or no longer legible, the BPW axle number can be read off the front end of the axle stub in most cases.

When ordering the axle beam, quote this BPW axle number with the reference to a replacement axle beam.

In steering axles and ECO Plus 2 bearings, there is no code number embossed on the front end of the stub.

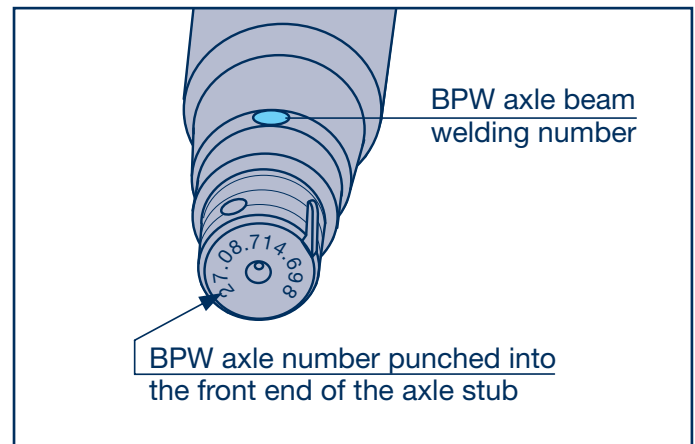

If there is no BPW axle number or none is known, BPW can identify the axle on the basis of the axle beam welding number (see also BPW Internet application for spare part lists for commercial vehicles) or the dimensions.

1. **Axle beam cross section** (□ 120 / 150, Ø 127)
2. **Axle beam wall thickness** (if known)
3. **Booster bracket centre** (GM)
4. **Spring centre** (FM)
5. **Track** (SP)
6. **Overall width** (P)
7. **Leaf spring width** (FB)
8. **Spring pad hole pattern** (C and D) (if present)
9. **Wheel seat** (H)
10. **Pitch circle and number of wheel studs**

In addition to which the **type of tyres**, the **wheel size** and the **brake size** should also be specified, as well as the approximate **year of manufacture** (initial registration).

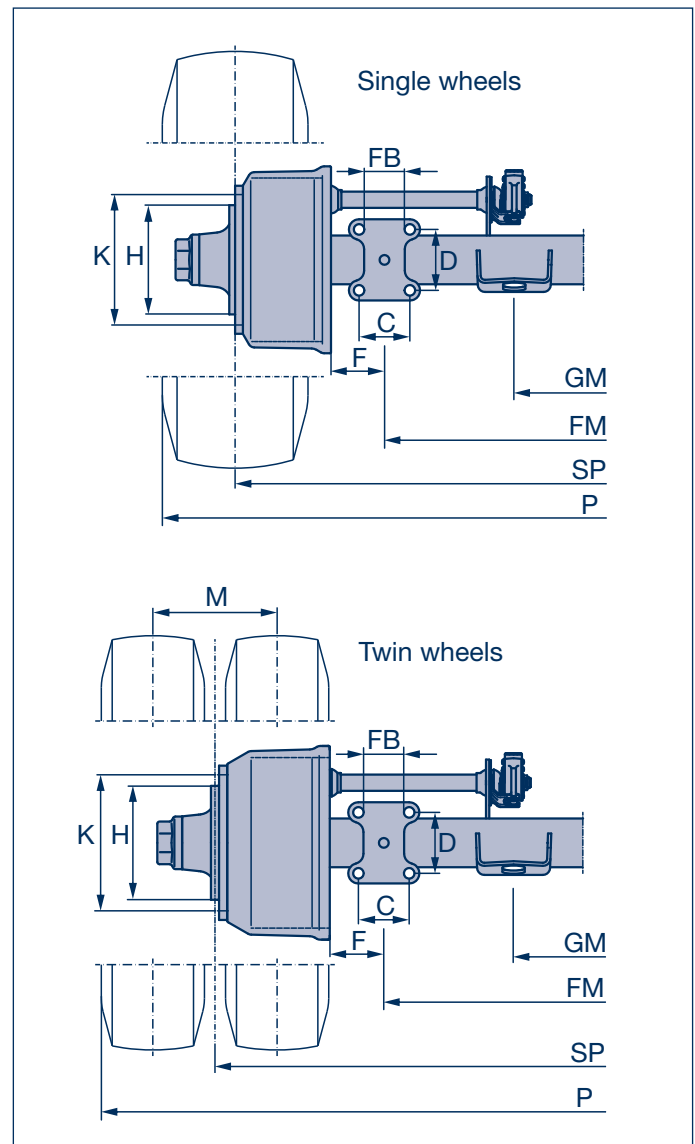

1 Axle beam

1.1 Axle beams, booster brackets

H
K
N

H.. / KH.. Conv. / ECO
Brake ...-1 / 2

H.. / KH.. ECO / ECO Plus / ECO Plus 2
Brake with split roller (BPW 95 / ECO Drum)

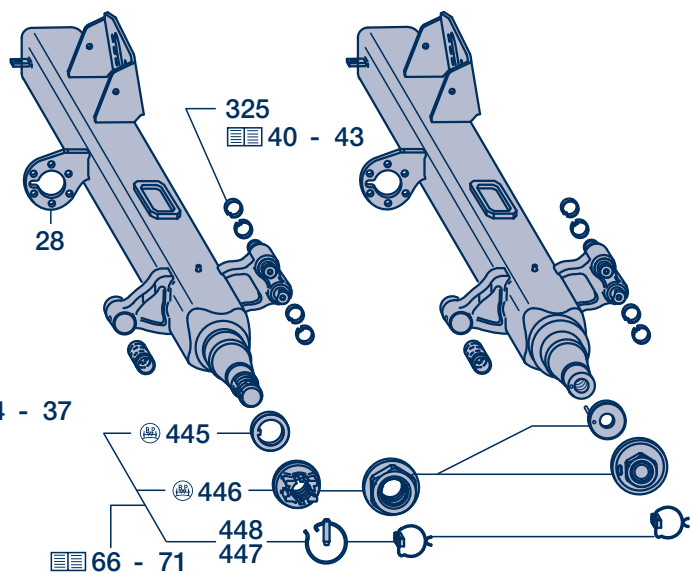
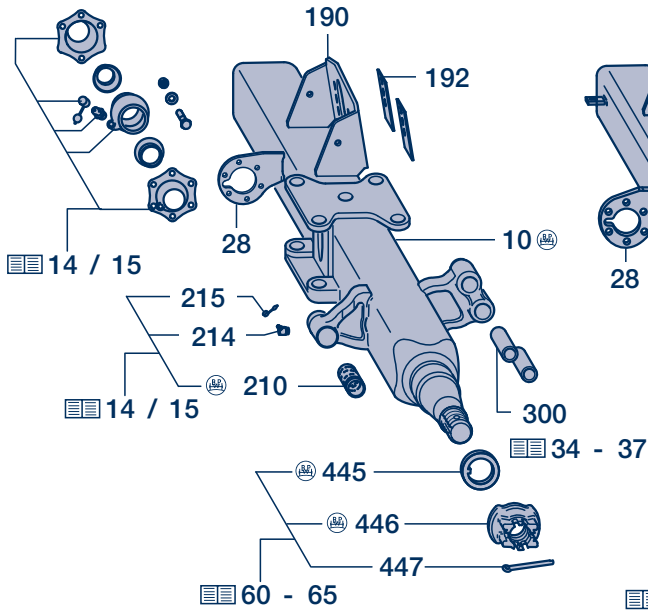

NR.. Conv. / ECO
Brake ...-1 / 2

NH.. ECO
Brake with split roller (BPW 95)

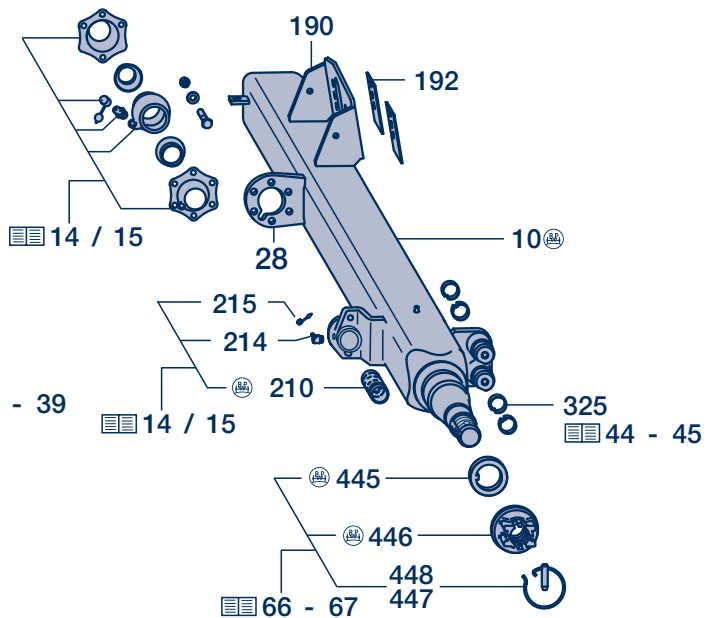
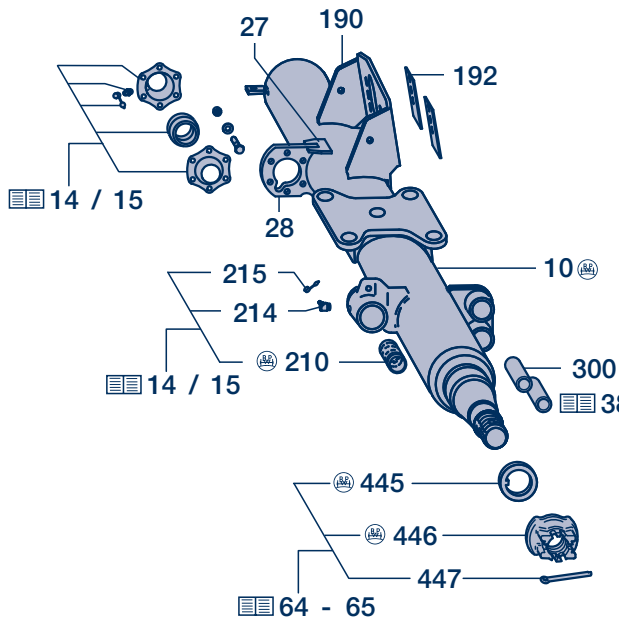

Axle series H.. / R..

Axle series K.. / N..

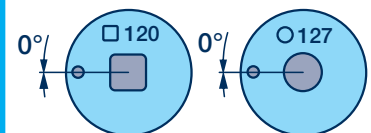
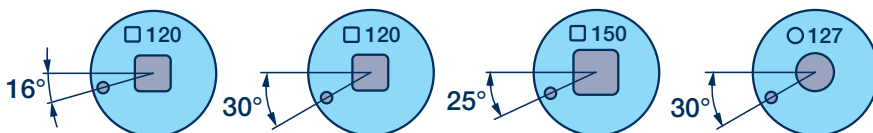

Axle beam 1

Axle beams, booster brackets 1.1

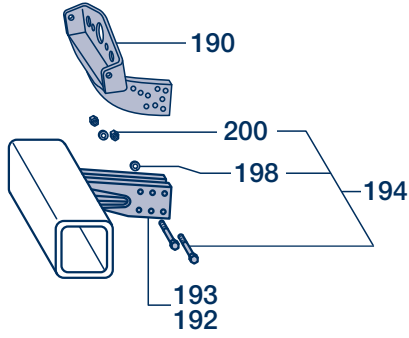
Item	Designation	BPW Code no. Dimension		
		H.. / R..	K..	N..
10	Axle beam assembly (incl. item 27, 28, 190-194 210-215, 220-230, 300, 445-447)	When ordering axle beam assembly, please state axle type and BPW code-no. (axle type plate).		
27	Plate	-	-	03.287.43.03.0 Brake 30..-1
28	Plate	03.285.55.71.0 □ 120 16°	03.285.54.12.0 □ 120	03.285.54.16.0 □ 120
		03.285.55.22.0 □ 120 30°	03.285.56.18.0 ○ 127	03.285.55.19.0 ○ 127
		03.285.55.48.0 * □ 120 30°		
		03.285.55.21.0 □ 150 25°		
	* flattened	03.285.55.23.0 ○ 127 30°		
Booster brackets welded on				
190	Booster bracket (standard) ¹⁾	03.182.35.78.0 □ 120 16°	03.182.35.42.0 □ 120	03.182.35.80.0 □ 120
		03.182.34.77.0 □ 120 30°	03.182.34.65.0 ○ 127	03.182.34.65.0 ○ 127
		03.182.34.77.0 □ 150 25°	03.182.34.95.0 ○ 127 15°	
		03.182.34.58.0 ○ 127		
192	Plate (Reinforcement plate for spring brakes)	03.281.54.10.0		
¹⁾ for further types refer pages 24 - 26.				
Adjustable booster brackets				
190	Booster bracket	05.182.34.23.0		
192	Shaped plate	03.165.56.01.0 □ 120 / 150		
193	Shaped plate	03.165.56.02.0 □ 120 / 150		
		03.165.56.05.0 ○ 127		
		03.165.56.06.0 ○ 127		
194	Bolt assembly (incl. item 198, 200)	05.865.01.04.0 M 12 x 40		
198	Spring washer	02.5601.12.90 A 12 / 128		
200	Hexagon nut	02.5202.16.80 M 12 / 934		
Adjustable booster brackets are not included with axle beam assembly 09.....				
		H.. / R..	K..	N..
210	Bush	03.112.44.34.0	Ø 42/46x73	03.112.44.34.0 Ø 42/46x73
214	Grease nipple e.g. SN 4222	02.6802.03.50	AM 10 x 1	02.6802.03.50 AM 10 x 1
		02.6802.06.50	BM 10 x 1	02.6802.06.50 BM 10 x 1
		02.6850.12.50	BM 10 x 1/67°	-
215	Cap	02.3505.20.00		02.3505.20.00
300	Bush (for brake ...-1 / -2)	03.112.33.08.0	Ø 36/40x60	03.112.33.08.0 Ø 36/40x60

2 Brake camshafts, brake camshaft bearings

General

BPW Brake camshafts and bearings

Optimized sealing and improved support for brake camshaft bearings on BPW drum brake axles

As from **October 2000**, an innovative sintered bush in conjunction with a new integrated sealing system will mean double life expectancy for bearing and brake camshaft units.

Advantages:

- ⊙ Double life expectancy for brake camshaft and bearing units
- ⊙ Increased reliability of operation
- ⊙ Integrated sealing system
- ⊙ Compact design
- ⊙ Easy, secure installation
- ⊙ For use with all BPW drum brake axles

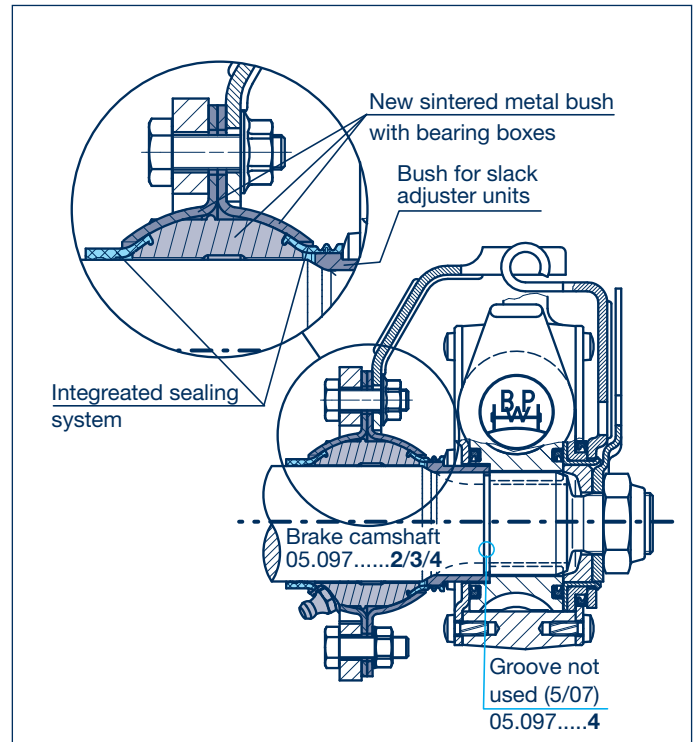

Slack adjuster system on the brake camshaft - 4 / 91

Contact on shoulder of brake camshaft (1)

5 / 91 - 10 / 00

Contact on circlip (2)

10 / 00 -

Contact on the brake camshaft sleeve (3)

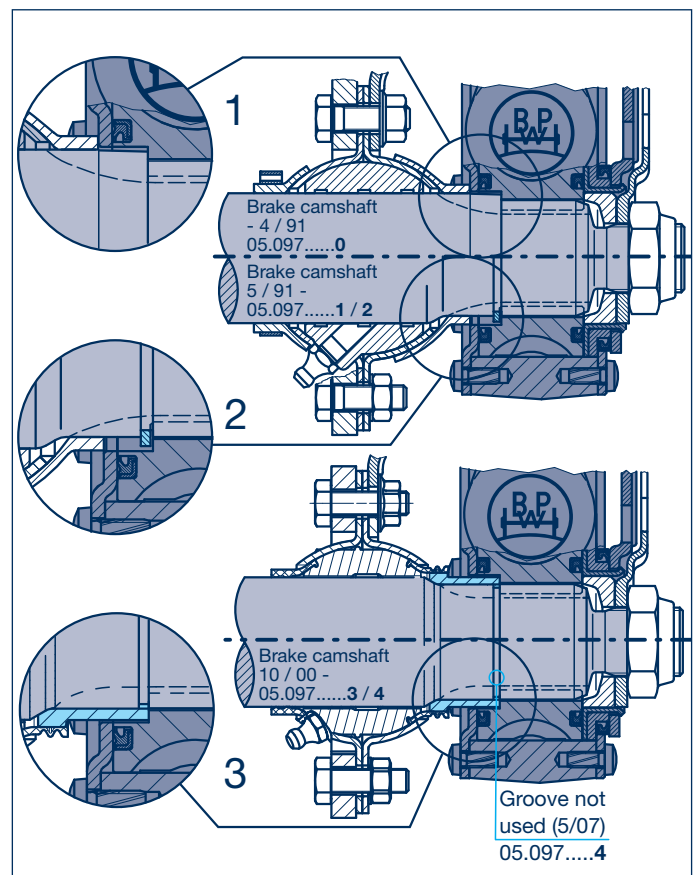

Brake camshafts, brake camshaft bearings 2

General

Optimized brake camshaft bush and additional 'O'-Ring

From February 2002, BPW drum brake axles with support bearings for brake sizes SN 300, SN 360, and SN 420 will be fitted with a further development of our camshaft bearing on the brake anchor plate side.

Features:

- ⊙ The layout of the lubricating grooves inside the brass bush **03.112.44.34.0** has been improved. The bush has a machined annular groove on the outside. The previous code number for the bush will apply.
- ⊙ The brake camshaft has an additional groove in the bearing seat on the cam side in order to accommodate the 'O'-ring **02.5677.37.42** (Ø 37 x 2.6 (black)). The code number of the brake camshaft has changed. The last digit of the former number (**1, 2** or **3**) is changed to indicate version **4**.

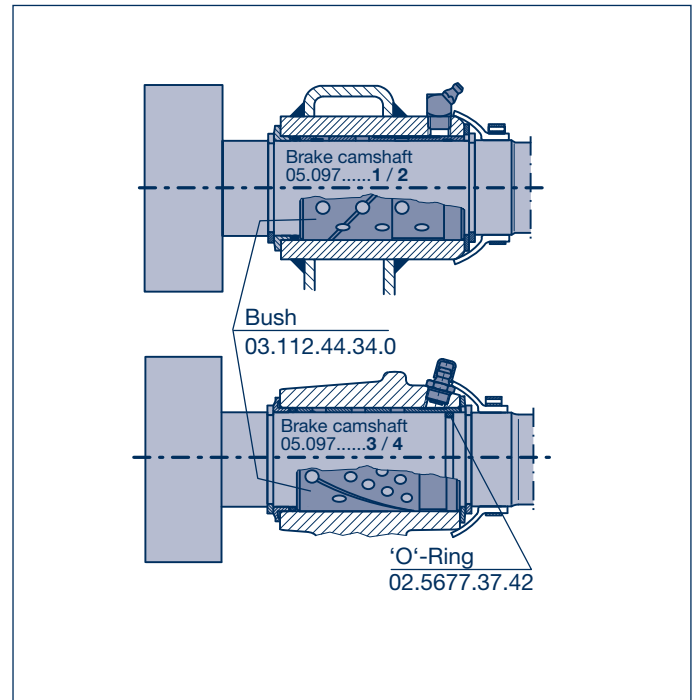

Modified inner camshaft support bearing fixing bolts on drum brake axles

From week **23/2003** onwards, the inner camshaft support bearing fixing bolts will be modified on series production drum brake axles. The self-cutting bolts **02.5071.23.00** used as standard up to now will be replaced by hexagon bolts **02.5025.30.82** with nuts.

In automatic slack adjusters (AGS), the shaped plate for the slack adjuster support is secured using these bolts in conjunction with the Tensilock lock nuts (BPW no. **02.5273.32.82**).

Support bearing is also assembled using screws in connection with spring washers and standard hexagon nuts (BPW no. compl. 05.865.00.02.0), from 2014 only hexagon screws with lock nuts (BPW no. 02.5273.48.82) are used, the BPW no. of screw part groups does not change.

The bolts are fitted towards the centre of the axle.

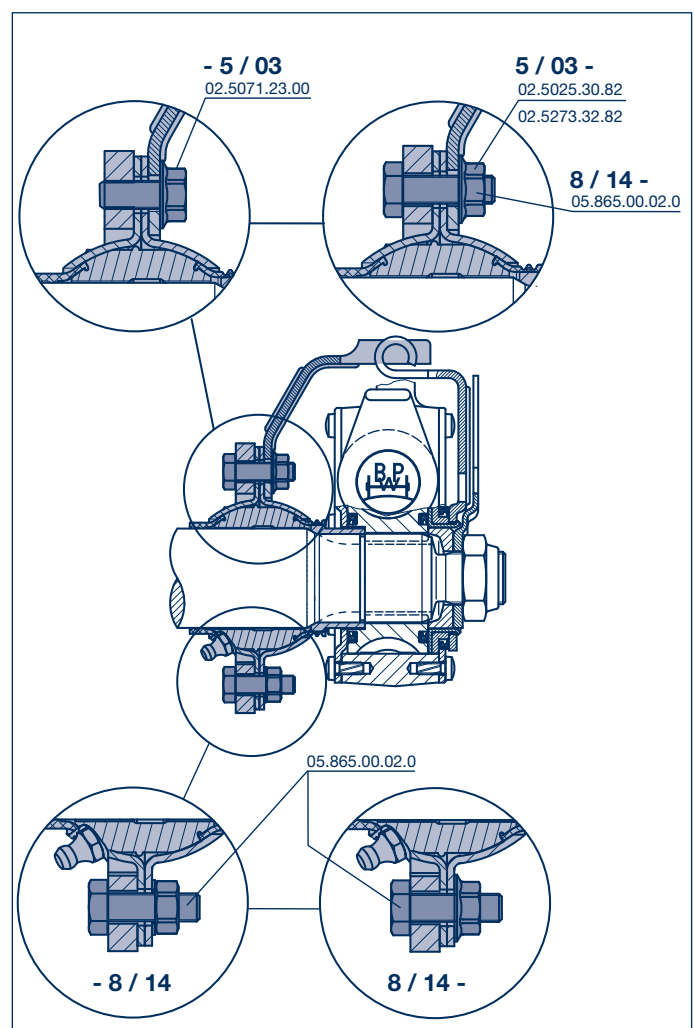

2 Brake camshafts, brake camshaft bearings

2.1 Brake camshafts for axle series H.. / R.. + K..

H
K

Item	Designation (Remark)	BPW Code no.			
240	Brake camshaft, left	05.097.....4			
241	Brake camshaft, right	05.097.....4			
H.. / R.. SN 42.. ---.7xx---					
K.. SN 3620 ---.546. / 552---					
	A	L	B	left	right
	285.5	404	316	05.097.05.01.4	05.097.05.02.4
	299.5	418	330	03.4	04.4
	311.5	430	342	05.4	06.4
	322.5	441	353	07.4	08.4
	337.5	456	368	35.4	36.4
	361.5	480	392	09.4	10.4
	397.5	516	428	11.4	12.4
	422.5	541	453	13.4	14.4
	431.5	550	462	15.4	16.4
	457.5	576	488	45.4	46.4
	469.5	588	500	17.4	18.4
	484.5	603	515	47.4	48.4
	499.5	618	530	19.4	20.4
	509.5	628	540	21.4	22.4
	522.5	641	563	23.4	24.4
	547.5	666	578	25.4	26.4
	557.5	676	588	39.4	40.4
	577.5	696	608	27.4	28.4
	615.5	734	646	29.4	30.4
	634.5	753	665	37.4	38.4
	649.5	768	680	57.4	58.4
	699.5	818	730	49.4	50.4
	741.5	860	772	31.4	32.4
	751.5	870	782	55.4	56.4
K.. SN 3616 ---.542. / 551---					
	A	L	B	left	right
	172.5	291	203	05.097.09.07.4	05.097.09.08.4
	649.5	768	680	13.4	14.4
	699.5	818	730	15.4	16.4
	751.5	870	782	09.4	10.4
	866.5	985	897	17.4	18.4

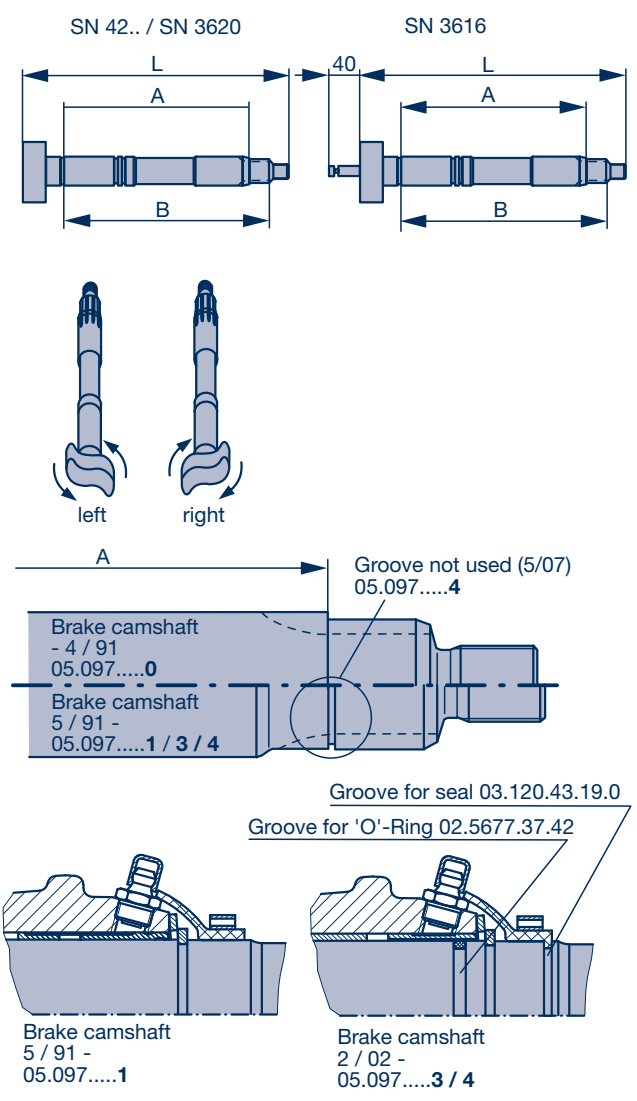

Brake camshafts with last digit of code number **0** (until 4/91), **1** (until 12/95), **2** (until 4/02) and **3** (until 5/07) will be replaced with brake camshafts with last digit **4**.
Note modified assembly parts.

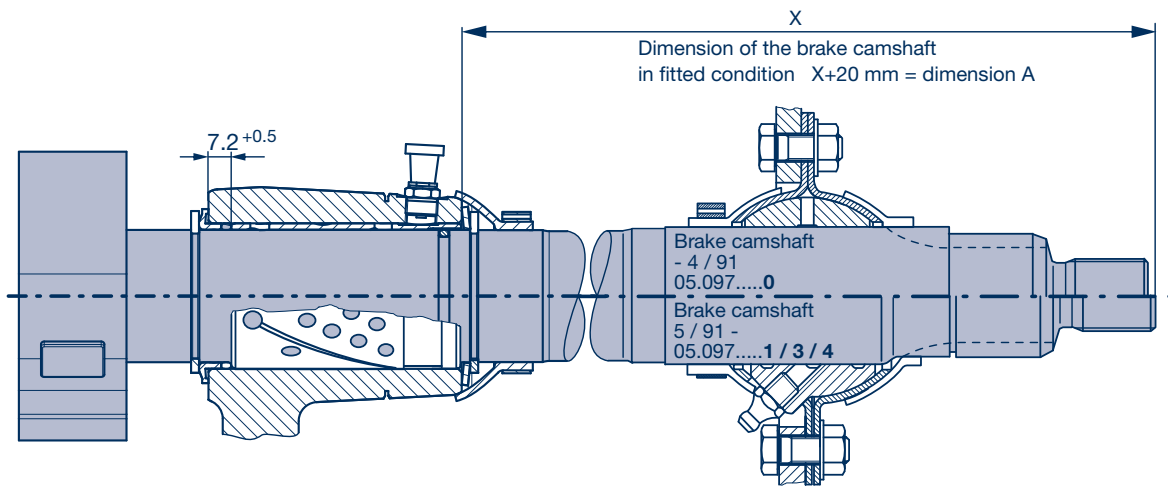

Brake camshafts, brake camshaft bearings 2

Brake camshafts for axle series N.. 2.1

Item	Designation (Remark)	BPW Code no.																																																																																																																																							
240	Brake camshaft, left	05.097.60....4																																																																																																																																							
241	Brake camshaft, right	05.097.60....4																																																																																																																																							
<table border="1"> <thead> <tr> <th>N..</th> <th>SN 30..</th> <th>---.50x---</th> <th>---.58x---</th> <th>---.59x---</th> </tr> </thead> <tbody> <tr> <th>A</th> <th>L</th> <th>B</th> <th>left</th> <th>right</th> </tr> <tr> <td>182.5</td> <td>307 (333)</td> <td>213</td> <td>05.097.60.27.4</td> <td>05.097.60.28.4</td> </tr> <tr> <td>212.5</td> <td>337 (363)</td> <td>243</td> <td>19.4</td> <td>20.4</td> </tr> <tr> <td>311.5</td> <td>436 (462)</td> <td>342</td> <td>39.4</td> <td>40.4</td> </tr> <tr> <td>337.5</td> <td>462 (488)</td> <td>368</td> <td>11.4</td> <td>12.4</td> </tr> <tr> <td>380.5</td> <td>505 (531)</td> <td>411</td> <td>43.4</td> <td>44.4</td> </tr> <tr> <td>395.5</td> <td>520 (546)</td> <td>426</td> <td>01.4</td> <td>02.4</td> </tr> <tr> <td>422.5</td> <td>547 (573)</td> <td>453</td> <td>15.4</td> <td>16.4</td> </tr> <tr> <td>457.5</td> <td>582 (608)</td> <td>488</td> <td>13.4</td> <td>14.4</td> </tr> <tr> <td>469.5</td> <td>594 (620)</td> <td>500</td> <td>03.4</td> <td>04.4</td> </tr> <tr> <td>509.5</td> <td>634 (660)</td> <td>540</td> <td>09.4</td> <td>10.4</td> </tr> <tr> <td>522.5</td> <td>647 (673)</td> <td>553</td> <td>07.4</td> <td>08.4</td> </tr> <tr> <td>548.5</td> <td>673 (699)</td> <td>579</td> <td>23.4</td> <td>24.4</td> </tr> <tr> <td>557.5</td> <td>682 (708)</td> <td>588</td> <td>05.4</td> <td>06.4</td> </tr> <tr> <td>567.5</td> <td>692 (718)</td> <td>598</td> <td>49.4</td> <td>50.4</td> </tr> <tr> <td>582.5</td> <td>707 (733)</td> <td>613</td> <td>45.4</td> <td>46.4</td> </tr> <tr> <td>598.5</td> <td>723 (749)</td> <td>629</td> <td>41.4</td> <td>42.4</td> </tr> <tr> <td>615.5</td> <td>740 (766)</td> <td>646</td> <td>17.4</td> <td>18.4</td> </tr> <tr> <td>638.5</td> <td>763 (789)</td> <td>669</td> <td>47.4</td> <td>48.4</td> </tr> <tr> <td>648.5</td> <td>773 (799)</td> <td>679</td> <td>25.4</td> <td>26.4</td> </tr> <tr> <td>675.5</td> <td>800 (826)</td> <td>706</td> <td>21.4</td> <td>22.4</td> </tr> <tr> <td>698.5</td> <td>823 (849)</td> <td>729</td> <td>37.4</td> <td>38.4</td> </tr> <tr> <td>723.5</td> <td>848 (874)</td> <td>754</td> <td>31.4</td> <td>32.4</td> </tr> <tr> <td>748.5</td> <td>873 (899)</td> <td>779</td> <td>33.4</td> <td>34.4</td> </tr> <tr> <td>798.5</td> <td>923 (949)</td> <td>829</td> <td>35.4</td> <td>36.4</td> </tr> <tr> <td>848.5</td> <td>973 (999)</td> <td>879</td> <td>29.4</td> <td>30.4</td> </tr> </tbody> </table>			N..	SN 30..	---.50x---	---.58x---	---.59x---	A	L	B	left	right	182.5	307 (333)	213	05.097.60.27.4	05.097.60.28.4	212.5	337 (363)	243	19.4	20.4	311.5	436 (462)	342	39.4	40.4	337.5	462 (488)	368	11.4	12.4	380.5	505 (531)	411	43.4	44.4	395.5	520 (546)	426	01.4	02.4	422.5	547 (573)	453	15.4	16.4	457.5	582 (608)	488	13.4	14.4	469.5	594 (620)	500	03.4	04.4	509.5	634 (660)	540	09.4	10.4	522.5	647 (673)	553	07.4	08.4	548.5	673 (699)	579	23.4	24.4	557.5	682 (708)	588	05.4	06.4	567.5	692 (718)	598	49.4	50.4	582.5	707 (733)	613	45.4	46.4	598.5	723 (749)	629	41.4	42.4	615.5	740 (766)	646	17.4	18.4	638.5	763 (789)	669	47.4	48.4	648.5	773 (799)	679	25.4	26.4	675.5	800 (826)	706	21.4	22.4	698.5	823 (849)	729	37.4	38.4	723.5	848 (874)	754	31.4	32.4	748.5	873 (899)	779	33.4	34.4	798.5	923 (949)	829	35.4	36.4	848.5	973 (999)	879	29.4	30.4
N..	SN 30..	---.50x---	---.58x---	---.59x---																																																																																																																																					
A	L	B	left	right																																																																																																																																					
182.5	307 (333)	213	05.097.60.27.4	05.097.60.28.4																																																																																																																																					
212.5	337 (363)	243	19.4	20.4																																																																																																																																					
311.5	436 (462)	342	39.4	40.4																																																																																																																																					
337.5	462 (488)	368	11.4	12.4																																																																																																																																					
380.5	505 (531)	411	43.4	44.4																																																																																																																																					
395.5	520 (546)	426	01.4	02.4																																																																																																																																					
422.5	547 (573)	453	15.4	16.4																																																																																																																																					
457.5	582 (608)	488	13.4	14.4																																																																																																																																					
469.5	594 (620)	500	03.4	04.4																																																																																																																																					
509.5	634 (660)	540	09.4	10.4																																																																																																																																					
522.5	647 (673)	553	07.4	08.4																																																																																																																																					
548.5	673 (699)	579	23.4	24.4																																																																																																																																					
557.5	682 (708)	588	05.4	06.4																																																																																																																																					
567.5	692 (718)	598	49.4	50.4																																																																																																																																					
582.5	707 (733)	613	45.4	46.4																																																																																																																																					
598.5	723 (749)	629	41.4	42.4																																																																																																																																					
615.5	740 (766)	646	17.4	18.4																																																																																																																																					
638.5	763 (789)	669	47.4	48.4																																																																																																																																					
648.5	773 (799)	679	25.4	26.4																																																																																																																																					
675.5	800 (826)	706	21.4	22.4																																																																																																																																					
698.5	823 (849)	729	37.4	38.4																																																																																																																																					
723.5	848 (874)	754	31.4	32.4																																																																																																																																					
748.5	873 (899)	779	33.4	34.4																																																																																																																																					
798.5	923 (949)	829	35.4	36.4																																																																																																																																					
848.5	973 (999)	879	29.4	30.4																																																																																																																																					
<p>Brake camshafts with last digit of code number 0 (until 4/91), 1 (until 12/95), 2 (until 4/02) and 3 (until 5/07) will be replaced with brake camshafts with last digit 4. Note modified assembly parts.</p>																																																																																																																																									

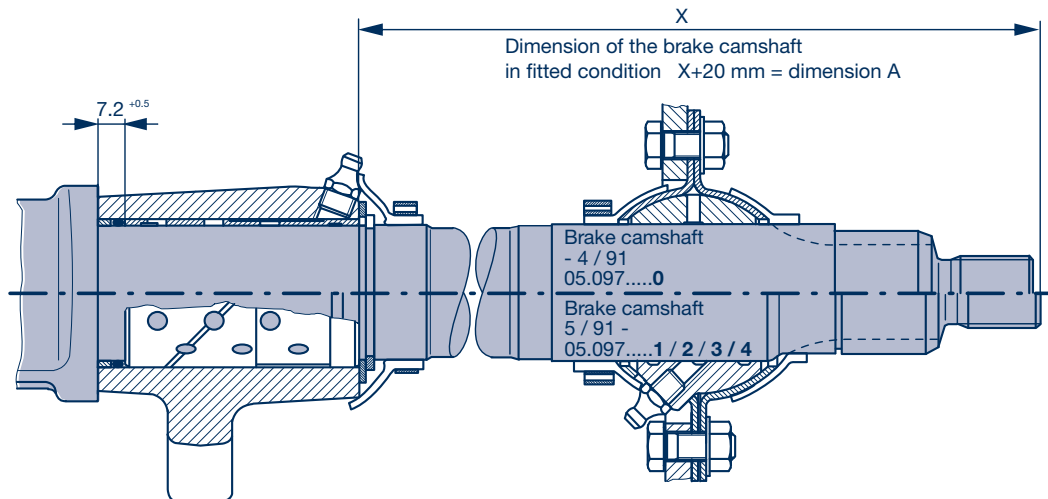
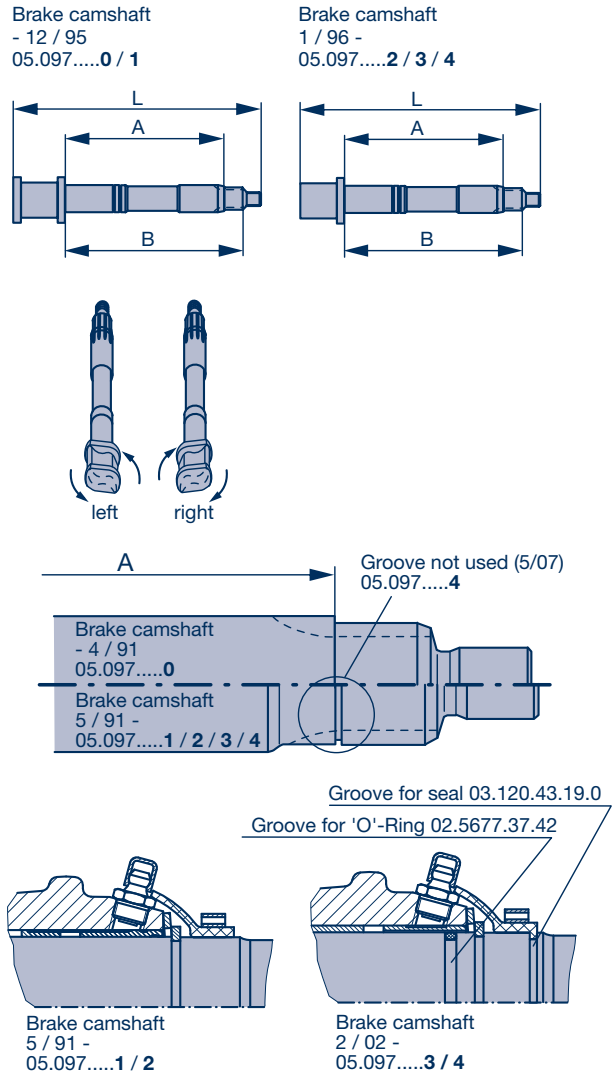

N

2 Brake camshafts, brake camshaft bearings

2.2 Brake camshaft bearings

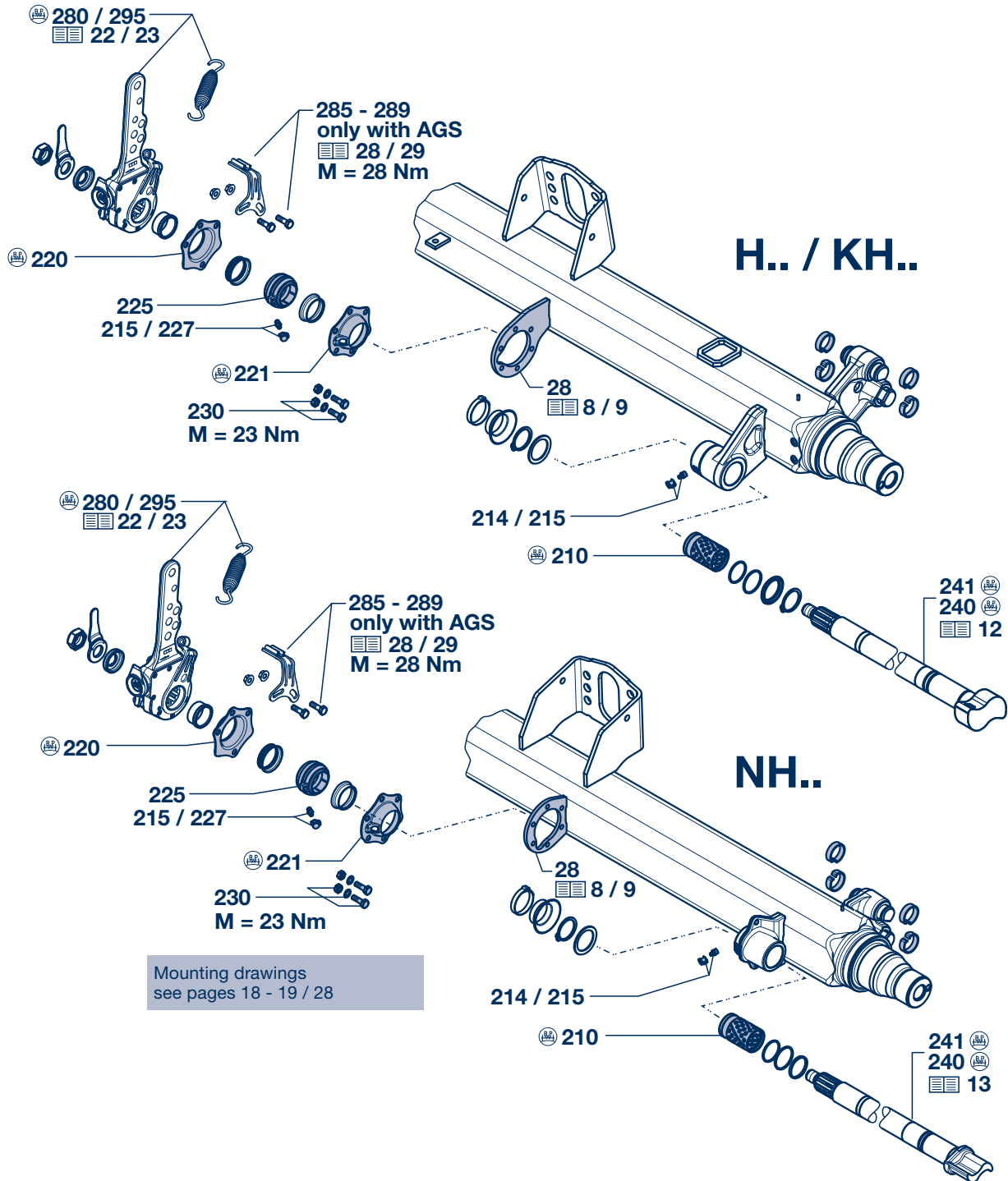

Brake camshafts, brake camshaft bearings 2

Brake camshaft bearings 2.2

Item	Designation (Remark)	BPW Code no. Dimension		
		H.. / R..	K..	N..
28	Plate	see page 9		
208	Repair kit low-maintenance brake camshaft bearing (item 210 - 214, 220 - 230, 245, 270, 272, 274, 288, 289)	09.801.02.13.1	for 1 axle side Brake camshaft with last digit 0 - 4	
		09.801.06.09.1	for 1 axle Brake camshaft with last digit 0 - 4	
210	Bush	03.112.44.34.0	Ø 42 / 46 x 73	
214	Grease nipple e.g. SN 4222	02.6802.03.50	AM 10 x 1 / 0°	
		02.6802.06.50	BM 10 x 1 / 45°	
		02.6850.12.50	BM 10 x 1 / 67°	
215	Cap	02.3505.20.00		
		<p>Low-maintenance brake camshaft bearing Bearing box attachment with locking bolts 1 / 93 - 10 / 00 Fig. G, page 19</p>		
220	Bearing box	03.229.02.16.1	4 x Ø 10	
221	Bearing box (for grease nipple)	03.229.02.17.0	6 x Ø 10	
225	Spherical bearing	03.113.14.03.0	Ø 42 / 62 x 38	
227	Grease nipple	02.6802.14.50	AM 8 x 1 / 8.5 lg.	
230	Locking bolt	02.5071.23.00	M 8 x 20 (4x)	
		<p>Low-maintenance brake camshaft bearing Bearing box attachment with hexagon bolts 10 / 00 - 8 / 14 Fig. H, page 19</p>		
		<p>Low-maintenance brake camshaft bearing Bearing box attachment with hexagon bolts 8 / 14 - Fig. H, page 19</p>		
219	Repair kit support bearing (item 220 - 230, 260, 271, 272)	09.801.02.15.1	for 1 axle side	
220	Bearing box	03.229.02.18.0	4 x Ø 10	
221	Bearing box (for grease nipple)	03.229.02.19.0	6 x Ø 10	
225	Spherical bearing	03.113.14.04.0	Ø 42 / 60 x 38	
227	Grease nipple	02.6850.17.00	BM 8 x 1 / 71412	
230	Bolt assembly (incl. item 231, 232)	05.865.00.02.0	M 8 x 25	
231	Lock washer	02.5403.08.92	B 8 / 137	
232	Hexagon nut	02.5202.12.82	M 8 / 934	
232	Lock nut	-	02.5273.48.82 M 8	

When converting to low-maintenance brake camshaft bearings, low-maintenance automatic slack adjusters type ECO-Master should be used.

Use only BPW special grease ECO-Li 91 or ECO-Li^{Plus} for low-maintenance brake camshaft bearings.

**No longer available.
 Retrofit to new low-maintenance
 brake camshaft bearing.
 Retrofit kit 09.801.02.15-1**

H

K

N

2 Brake camshafts, brake camshaft bearings

2.2 Brake camshaft bearings

H
K
N

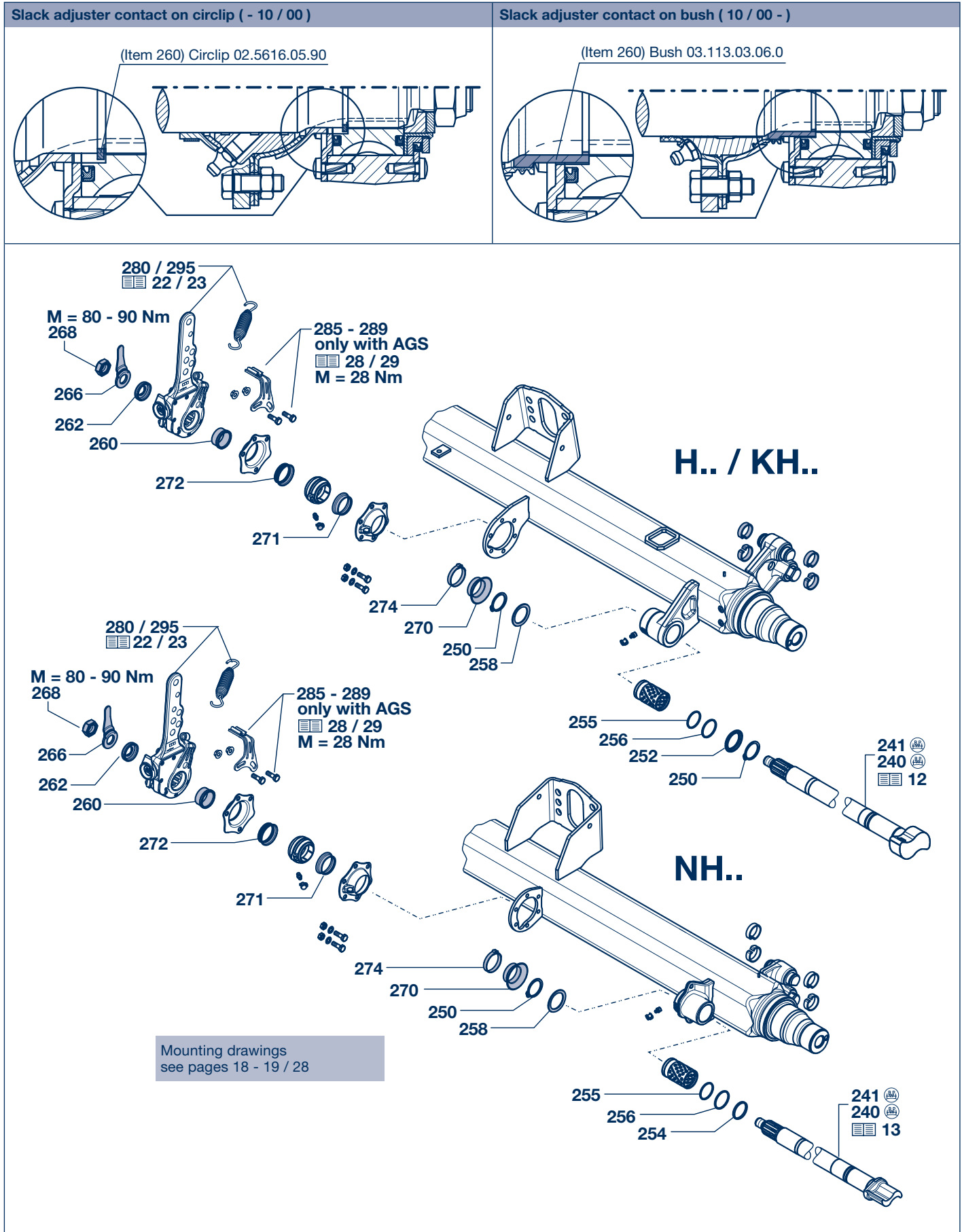

Brake camshafts, brake camshaft bearings 2

Brake camshaft bearings 2.2

Item	Designation (Remark)	BPW Code no. Dimension					
		H.. / R..	K..	N..	H.. / R..	K..	N..
		Brake camshaft with last digit 0 / 1 / 2 - 2 / 02 Fig. A / D / G, page 18 / 19			Brake camshaft with last digit 3 / 4 2 / 02 - Fig. B / E / C / F / H, page 18 / 19		
245	Assembly kit (item 250 - 262, 268, 270, 274)	09.801.00.14.2 for 1 axle side			09.801.00.43.1 for 1 axle side		
250	Circlip	02.5676.01.00	A 42 x 2.5 (N.. 2x)		02.5676.01.00	A 42 x 2.5 (N.. 2x)	
252	Ring (Thrust ring)	03.310.12.24.0 ¹⁾	Ø 42 / 46 / 55 x 7		03.310.12.24.0 ¹⁾	Ø 42 / 46 / 55 x 7	
254	Ring	03.310.81.02.0	Ø 42 / 46 x 4 (only N..)		03.310.81.02.0	Ø 42 / 46 x 4 (only N..)	
255	'O'-Ring	-			02.5677.37.42	Ø 37 x 2.6 (black)	
256	'O'-Ring	02.5679.23.00	Ø 40 x 2.5 (green)		02.5679.23.00	Ø 40 x 2.5 (green)	
258	Seal	03.120.42.02.0	Ø 42 / 56 x 2		03.120.42.02.0	Ø 42 / 56 x 2	
260	Circlip (- 10 / 00)	02.5616.05.90 ²⁾	Ø 37 / 41 x 2		-		
260	Bush (10 / 00 -)	03.113.03.06.0	Ø 37.4 / 45 x 21.3		03.113.03.06.0	Ø 37.4 / 45 x 21.3	
262	Washer	03.320.11.16.1	Ø 22.5 / 42 x 10.5		03.320.11.16.1	Ø 22.5 / 42 x 10.5	
266	Lever (Brake lining wear indicator)	03.190.14.07.1	85 mm		03.190.14.07.1	85 mm	
		03.190.14.08.1	60 mm		03.190.14.08.1	60 mm	
268	Hexagon nut	03.260.14.08.0	M 22 x 1.5 / SW 32		03.260.14.08.0	M 22 x 1.5 / SW 32	
		Low-maintenance brake camshaft bearing					
		Brake camshaft with last digit 1 and 2 1 / 93 - 10 / 00 Fig. A / B / G, page 18 / 19		Brake camshaft with last digit 3 / 4 10 / 00 - Fig. A / B / H, page 18 / 19		Brake camshaft with last digit 3 / 4 08 / 14 - Fig. C / F / H, page 18 / 19	
270	Seal	03.120.43.14.0	Ø 41 x 25		03.120.43.14.0	Ø 41 x 25	
271	Seal	03.120.43.12.0	Ø 41 x 20		03.120.42.09.0	Ø 42 x 15	
272	Seal	03.120.43.10.0	Ø 34 x 26		03.120.42.08.0	Ø 45 x 13.5	
274	Circlip	03.350.30.02.0	Ø 49 x 9		03.350.30.02.0	Ø 49 x 9	

¹⁾ Replacement for rings 03.310.32.09.0 and 03.310.81.02.0, only for H.. / K..

²⁾ With brake camshaft having 1 or 2 as last digit

 When converting to low-maintenance brake camshaft bearings, low-maintenance automatic slack adjusters type ECO-Master should be used.

 Use only BPW special grease ECO-Li 91 or ECO-Li^{Plus} for low-maintenance brake camshaft bearings.

2 Brake camshafts, brake camshaft bearings

2.2 Brake camshaft bearings

Mounting drawings

H
K
N

H.. / R..	H.. / R..	K..
A Low-maintenance brake camshaft bearing, - 2 / 02	B Low-maintenance brake camshaft bearing, 2 / 02 - New brake camshaft 05.097.05(09)....3/4, 2 / 02 -	
H.. / R..	K..	
C Low-maintenance brake camshaft bearing, 8 / 14 - Brake camshaft 05.097.05(09)....4	D Low-maintenance brake camshaft bearing, - 2 / 02	
N..		
E Low-maintenance brake camshaft bearing, 2 / 02 - New brake camshaft 05.097.60....3/4, 2 / 02 -	F Low-maintenance brake camshaft bearing, 8 / 14 - Brake camshaft 05.097.60....4	

Brake camshafts, brake camshaft bearings 2

Brake camshaft bearings 2.2

Mounting drawings

H.. / R..	K..	N..	H.. / R..	K..	N..
G Low-maintenance brake camshaft bearing, 1 / 93 - 10 / 00			H Low-maintenance brake camshaft bearing, 10 / 00 -		
I Conversion to low-maintenance brake camshaft bearing Support plates without a lubrication nipple recess Brake camshaft 05.097.05(09)....3/4, 5 / 02 - Brake camshaft 05.097.60....3/4, 5 / 02 -					

H

K

N

3 Slack adjusters

General

BPW Slack adjusters

The required brake cylinder stroke increases as the brake lining thickness reduces. The slack adjuster makes up for this change and keeps the brake cylinder stroke in the optimum range at all times.

In most countries, fitting automatic slack adjusters is a statutory requirement.

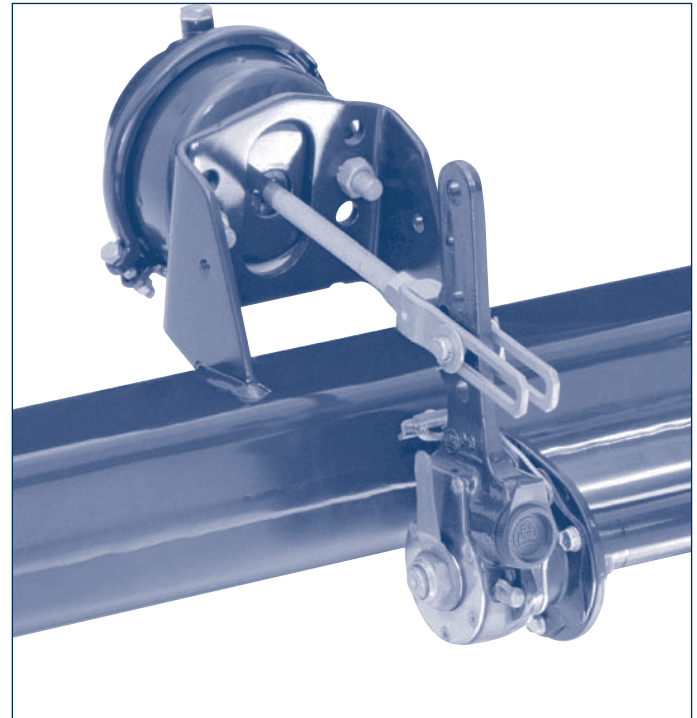

The principle of automatic adjustment

Brake linings and brake drums are parts subject to wear. As the thickness of the material is reduced, the brake cylinder stroke increases, meaning that the brake camshaft has to rotate further.

In this case, the automatic function of the ECO-Master automatic slack adjuster provides the necessary adjustment.

As a result, the brake cylinder stroke is always kept within the same, optimum range.

The adjustment stroke is designed so that there is always sufficient air gap even at higher levels of elasticity and given thermal expansion of the adjacent components (e.g. the brake drum).

Levers with different shapes and crank values are available depending on the particular installation conditions.

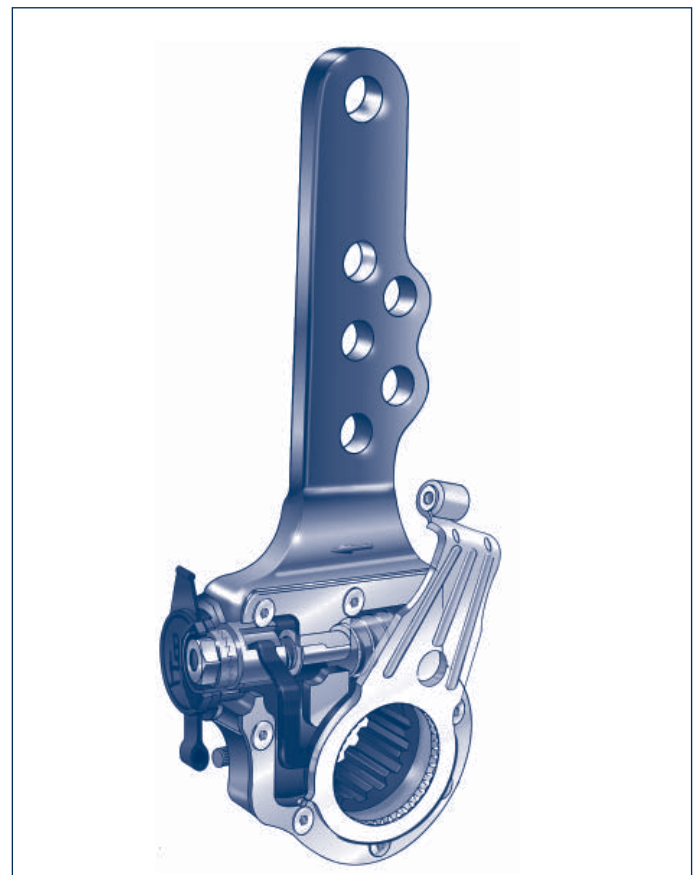

Slack adjusters 3

General

Determining replacement slack adjusters

The BPW code number is punched into the cover plate of the slack adjuster.

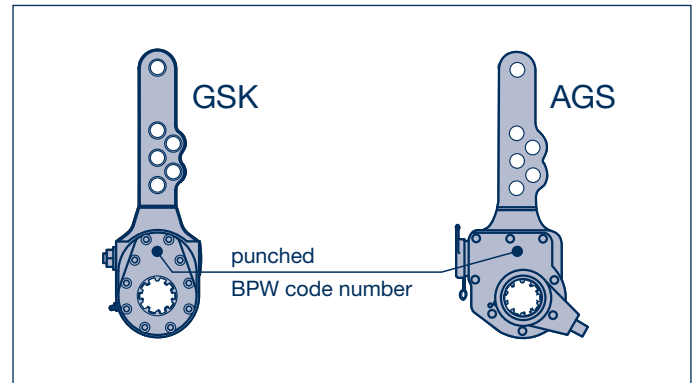

If there is no BPW code number or it is not legible, the slack adjuster can be identified on the basis of the shape and dimensions.

1. **Automatic (AGS) or manual slack adjuster (GSK)**
2. **Lever length (HL)**
3. **Crank value (X)**
4. **Lever position (β)**
5. **Position of fixed point holder with AGS (α)**

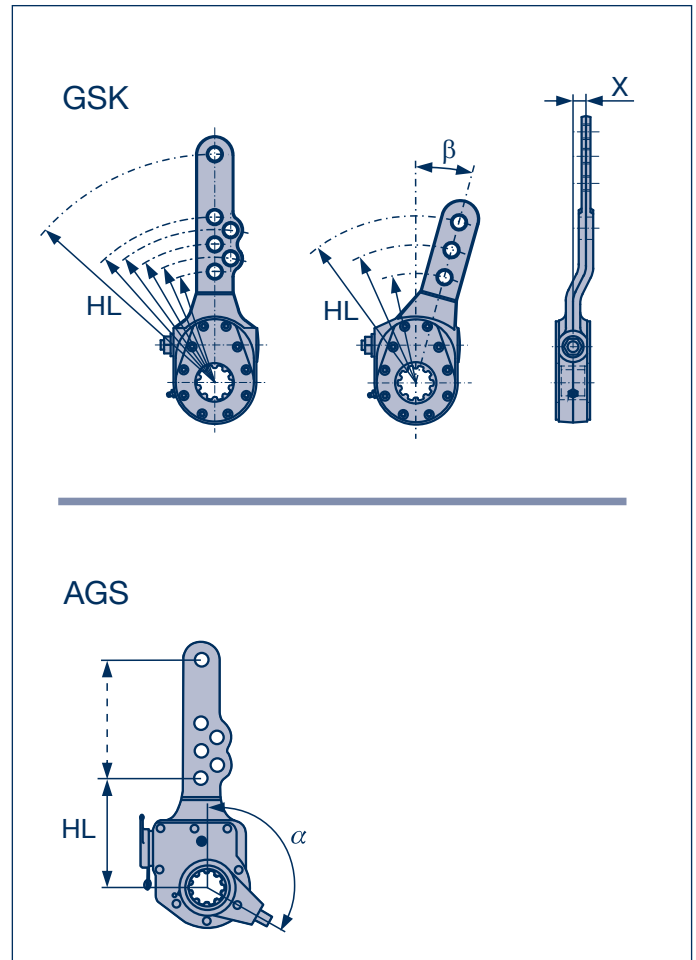

Return springs

When fitting BPW brake cylinders with round-hole yokes and with a lever length of more than 100 mm, the return spring does not have to be fitted.

3 Slack adjusters

3.1 Manual slack adjusters (GSK), return springs

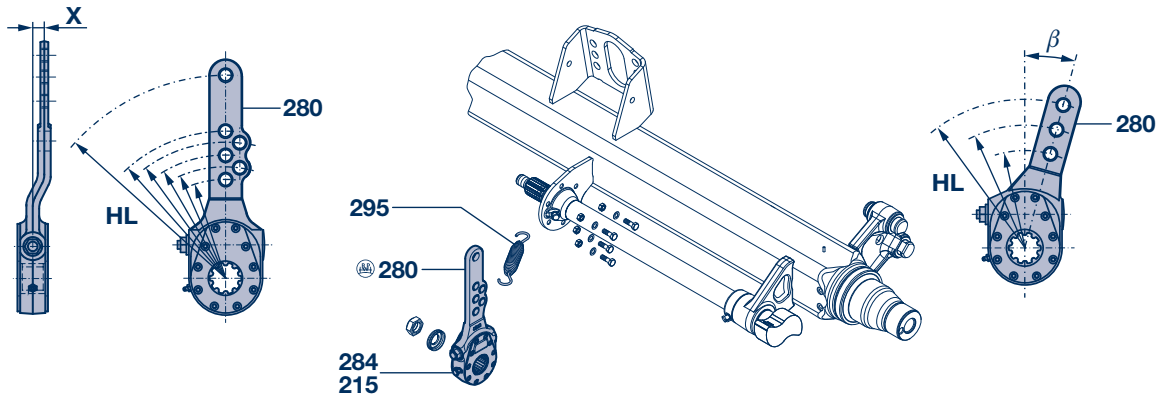

Item	Designation	BPW Code no.	Dimension			
280 / 281	Slack adjuster (GSK) incl. item 215, 284	GSK (manual)				
		H.. / R..	K..	N..		
	HL 120 / 150 / 180	05.174.52.34.0 3 holes	05.174.52.34.0 3 holes	05.174.52.34.0 3 holes		
			05.174.65.20.0 3 holes / β 15°	05.174.65.20.0 3 holes / β 15°		
	HL 230 / 260 / 290 / X=14	05.174.58.13.0 3 holes left	-	-		
		05.174.58.14.0 3 holes right	-	-		
	HL 150 / 150 / 180 / 250	05.174.52.61.0 4 holes	05.174.52.61.0 4 holes	05.174.52.43.0 4 holes / β 15°		
		-	05.174.52.43.0 4 holes / β 15°	-		
	HL 120 / 150 / 195 / 250	-	-	05.174.65.14.0 4 holes / β 15°		
	HL 120 / 135 / 150 / 165 / 180	05.174.65.22.0 5 holes	05.174.65.22.0 5 holes	-		
	HL 120 / 135 / 150 / 165 / 180 / 250	05.174.65.13.0 6 holes	05.174.65.13.0 6 holes	05.174.65.13.0 6 holes		
215	Cap	02.3505.20.00				
284	Grease nipple	02.6850.01.02 AS 8 x 1 / 0°				

Item	Designation	BPW Code no.	Dimension			
		H.. / R..	K..	N..		
295	Return spring	03.397.26.04.0 Ø 24/2.8x69	03.397.26.04.0 Ø 24/2.8x69	03.397.26.08.0 Ø 21/2.8x84		
		03.397.26.09.0 Ø 24/2.8x72	03.397.26.08.0 Ø 21/2.8x84	03.397.26.06.0 Ø 24/2.8x89		
		03.397.26.08.0 Ø 24/2.8x84	03.397.26.06.0 Ø 24/2.8x89	05.397.28.01.0 Ø 31/2.8x120		
		03.397.26.06.0 Ø 24/2.8x89	05.397.28.01.0 Ø 31/2.8x120	05.397.26.03.0 Ø 26/2.8x148		
		05.397.28.01.0 Ø 31/2.8x120	05.397.26.03.0 Ø 26/2.8x148	05.397.26.02.0 Ø 22.5/2.5x235		
		05.397.26.03.0 Ø 26/2.8x148	05.397.28.02.0 Ø 22.5/2.5x235			
		05.397.26.05.0 Ø 22.5/2.5x185				
		05.397.26.02.0 Ø 22.5/2.5x235				

Slack adjusters 3

Automatic slack adjusters (ECO-Master (AGS)) 3.2

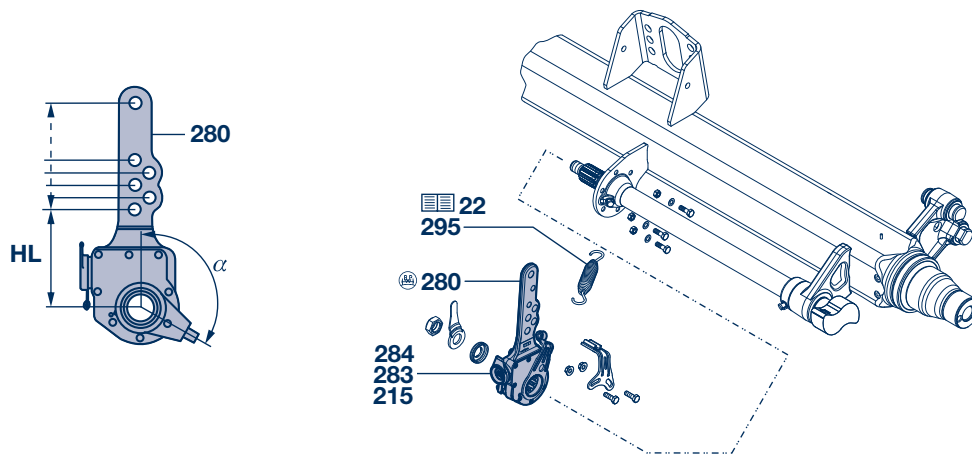

Item	Designation	BPW Code no.	Dimension	
280 / 281	Slack adjuster (ECO-Master) incl. item 215, 283, 284	ECO-Master (autom.) (5 / 91 -)		Slack adjuster kit (item 280, 285 - 289)
		H.. / R..	K..	
	HL 120 / 135 / 150 / 165	05.174.82.67.3	5 holes, $\alpha = 24^\circ$	05.574.83.01.3
		05.174.83.06.3	5 holes, $\alpha = 60^\circ$	05.574.82.68.3
		05.174.82.75.3	5 holes, $\alpha = 60^\circ$	05.574.83.08.3
		05.174.82.22.3	5 holes, $\alpha = 120^\circ$	05.574.82.55.3
		05.174.82.31.3	5 holes, $\alpha = 180^\circ$	05.574.82.67.3
		05.174.88.51.3	5 holes, $\alpha = 210^\circ$	05.574.88.22.3
		05.174.82.32.3	5 holes, $\alpha = 210^\circ$	05.574.82.66.3
	HL 120 / 135 / 150 / 165 / 240	05.174.82.40.3	6 holes, $\alpha = 210^\circ$	05.574.82.45.3
	HL 120 / 135 / 150 / 165 / 250	05.174.82.63.3	6 holes, $\alpha = 24^\circ$	05.574.82.87.3
		05.174.83.17.3 *	6 holes, $\alpha = 24^\circ$	-
		05.174.83.05.3	6 holes, $\alpha = 60^\circ$	05.574.83.07.3
		05.174.82.21.3	6 holes, $\alpha = 120^\circ$	05.574.82.43.3
		05.174.82.24.3	6 holes, $\alpha = 180^\circ$	05.574.82.44.3
		05.174.82.26.3	6 holes, $\alpha = 210^\circ$	05.574.82.65.3
		05.174.83.04.3	6 holes, $\alpha = 210^\circ$	05.574.82.88.3
			N..	
	HL 150 / 165	05.174.89.05.3	3 holes, $\alpha = 180^\circ$	05.574.88.46.3
	HL 120 / 135 / 150 / 165	05.174.82.67.3	5 holes, $\alpha = 24^\circ$	05.574.83.01.3
		05.174.82.31.3	5 holes, $\alpha = 180^\circ$	05.574.82.67.3
		05.174.82.32.3	5 holes, $\alpha = 210^\circ$	05.574.82.66.3
	HL 120 / 135 / 150 / 165	05.174.88.51.3	5 holes, $\alpha = 210^\circ$	05.574.88.22.3
	HL 120 / 135 / 150 / 165 / 250	05.174.82.63.3	6 holes, $\alpha = 24^\circ$	05.574.82.87.3
		05.174.82.24.3	6 holes, $\alpha = 180^\circ$	05.574.82.44.3
		05.174.83.04.3	6 holes, $\alpha = 210^\circ$	05.574.82.88.3
	Further types upon request. * = reinforced			
215	Cap	02.3505.20.00		
283	Cap	03.211.90.15.0		
284	Grease nipple	02.6850.01.02	AS 8 x 1 / 0°	

H

K

N

3 Slack adjusters

3.2 Automatic slack adjusters (ECO-Master (AGS))

H.. / R..

Slack adjusters, booster brackets, return springs

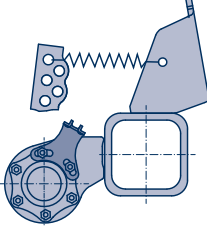
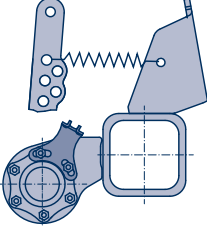
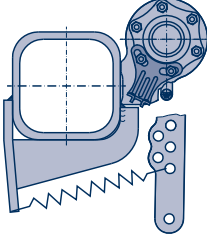
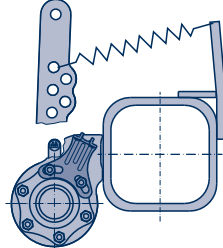
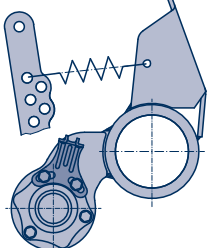
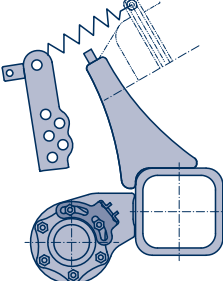
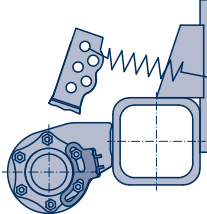
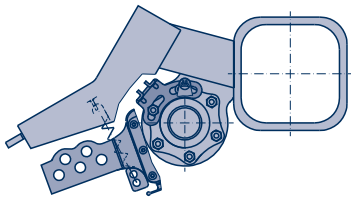
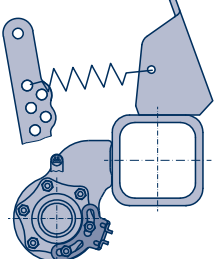
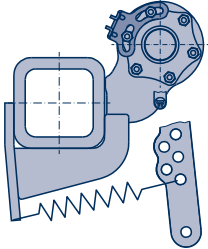
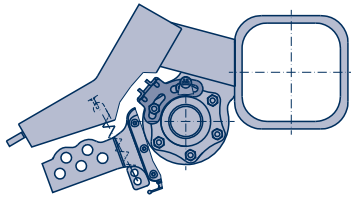
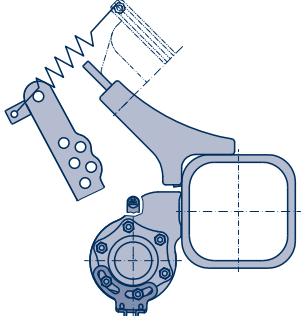
<p>H..</p>  <p>ECO-Master $\alpha=24^\circ$ 05.174.82.63.3 Return spring 05.397.26.03.0 Booster bracket 25°/30° 03.182.34.77.0 16° 03.182.35.78.0 Piston rod 227 mm</p>	<p>H..</p>  <p>ECO-Master $\alpha=24^\circ$ 05.174.82.63.3 Return spring 05.397.26.03.0 Booster bracket 30° 03.182.34.77.0 16° 03.182.35.78.0 Piston rod 227 mm</p>	<p>H..</p>  <p>ECO-Master $\alpha=24^\circ$ 05.174.82.63.3 Return spring 05.397.26.05.0 Booster bracket □ 150 05.182.07.26.0 Piston rod 227 mm</p>
<p>H..</p>  <p>ECO-Master $\alpha=24^\circ$ 05.174.82.63.3 Return spring 05.397.26.05.0 Booster bracket 03.182.07.21.0 Piston rod 227 mm</p>	<p>R..</p>  <p>ECO-Master $\alpha=24^\circ$ 05.174.82.63.3 Return spring 05.397.26.03.0 Booster bracket 03.182.34.58.0 Piston rod 227 mm</p>	<p>H..</p>  <p>ECO-Master $\alpha=60^\circ$ 05.174.83.05.3 Return spring 05.397.26.03.0 Booster bracket 05.182.17.46.0 Piston rod 110 mm</p>
<p>H..</p>  <p>ECO-Master $\alpha=60^\circ$ 05.174.82.75.3 Return spring 05.397.26.03.0 Booster bracket 05.182.16.57.0 Piston rod 180 mm</p>	<p>H..</p>  <p>ECO-Master $\alpha=60^\circ$ 05.174.82.36.3 Return spring 03.397.26.04.0 Booster bracket 25°/30° 05.182.33.15.0 16° L 05.182.45.03.0 16° R 05.182.45.04.0 Piston rod 80 mm</p>	<p>H..</p>  <p>ECO-Master $\alpha=120^\circ$ 05.174.82.21.3 Return spring 05.397.26.03.0 Booster bracket 30° 03.182.34.77.0 16° 03.182.35.78.0 Piston rod 227 mm</p>
<p>H..</p>  <p>ECO-Master $\alpha=120^\circ$ 05.174.82.21.3 Return spring 05.397.26.05.0 Booster bracket □ 120 30° 05.182.07.25.0 □ 150 05.182.07.26.0 Piston rod 227 mm</p>	<p>H..</p>  <p>ECO-Master $\alpha=180^\circ$ 05.174.82.14.3 Return spring 05.397.26.03.0 Booster bracket 05.182.07.37.0 Piston rod 190 mm</p>	<p>H..</p>  <p>ECO-Master $\alpha=210^\circ$ 05.174.82.40.3 Return spring 05.397.26.03.0 Booster bracket 05.182.15.36.0 Piston rod 110 mm</p>

Slack adjusters 3

K.. Automatic slack adjusters (ECO-Master (AGS)) 3.2

Slack adjusters, booster brackets, return springs

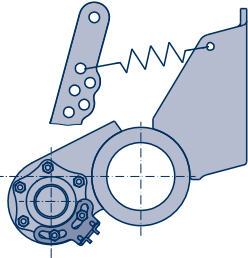
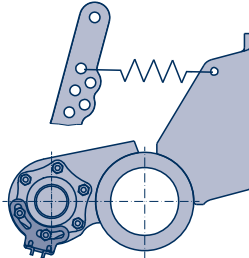
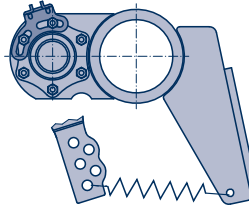
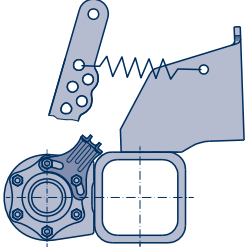
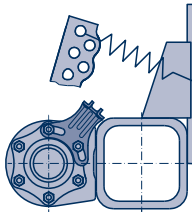
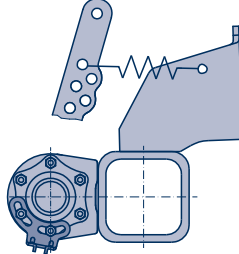
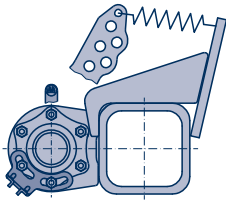
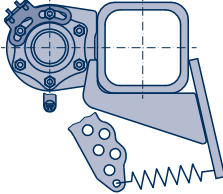
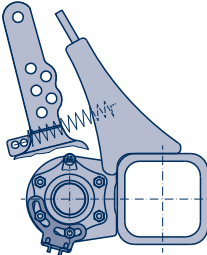
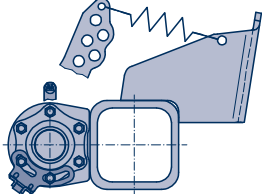
<p>KR..</p>  <p>ECO-Master $\alpha=120^\circ$ 05.174.82.21.3 Return spring 05.397.26.03.0 Booster bracket 03.182.34.95.0 Piston rod 227 mm</p>	<p>KR..</p>  <p>ECO-Master $\alpha=120^\circ$ 05.174.82.21.3 Return spring 05.397.26.03.0 Booster bracket 03.182.34.95.0 Piston rod 227 mm</p>	<p>KR..</p>  <p>ECO-Master $\alpha=210^\circ$ 05.174.82.32.3 Return spring 05.397.26.03.0 Booster bracket 05.182.16.60.0 Piston rod 227 mm</p>
<p>KH..</p>  <p>ECO-Master $\alpha=24^\circ$ 05.174.82.63.3 Return spring 03.397.26.03.0 Booster bracket 03.182.35.80.0 Piston rod 227 mm</p>	<p>KH..</p>  <p>ECO-Master $\alpha=24^\circ$ 05.174.82.67.3 Return spring 05.397.26.03.0 Booster bracket 03.182.33.10.0 Piston rod 180 mm</p>	<p>KH..</p>  <p>ECO-Master $\alpha=180^\circ$ 05.174.82.24.3 Return spring 05.397.26.03.0 Booster bracket 03.182.35.80.0 Piston rod 227 mm</p>
<p>KH..</p>  <p>ECO-Master $\alpha=194^\circ$ 05.174.88.51.3 Return spring 05.397.28.01.0 Booster bracket 05.182.27.03.0 Piston rod 155 mm</p>	<p>KH..</p>  <p>ECO-Master $\alpha=194^\circ$ 05.174.88.51.3 Return spring 03.397.28.01.0 Booster bracket 05.182.27.03.0 Piston rod 155 mm</p>	<p>KH..</p>  <p>ECO-Master $\alpha=210^\circ$ 05.174.83.04.3 Return spring 05.397.26.06.0 Booster bracket 03.182.17.45.0 Piston rod 82 mm</p>
<p>KH..</p>  <p>ECO-Master $\alpha=210^\circ$ 05.174.88.51.3 Return spring 05.397.26.03.0 Booster bracket 03.182.35.83.0 Piston rod 227 mm</p>		

3 Slack adjusters

3.2 Automatic slack adjusters (ECO-Master (AGS))

N..

Slack adjusters, booster brackets, return springs

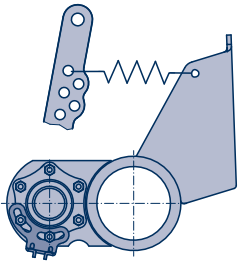
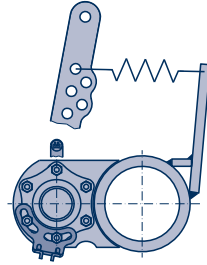
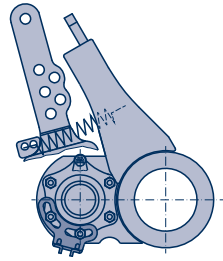
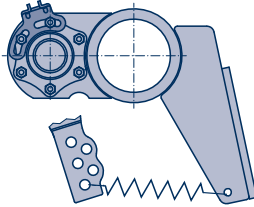
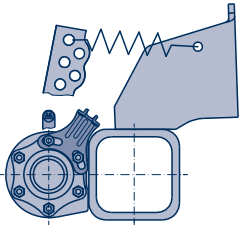
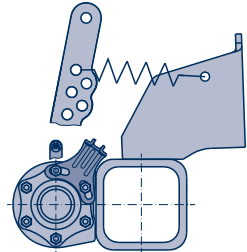
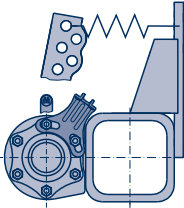
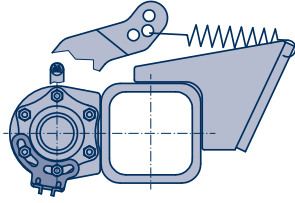
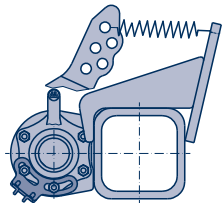
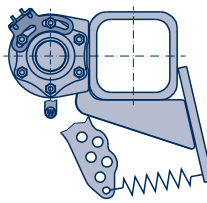
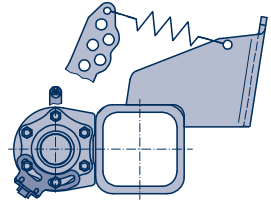
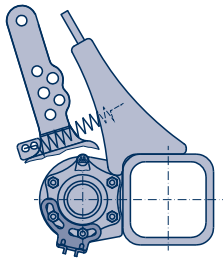
<p>NR..</p>  <p>ECO-Master $\alpha=180^\circ$ 05.174.82.24.3 Return spring 05.397.26.03.0 Booster bracket $25^\circ/30^\circ$ 03.182.34.65.0 Piston rod 227 mm</p>	<p>NR..</p>  <p>ECO-Master $\alpha=180^\circ$ 05.174.82.24.3 $\alpha=180^\circ$ PAL 05.174.82.14.3 Return spring 05.397.26.03.0 Booster bracket 03.182.07.21.0 Piston rod 180 mm</p>	<p>NR..</p>  <p>ECO-Master $\alpha=210^\circ$ 05.174.82.40.3 Return spring 05.397.26.03.0 Booster bracket 05.182.17.14.0 Piston rod 82 mm</p>
<p>NR..</p>  <p>ECO-Master $\alpha=180^\circ$ 05.174.82.14.3 Return spring 05.397.26.03.0 Booster bracket 03.182.16.60.0 Piston rod 227 mm</p>	<p>NH..</p>  <p>ECO-Master $\alpha=24^\circ$ 05.174.82.67.3 Return spring 05.397.26.03.0 Booster bracket 03.182.35.80.0 Piston rod 227 mm</p>	<p>NH..</p>  <p>ECO-Master $\alpha=24^\circ$ 05.174.82.63.3 Return spring 05.397.26.03.0 Booster bracket 05.182.35.80.0 Piston rod 227 mm</p>
<p>NH..</p>  <p>ECO-Master $\alpha=24^\circ$ 05.174.82.67.3 Return spring 05.397.28.01.0 Booster bracket 03.182.33.10.0 Piston rod 180 mm</p>	<p>NH..</p>  <p>ECO-Master $\alpha=180^\circ$ 05.174.89.05.3 Return spring 05.397.26.03.0 Booster bracket 05.182.16.95.0 Piston rod 190 mm</p>	<p>NH..</p>  <p>ECO-Master $\alpha=210^\circ$ 05.174.88.99.3 05.174.88.51.3 Return spring 05.397.28.01.0 Booster bracket 05.182.27.03.0 Piston rod 155 mm</p>
<p>NH..</p>  <p>ECO-Master $\alpha=210^\circ$ 05.174.88.99.3 05.174.88.51.3 Return spring 05.397.28.01.0 Booster bracket 05.182.27.03.0 Piston rod 155 mm</p>	<p>NH..</p>  <p>ECO-Master $\alpha=210^\circ$ 05.174.88.51.3 Return spring 05.397.26.03.0 Booster bracket 03.182.35.83.0 Piston rod 227 mm</p>	<p>NH..</p>  <p>ECO-Master $\alpha=210^\circ$ 05.174.82.64.3 Return spring 03.397.26.06.0 Booster bracket 03.182.17.45.0 Piston rod 82 mm</p>

Slack adjusters 3

Automatic slack adjusters (ECO-Master (AGS)) 3.3

Installation instruction

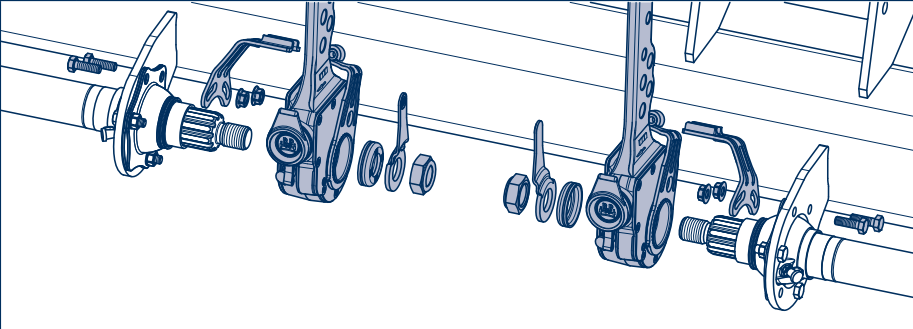
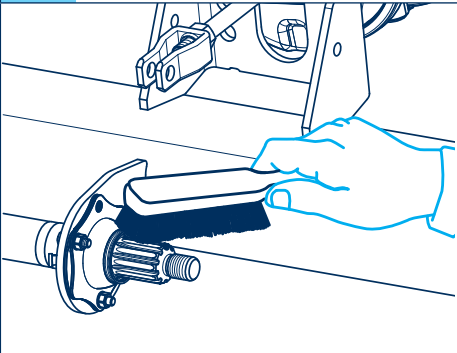
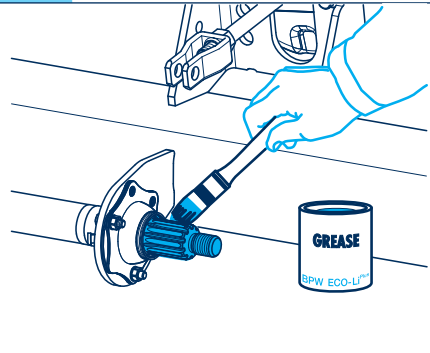
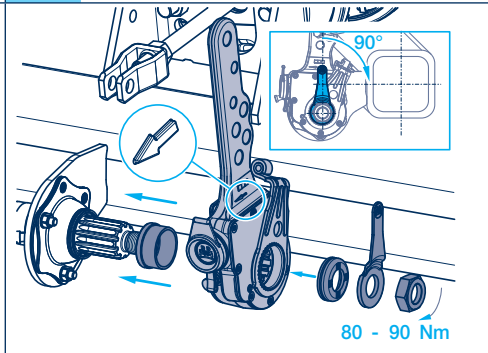
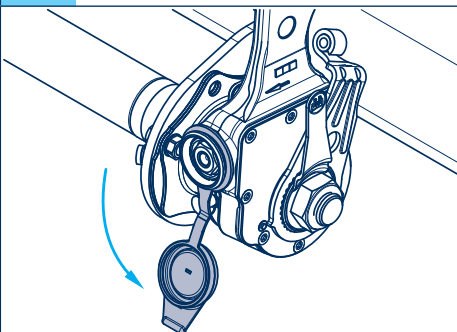
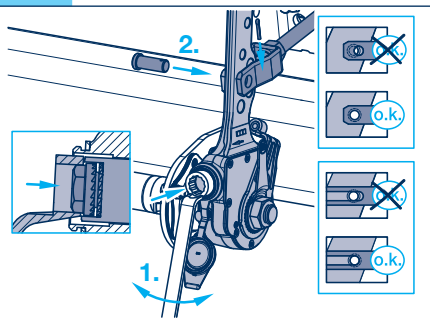
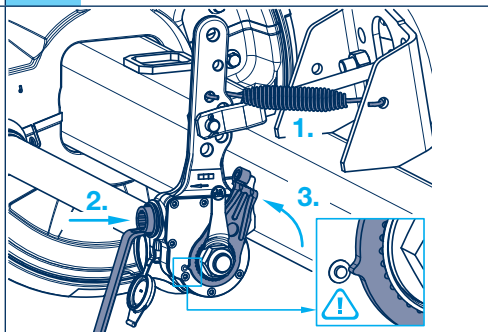
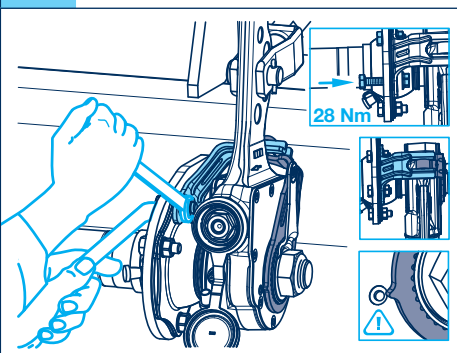
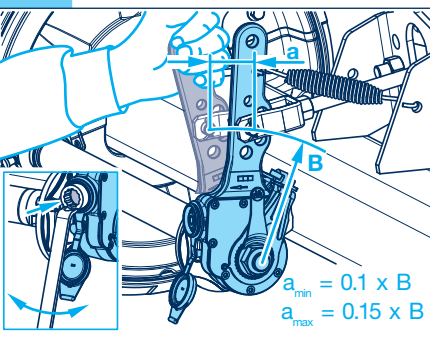
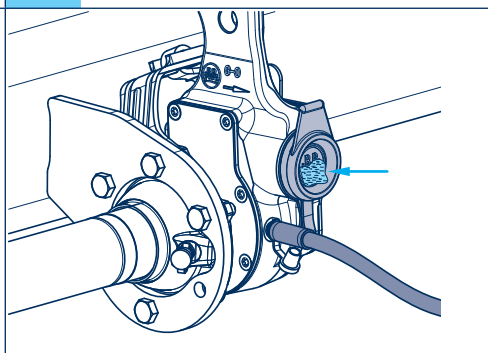
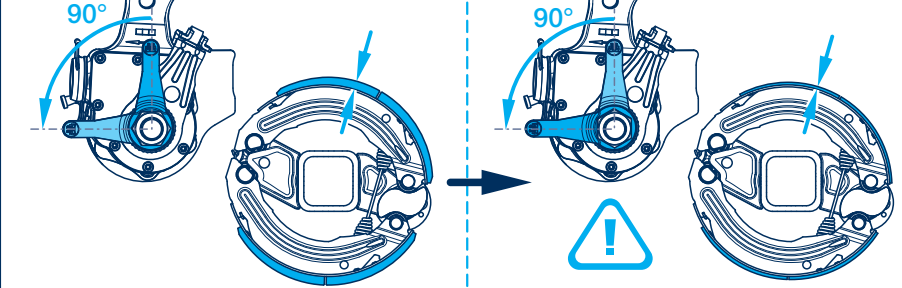
			<p>Simple retro-installation</p> <p>The BPW ECO-Master meets the ECE Regulation No. 13.</p> <p>In conjunction with BPW axles, the tests are carried out by the TÜV.</p>
<p>1 Clean</p> 	<p>2 Grease</p> 	<p>3 Mount</p> 	
<p>4 Open cap</p> 	<p>5 Mount yoke</p> 	<p>6 Adjust</p> 	
<p>7 Secure</p> 	<p>8 Check</p> 	<p>9 Grease</p> 	
			<p>The ECO-Master is of low maintenance.</p> <p>BPW brake cylinders with a round hole yoke eliminates the outer return spring.</p> <p>Lubricate every year and with each brake lining change in on-road use, every 6 months in off-road use and in use outside Europe.</p> <p>Carry out operational check every 6 months, quarterly in use outside Europe. (see Service and Maintenance Instructions)</p>

H
K
N

3 Slack adjusters

3.4 Automatic slack adjusters (ECO-Master)

Slack adjuster attachments

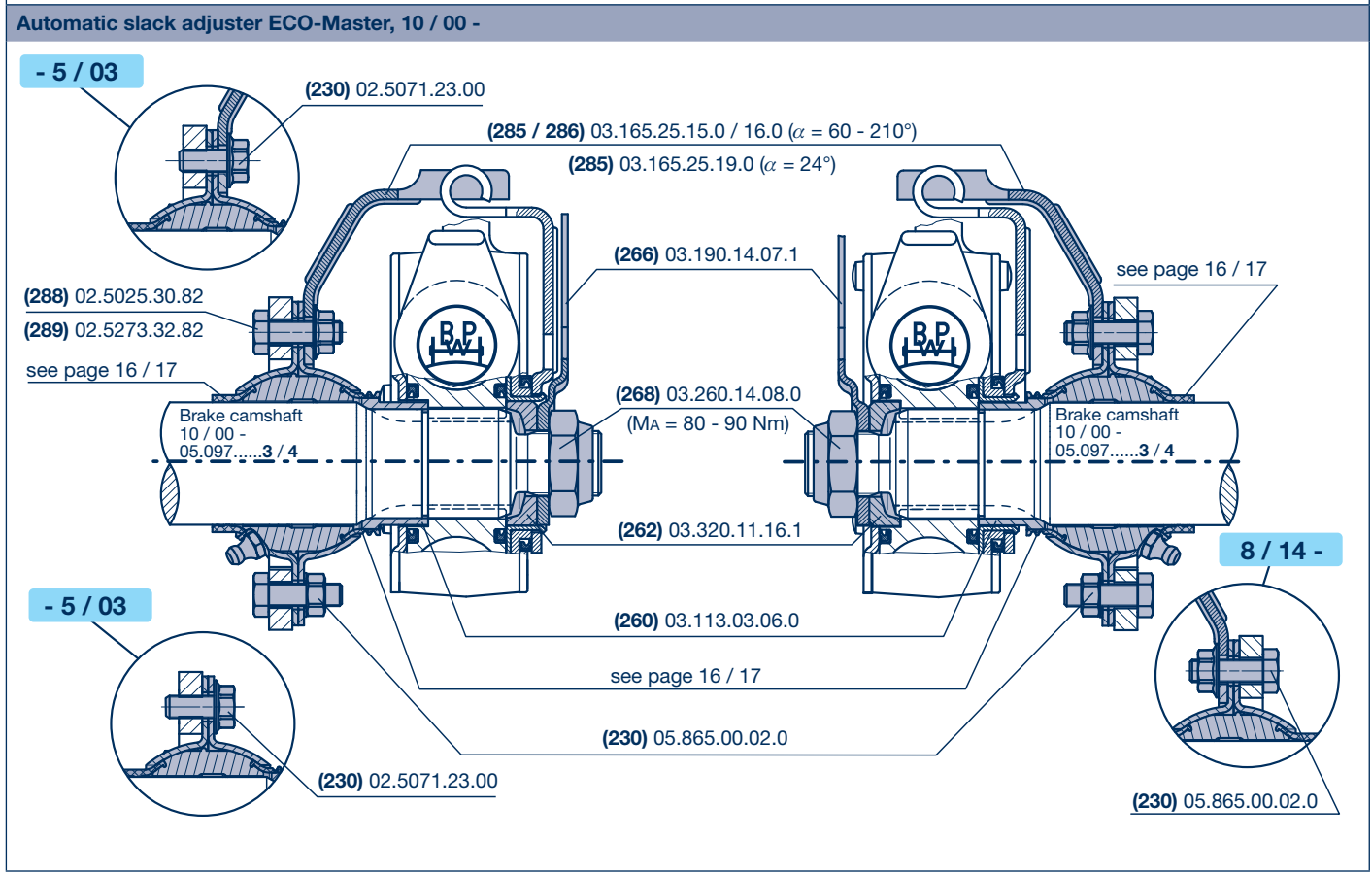
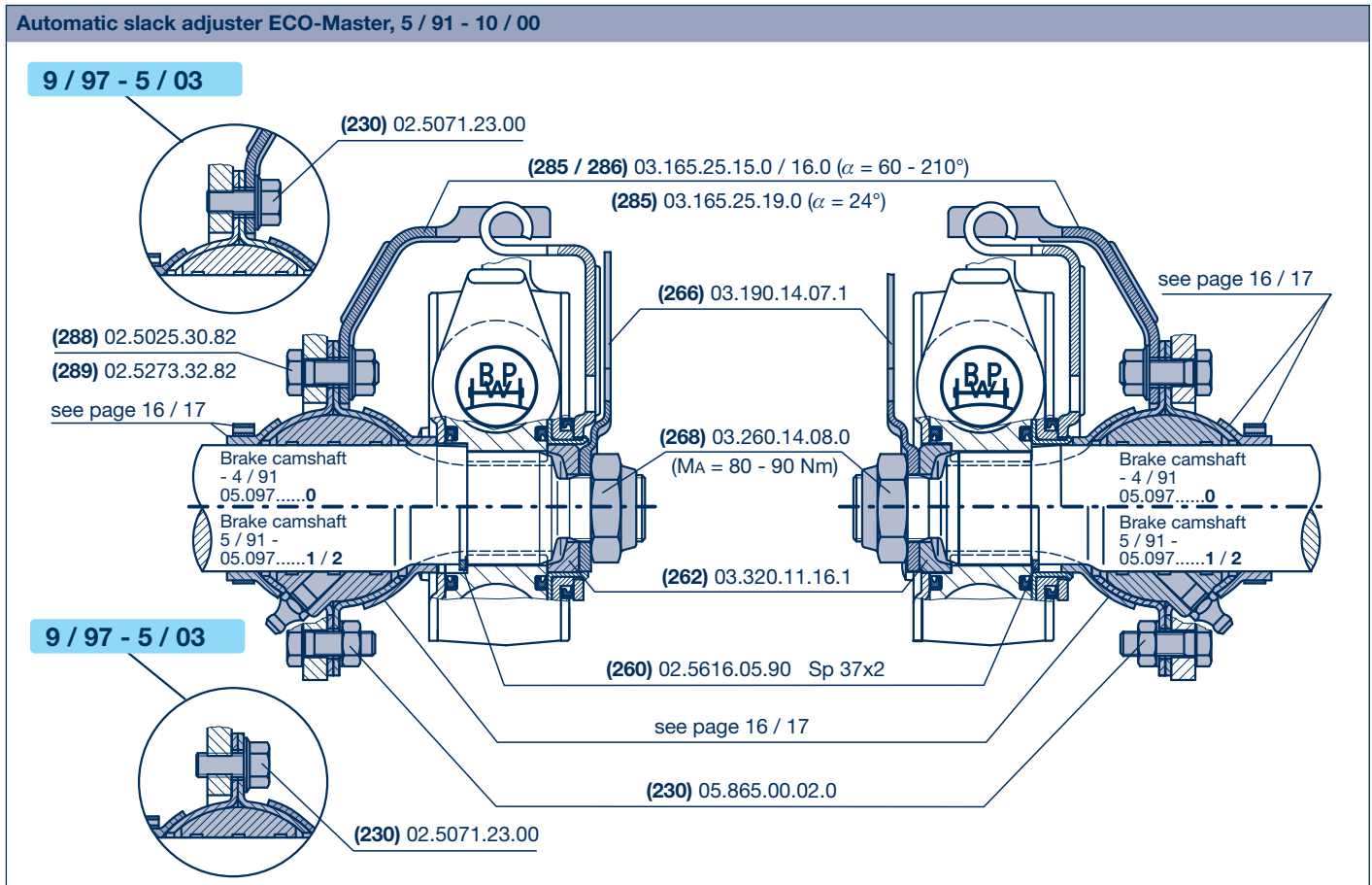

Slack adjusters 3

Automatic slack adjusters (ECO-Master) 3.4

Slack adjuster attachments

Item	Designation	BPW Code no.	Dimension
		for ECO-Master (autom.) 5 / 91 -	
285	Shaped plate	03.165.25.19.0	$\alpha = 24^\circ$
285	Shaped plate	03.165.25.15.0	$\alpha = 60 - 210^\circ$
286	Shaped plate	03.165.25.16.0	$\alpha = 60 - 210^\circ$
		5 / 91 - 8 / 14	
288	Hexagon bolt	02.5025.30.82	M 8 x 25 / 933
289	Lock nut	02.5273.32.82	M 8
		8 / 14 -	
230	Bolt assembly (incl. item 232)	05.865.00.02.0	
232	Lock nut	02.5273.48.82	M 8
		<p>$\alpha = 24^\circ$</p> <p>M = 28 Nm 289 - 8 / 14 232 8 / 14 - 288 - 8 / 14 230 8 / 14 -</p>	
		<p>$\alpha = 60 - 210^\circ$</p> <p>M = 28 Nm 289 - 8 / 14 232 8 / 14 - 288 - 8 / 14 230 8 / 14 -</p>	
		for ECO-Master (autom.) (9 / 97 - 5 / 03)	
285	Shaped plate	03.165.25.....	see above
230	Locking bolt	02.5071.23.00	M 8 x 20
<p>No longer available.. Retrofit to hexagon screw with lock nut, see above., if necessary, make holes in the support bearing plate (Ø 9 mm).</p>			
		<p>285 230 M = 28 Nm</p>	

H
K
N

4 Brake parts

General

BPW Drum brakes

The proven technology and robust construction of BPW drum brakes makes them suitable for every application. They shrug off dirt and are extremely hard wearing, even under the harshest conditions.

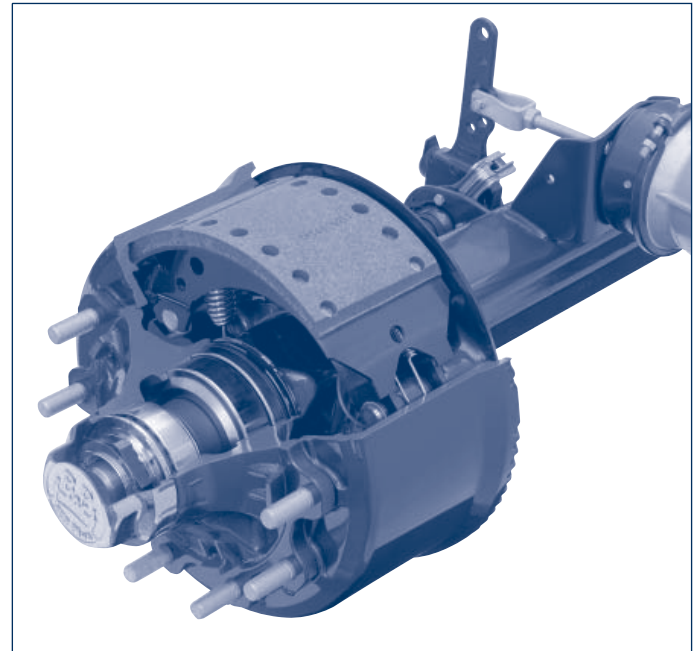

Function

The force from the brake cylinders is transmitted by the slack adjuster to the brake camshaft causing it to rotate. The S-cam forces the brake shoes apart, pressing them against the inside of the brake drum.

When the brake is released, the brake camshaft rotates the S-cam back to its neutral position.

The brake shoes are returned to their initial position by return springs.

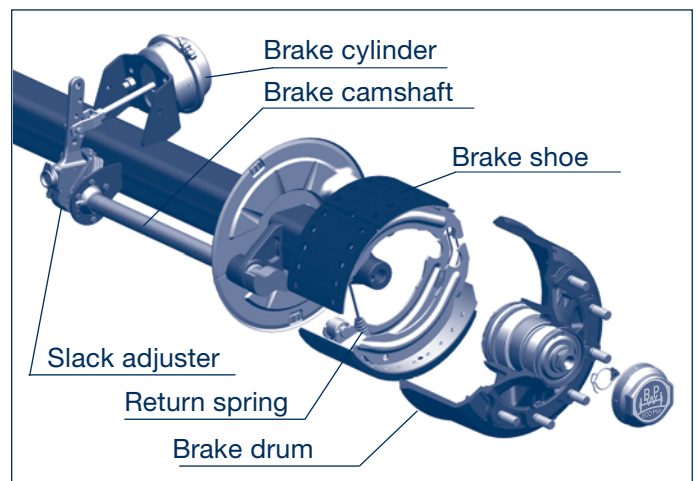

Brake parts 4

General

Conversion to brake with split roller (BPW 95 brake)

Brakes of the former version should be changed over to new brake technology.

High degree of safety

Short response time and a consistent braking effect throughout the entire life of the lining thanks to the permanently lubricated brake rollers.

Reduced own weight

Weight-optimized design with fewer wear parts.

Easy to change brake linings

Fast and easy brake shoe replacement.

Same brake components on all axles of the corresponding series

The technical specifications of the brake remain unchanged. Consequently existing EC test certificates remain valid.

Retention spring

The retention springs ensure the brake shoes are firmly and securely seated on the C-clamps (Fig. SN 42..).

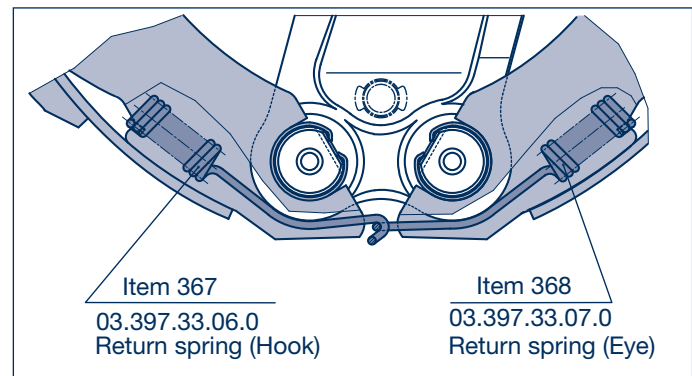
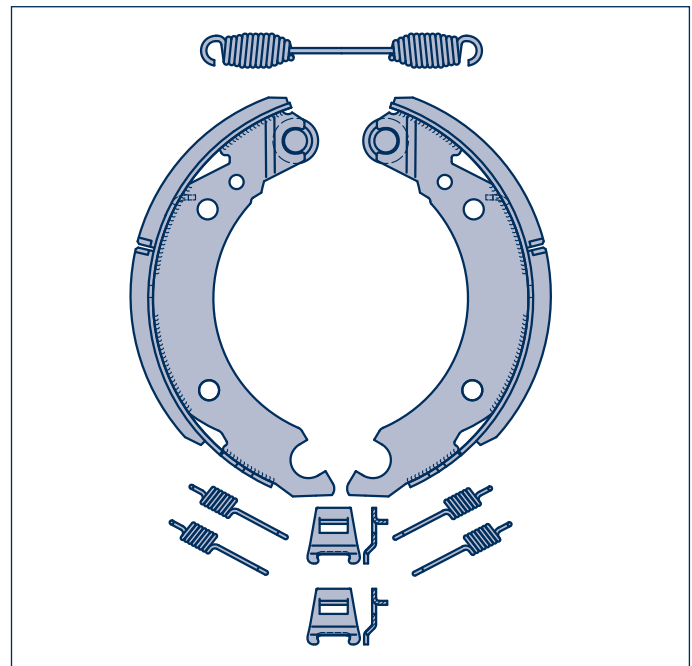

Brake return springs

The brake return spring is hooked into lugs that are formed on the brake shoes.

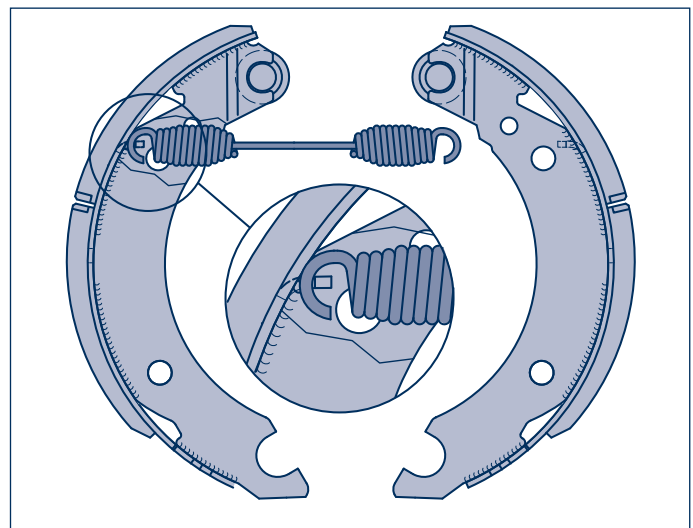

H

K

N

4 Brake parts

General

BPW ECO Drum

BPW Bergische Achsen KG has been a leader in the field of drum brake technology for many years, and has significantly extended its position as the market leader. The customers of over 11 million drum brakes from BPW value the proven technology, the sturdy construction and the simple maintenance of the BPW drum brake.

In a further development stage the tried and tested SN 4218 and SN 4220 brakes have now been improved yet again in terms of weight, wear behaviour and service-friendliness.

The result of this development is called the **ECO Drum**.

BPW axles with ECO Drum brakes include BPW's proven drum brake technology along with a reduction in weight. As a result of improved component design, the weight of the 9-tonne drum brake axle with ECO Drum SN 4218 in conjunction with the revised air suspension has been reduced by approx. 18 kg per axle (see also BPW NEWS Gen. 7125703e). For you that means reduced weight and increased payload.

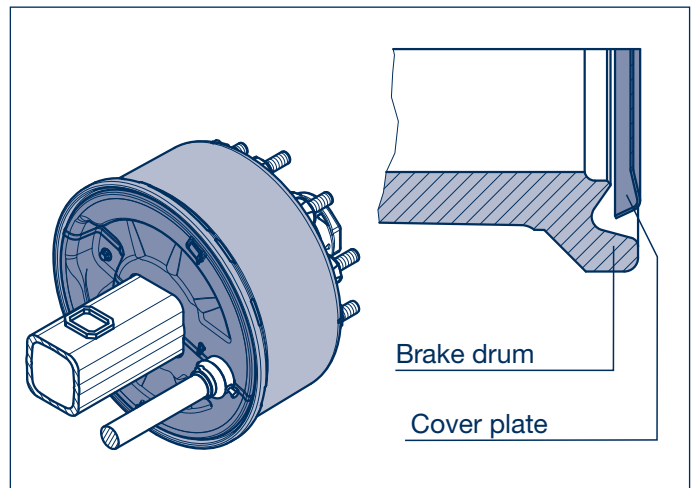
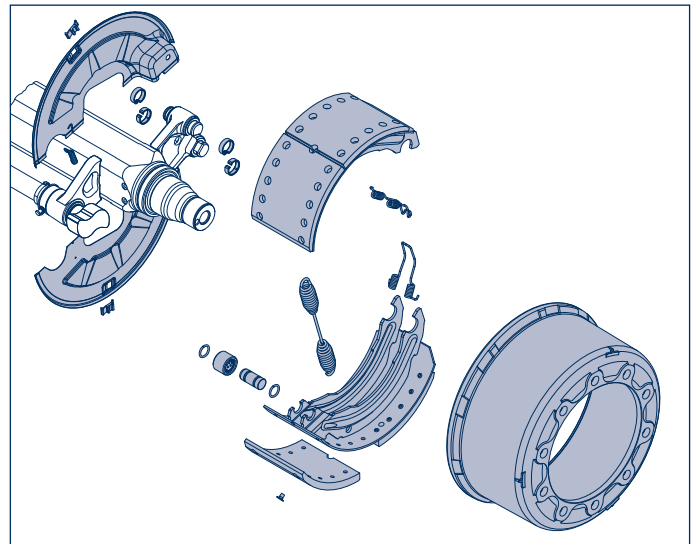
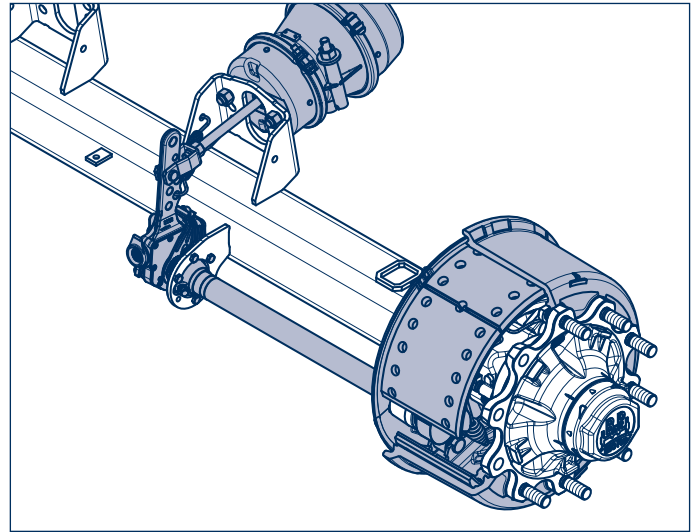

Brake parts 4

General

BPW ECO Drum

The quality of the cover plate attachment has been improved by the use of bolts. They ensure that the cover plate can be removed with no difficulty at all, even after years of use under the harshest conditions.

On the camshaft side the cover plate is simply and quickly plugged in and held by a spring.

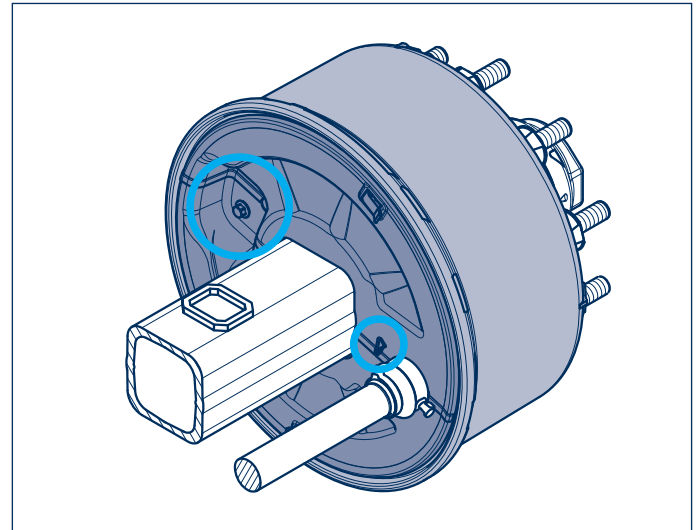

Spares compatibility

In future there will only be the new ECO Drum brake drums and brake shoes available.

The new brake drums and brake shoes can also be used on the old drum brake axles without replacing the cover plate.

There is also the opportunity to get cover plates with the new external contour and the old brake anchor plate connection.

In this way customers can benefit from the improved seal between the new cover plate and the brake drum design even with old drum brake axles.

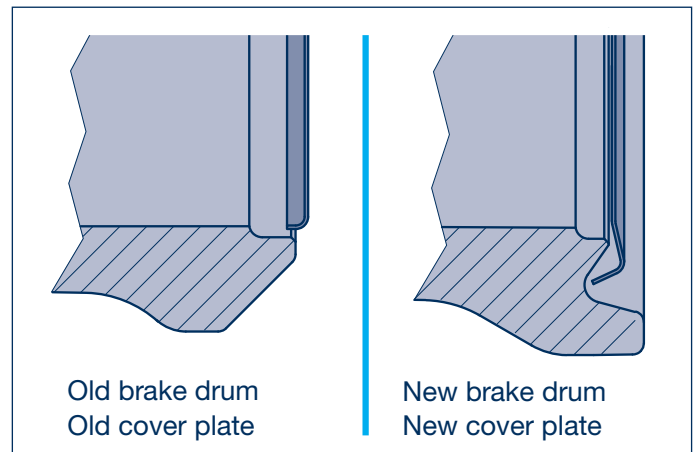

Brake certificates

No new homologations are required for the ECO Drum. The updated brake certificates for the ECO Drum SN 42.. can be found under the familiar TDB numbers in the download centre on the BPW homepage at www.bpw.de.

The BPW axle with ECO Drum brakes can be fitted to a vehicle together with the previous drum brake axle.

H

K

N

4 Brake parts

4.1 Conventional brake (Year of manufacture 1983 - 1995) SN 4212-2 / 4218-2 / 4220-2 / 4222-2

H.. / R..

H

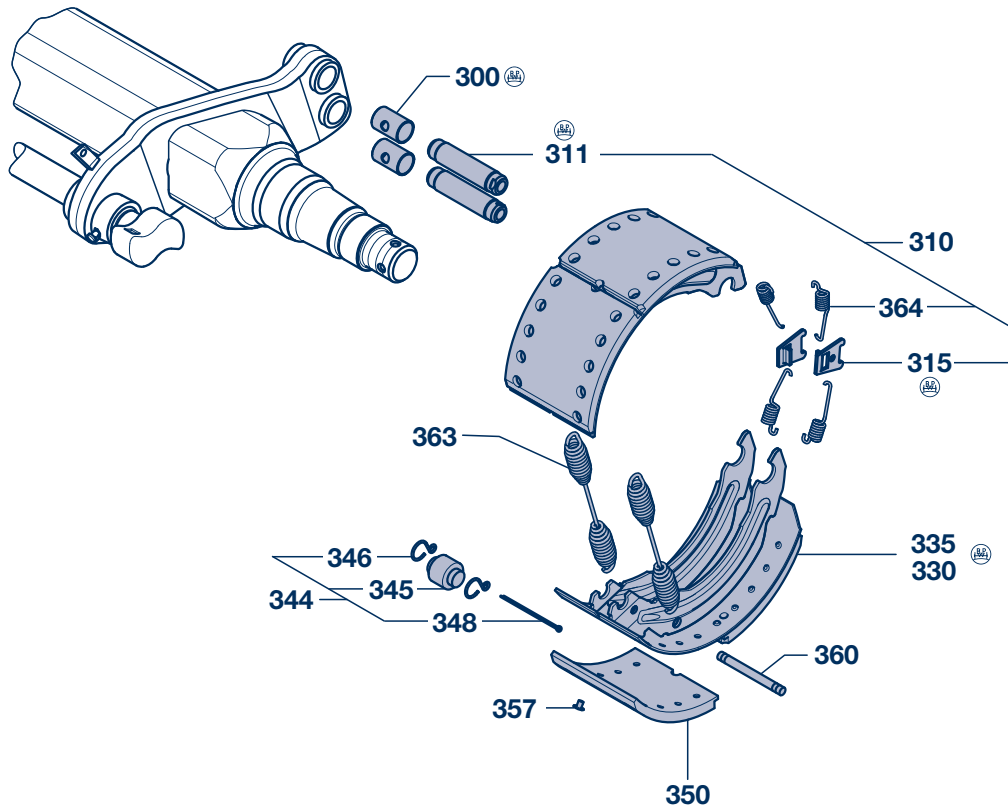

Conversion to brake with split roller (BPW 95 / ECO Drum)

H.. / R..

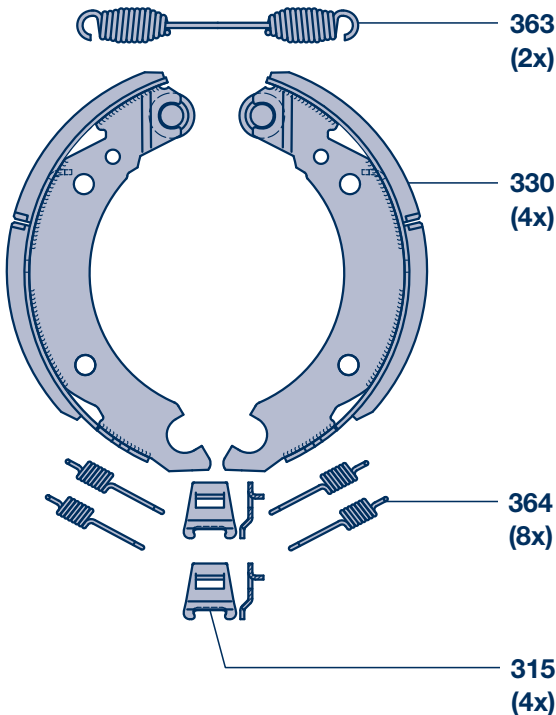

Conversion to brake with split roller (BPW 95 / ECO Drum)

High degree of safety

Short response time and a consistent braking effect throughout the entire life of the lining thanks to the permanently lubricated brake rollers.

Reduced own weight

Weight-optimized design with fewer wear parts.

Easy to change brake linings

Fast and easy brake shoe replacement.

Same brake components on all axles of the corresponding series

The technical specifications of the brake remain unchanged. Consequently existing EC test certificates remain valid.

Brake parts 4

H.. / R..

Conventional brake (Year of manufacture 1983 - 1995)

4.1

SN 4212-2 / 4218-2 / 4220-2 / 4222-2

Item	Designation	Dimension	BPW Code no.			
			SN 4212-2	SN 4218-2	SN 4220-2	SN 4222-2
			SN 4212-2 SN 4218-2 SN 4220-2	---,790. / 794.--- ---,710. / 714.--- ---,718. / 723.---	SN 4222-2	---,739.---
300	Bush	Ø 36 / 40 x 60	03.112.33.08.0		03.112.33.08.0	
310	Brake bolt cpl. (item 311, 315)		09.084.46.36.0		09.084.46.35.0	
311	Brake bolt	Ø 36 x 135	03.084.46.22.0		-	
		Ø 36 x 145	-		03.084.46.23.0	
315	Shaped plate		03.167.23.02.0		03.167.23.02.0	
			SN 4212-2	SN 4218-2	SN 4220-2	SN 4222-2
330	Brake shoe assembly, with lining (incl. item 345 - 357)		No longer available. Retrofit to brake with split roller (BPW 95 / ECO Drum). (see below)			
335	Brake shoe assembly, without lining (incl. item 345 - 348)					
344	Repair kit brake shoe roller (item 345 - 348)		-		09.801.02.10.0	(for 1 axle)
345	Roller	Ø 26 / 42 x 52	03.331.34.06.0		-	
		Ø 26 / 42 x 78	-		03.331.34.05.0	
346	Circlip		03.350.00.13.0		03.350.00.13.0	
348	Split pin	6.3 x 71 / 1234	02.6201.64.01		-	
		6.3 x 90 / 1234	-		02.6201.66.03	
349	Repair kit brake lining (item 350 (8x))	18 mm	-	09.801.07.41.0	09.801.07.45.0	
		19 mm	-	09.801.07.42.0	09.801.07.46.0	
		20 mm	-	09.801.07.43.0	09.801.07.47.0	
350	Brake lining (Textar T090)	18 mm	03.092.29.53.0	03.092. *	03.092. *	03.092.28.32.0
		19 mm	03.092.29.54.0	03.092. *	03.092. *	-
		19.5 mm	03.092.29.55.0	-	-	-
		20 mm	-	03.092. *	03.092. *	-
357	Rivet (Steel)	B 8 x 15/7338	02.5805.80.35		02.5805.80.35	
360	Splined pin	Ø 12 x 70	03.001.08.04.0		-	
		Ø 12 x 90	-		03.001.08.05.0	
363	Return spring	Ø 25 / 5 x 269	05.397.56.07.0 (1x)		-	
		Ø 25 / 4 x 262	-		05.397.46.07.0	
364	Return spring	Ø 21 / 4 x 105	03.397.44.06.0		03.397.44.06.0	

* not available loose - see repair kit brake lining (item 349)

Conversion to brake with split roller (BPW 95 / ECO Drum)						H.. / R..
Item	Designation	Dimension	BPW Code no.			
			SN 4212-2	SN 4218-2	SN 4220-2	SN 4222-2
315	Shaped plate			03.167.23.09.0		
330	Brake shoe assembly, with lining (incl. item 345 - 357)		05.091.29.92.1	05.091.46.32.1	05.091.47.04.1	05.091.28.28.1
345	Roller	Ø 26 / 45 x 33.5		05.331.44.02.0		
346	Bolt	Ø 26 x 58.5		03.084.75.24.0		
348	Ring	Ø 31 / 24 / 3.5		03.310.70.15.0		
350	Brake lining (Textar T090)	18 mm	03.092.29.53.0	see above	see above	03.092.28.32.0
357	Rivet (Steel)	B 8 x 15/7338		02.5805.80.35		
363	Return spring	Ø 34 / 5 x 274		05.397.58.03.0		
364	Return spring	Ø 21 / 4 x 105		03.397.44.06.0		

4 Brake parts

4.1 Conventional brake (Year of manufacture 1983 - 1995)

K..

SN 3616 / 3620

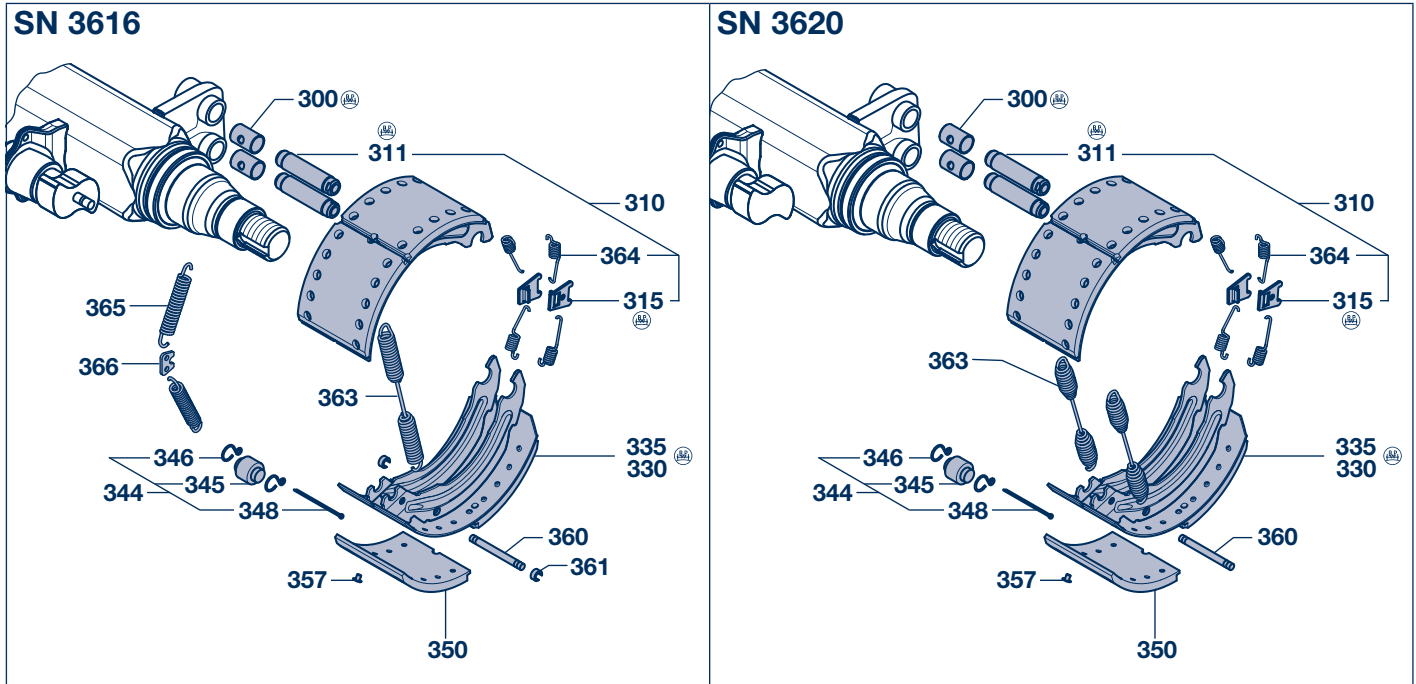

Conversion to brake with split roller (BPW 95 / ECO Drum) K..

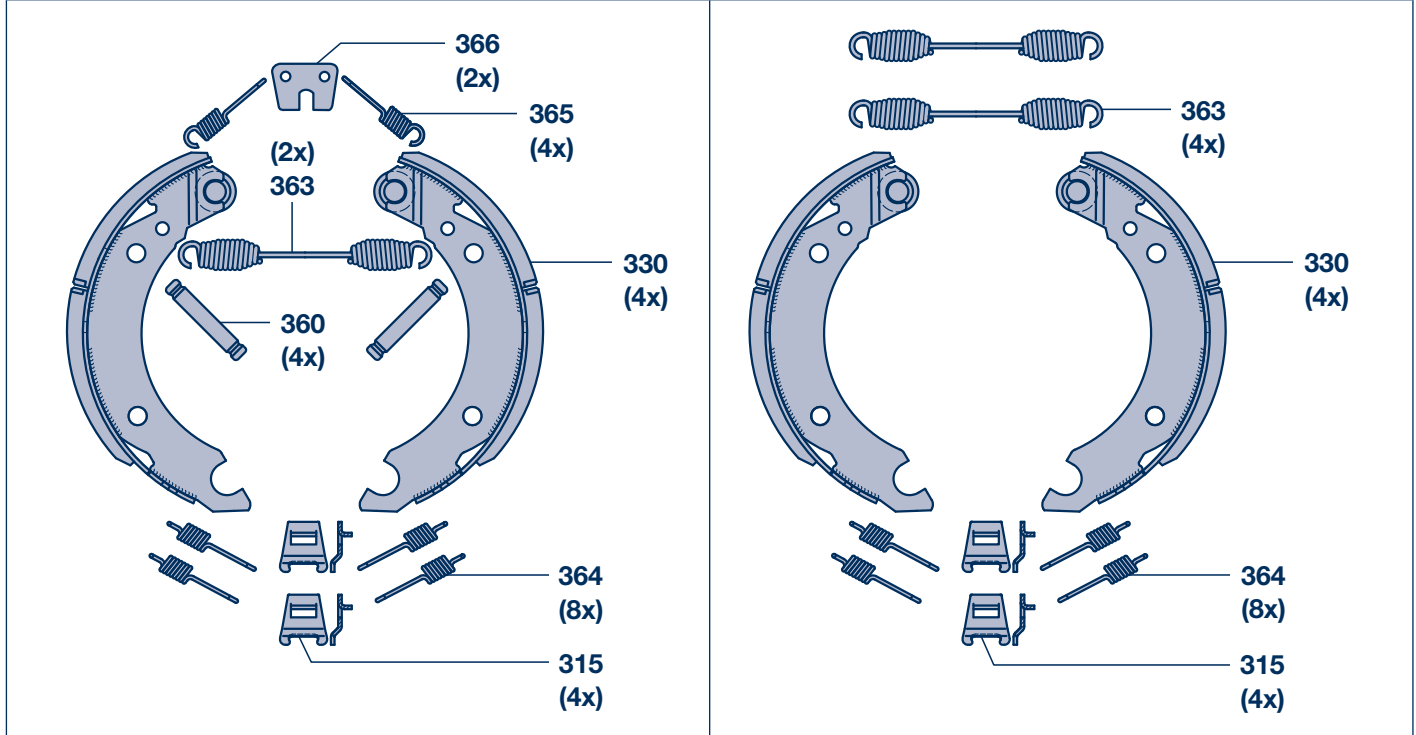

Brake parts 4

K.. Conventional brake (Year of manufacture 1983 - 1995) 4.1 SN 3616 / 3620

Item	Designation	Dimension	BPW Code no.			
			SN 3616 ---.---542.---		SN 3620 ---.---546.---	
300	Bush	Ø 36 / 40 x 60	03.112.33.08.0			
310	Brake bolt cpl. (item 311, 315)		09.084.46.36.0			
311	Brake bolt	Ø 36 x 135	03.084.46.22.0			
315	Shaped plate		03.167.23.02.0			
			SN 3616 ---.---542.---		SN 3620 ---.---546.---	
330	Brake shoe assembly, with lining (incl. item 345 - 357)		No longer available. Retrofit to brake with split roller (BPW 95). (see below)			
335	Brake shoe assembly, without lining (incl. item 345 - 348)					
344	Repair kit brake shoe roller (item 345 - 348)		09.801.02.10.0 (for 1 axle)			
345	Roller	Ø 26 / 42 x 78	03.331.34.05.0			
346	Circlip		03.350.00.13.0			
348	Split pin	6.3 x 90 / 1234	02.6201.66.03			
			Brake pin side 10 Rivets item 350	Camshaft side 8 Rivets item 351	Brake pin side 10 Rivets item 350	Camshaft side 8 Rivets item 351
350 / 351	Brake lining (Textar T090)	18 mm	03.092.19.63.0	03.092.19.62.0	03.092.19.54.0	03.092.19.55.0
		19 mm	03.092.19.64.0	03.092.19.65.0	03.092.19.56.0	03.092.19.57.0
		19.5 mm	03.092.19.66.0	03.092.19.67.0	03.092.19.58.0	03.092.19.59.0
357	Rivet (Steel)	B 8 x 15/7338	02.5805.80.35			
360	Bolt	Ø 12 x 120	03.084.42.03.0		03.084.42.02.0	
361	Circlip	12 SxN 09	02.3301.17.00		-	
363	Return spring	Ø 24 / 4 x 218	05.397.45.14.0			
364	Return spring	Ø 21 / 4 x 105	03.397.44.06.0			
365	Return spring	Ø 22 / 4 x 108	03.397.45.10.0		-	
366	Plate		03.285.22.05.0		-	

* not available loose - see repair kit brake lining (item 349)

Conversion to brake with split roller (BPW 95 / ECO Drum) K..						
Item	Designation	Dimension	BPW Code no.			
			SN 3616		SN 3620	
328	Retrofit kit cpl. for 1 axle, with brake shoes (item 329 + 330)		09.801.02.41.0 (for 1 axle)		09.801.02.40.0 (for 1 axle)	
329	Retrofit kit cpl. for 1 axle, without brake shoes (item 315, 360 - 366)		09.801.02.46.0 (for 1 axle)		09.801.02.45.0 (for 1 axle)	
315	Shaped plate		03.167.23.09.0			
330	Brake shoe assembly, with lining (incl. item 345 - 357)		05.091.19.24.1		05.091.19.22.1	
345	Roller	Ø 26 / 45 x 33.5	05.331.44.02.0			
346	Bolt	Ø 26 x 58.5	03.084.75.24.0			
348	Ring	Ø 31 / 24 / 3.5	03.310.70.15.0			
			Brake pin side 10 Rivets Item 350	Camshaft side 8 Rivets Item 351	Brake pin side 10 Rivets Item 350	Camshaft side 8 Rivets Item 351
350	Brake lining (Textar T090)	18 mm	03.092.29.53.0	03.092.19.62.0	03.092.19.54.0	03.092.19.55.0
357	Rivet (Steel)	B 8 x 15/7338	02.5805.80.35			
360	Bolt	Ø 12 x 125	03.084.42.05.0		-	
363	Return spring	Ø 24.5 / 4 x 236	05.397.46.13.0			
364	Return spring	Ø 21 / 4 x 105	03.397.44.06.0			
365	Return spring	Ø 22 / 4 x 108	03.397.45.10.0		-	
366	Plate		03.285.22.05.0		-	

4 Brake parts

4.1 Conventional brake (Year of manufacture 1983 - 1995)

N..

SN 3015 / 3020

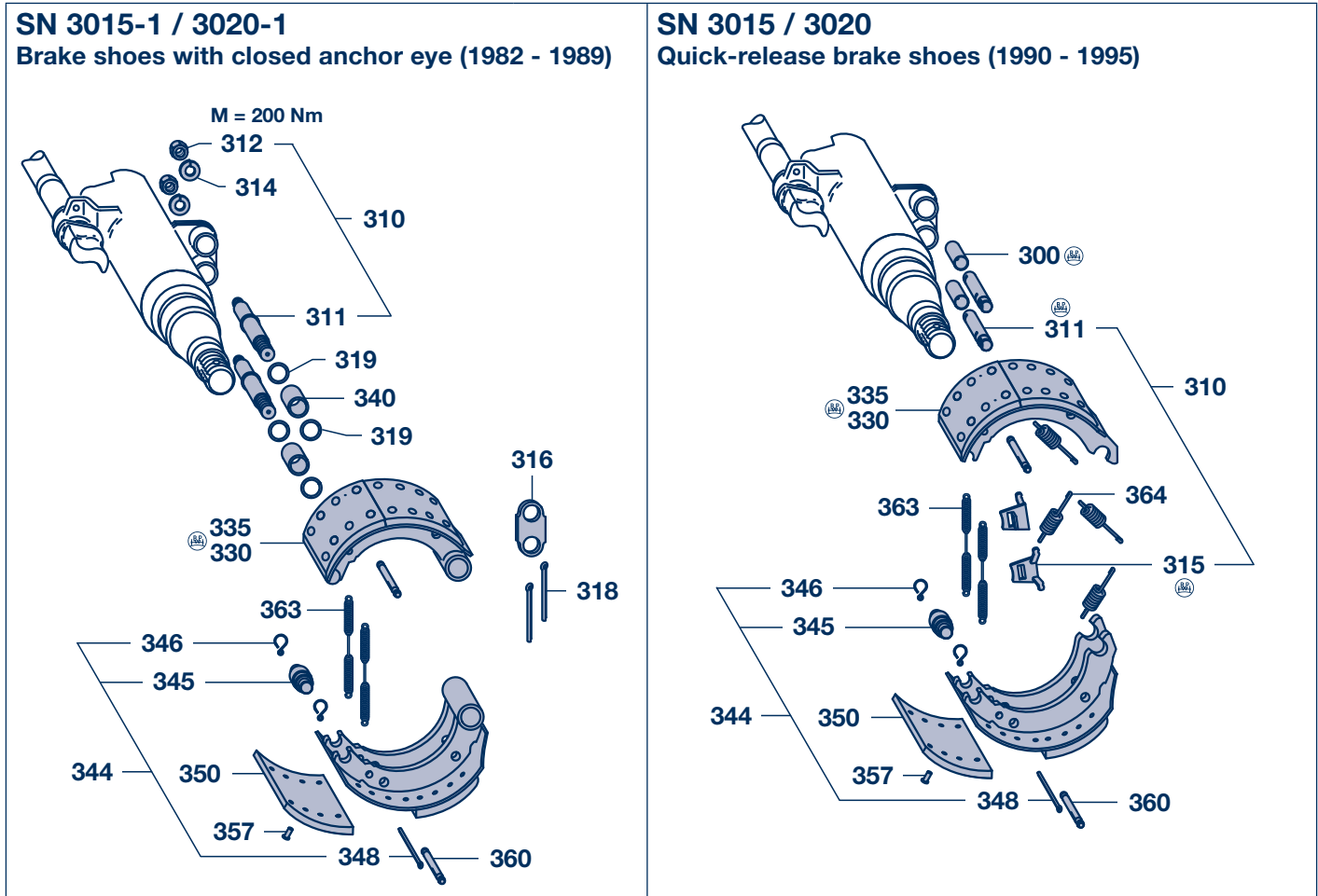

Conversion to brake with split roller (BPW 95 / ECO Drum) N..

Item	Designation	Dimension	BPW Code no.	
			SN 3015	SN 3020
			09.801.02.43.0	09.801.02.42.0
328	Retrofit kit cpl. for 1 axle, with brake shoes (item 329 + 330)			
329	Retrofit kit cpl. for 1 axle, without brake shoes (item 315, 363, 364)		09.801.02.47.0	
315	Shaped plate		03.167.24.01.0	
330	Brake shoe assembly, with lining (incl. item 345 - 357)		05.091.15.05.1	05.091.14.77.1
345	Roller	Ø 26 / 45 x 33.5	05.331.44.02.0	
346	Bolt	Ø 26 x 58.5	03.084.75.24.0	
348	Ring	Ø 31 / 24 / 3.5	03.310.70.15.0	
350	Brake lining (Textar T090)	18 mm	03.092.13.44.0	03.092.14.45.0
357	Rivet (Steel)	B 8 x 15 / 7338	02.5805.80.35	
363	Return spring	Ø 20 / 3.5 x 180	05.397.34.17.0	
364	Return spring	Ø 21 / 4 x 105	03.397.44.06.0	

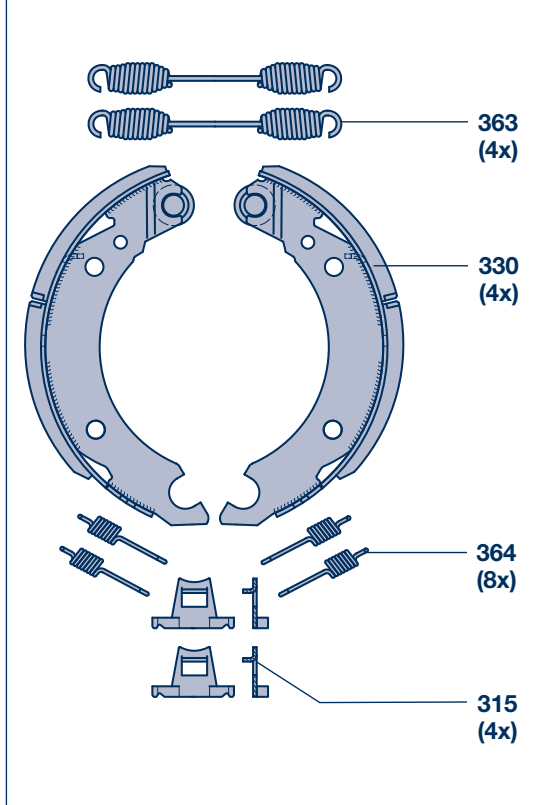

Brake parts 4

N.. Conventional brake (Year of manufacture 1983 - 1995) 4.1 SN 3015 / 3020

Item	Designation	BPW Code no. Dimension			
		SN 3015-1 * ---.582.---	SN 3020-1 * ---.586.---	SN 3015-1 * ---.592.---	SN 3020-1 * ---.596.---
		Brake shoes with closed anchor eye 1982 - 1989		Quick-release brake shoes 1990 - 1995	
300	Bush	-	-	03.112.33.08.0	Ø 36 / 40 x 60
310	Threaded bolt cpl. (item 311, 314, 315)	09.177.23.09.0	-	-	-
310	Brake bolt cpl. (item 311, 315)	-	-	09.084.46.39.0	-
311	Brake bolt	-	-	03.084.46.30.0	Ø 36 x 145 (135)
311	Threaded bolt	03.177.23.10.1	Ø 32 / 38 x 153	-	-
312	Hexagon nut	02.5201.76.06	BM 20 x 1.5 / 439	-	-
314	Spring washer	03.143.00.02.0	Ø 22.5 / 34 / 80°	-	-
315	Shaped plate	-	-	03.167.24.01.0	-
316	Shackle (normal) (for ABS, brake drum width until 260 mm)	03.232.44.02.0 03.232.44.04.0	-	-	-
318	Split pin	02.6201.80.01	8 x 45 / 1234	-	-
319	'O'-Ring	02.5677.86.40	Ø 28 x 2.5	-	-
		SN 3015-1 *	SN 3020-1 *	SN 3015	SN 3020
		NR.. Ø 127 ---.582.---	NR.. Ø 127 ---.586.---	NR.. Ø 127 ---.592.---	NH.. □ 120 ---.592.---
				NH.. □ 120 ---.596.---	NH.. □ 120 ---.596.---
330	Brake shoe assembly, with lining (incl. item 340, 345 - 357)	05.091.13.85.0	05.091.14.70.0	No longer available. Retrofit to brake with split roller (BPW 95). (see page 45, item 328)	
335	Brake shoe assembly, without lining (incl. item 340, 345 - 348)	05.091.13.20.0	05.091.14.19.0		
340	Bush	03.112.22.30.0	Ø 32 / 36x54	-	-
344	Repair kit brake shoe roller (item 345 - 348)	09.801.02.11.0	(for 1 axle)	09.801.02.12.0	(for 1 axle)
345	Roller	03.331.34.01.0	Ø 22 / 42x59	03.331.34.01.0	Ø 22 / 42x59
346	Shackle	03.232.13.01.0	-	-	-
346	Circlip	-	-	03.350.00.14.0	-
348	Split pin	02.6201.83.03	Ø 8 x 71/1234	02.6201.66.03	Ø 6.3 x 90 / 1234
350 / 351	Brake lining 18 mm (Textar T090) 19 mm 19.5 mm	03.092.13.44.0 03.092.13.45.0 03.092.13.46.0	03.092.14.45.0 03.092.14.46.0 03.092.14.47.0	03.092.13.44.0 03.092.13.45.0 03.092.13.46.0	03.092.14.45.0 03.092.14.46.0 03.092.14.47.0
357	Rivet (Steel)	02.5805.80.35	B 8 x 15/7338	-	-
360	Splined pin	03.001.08.03.0	Ø 12 x 70	03.001.08.05.0	Ø 12 x 90
363	Return spring	05.397.35.03.0	Ø 22/3.6x163	-	-
	Ø 24/4x167	-	-	05.397.46.12.0	-
	Ø 20/3.6x166	-	-	-	05.397.46.12.0
		-	-	05.397.34.16.0	-
364	Return spring	-	-	03.397.44.06.0	Ø 21 / 4 x 105

* Brake shoes with closed location eyes (Execution-1)
can not be fitted to brake with split roller (BPW 95).

4 Brake parts

4.2 Brake with split roller (BPW 95) (Manufactured from 3/95)

H.. / R..

SN 4212 / 4218 / 4220 / 4222 BPW 95 / ECO-Drum

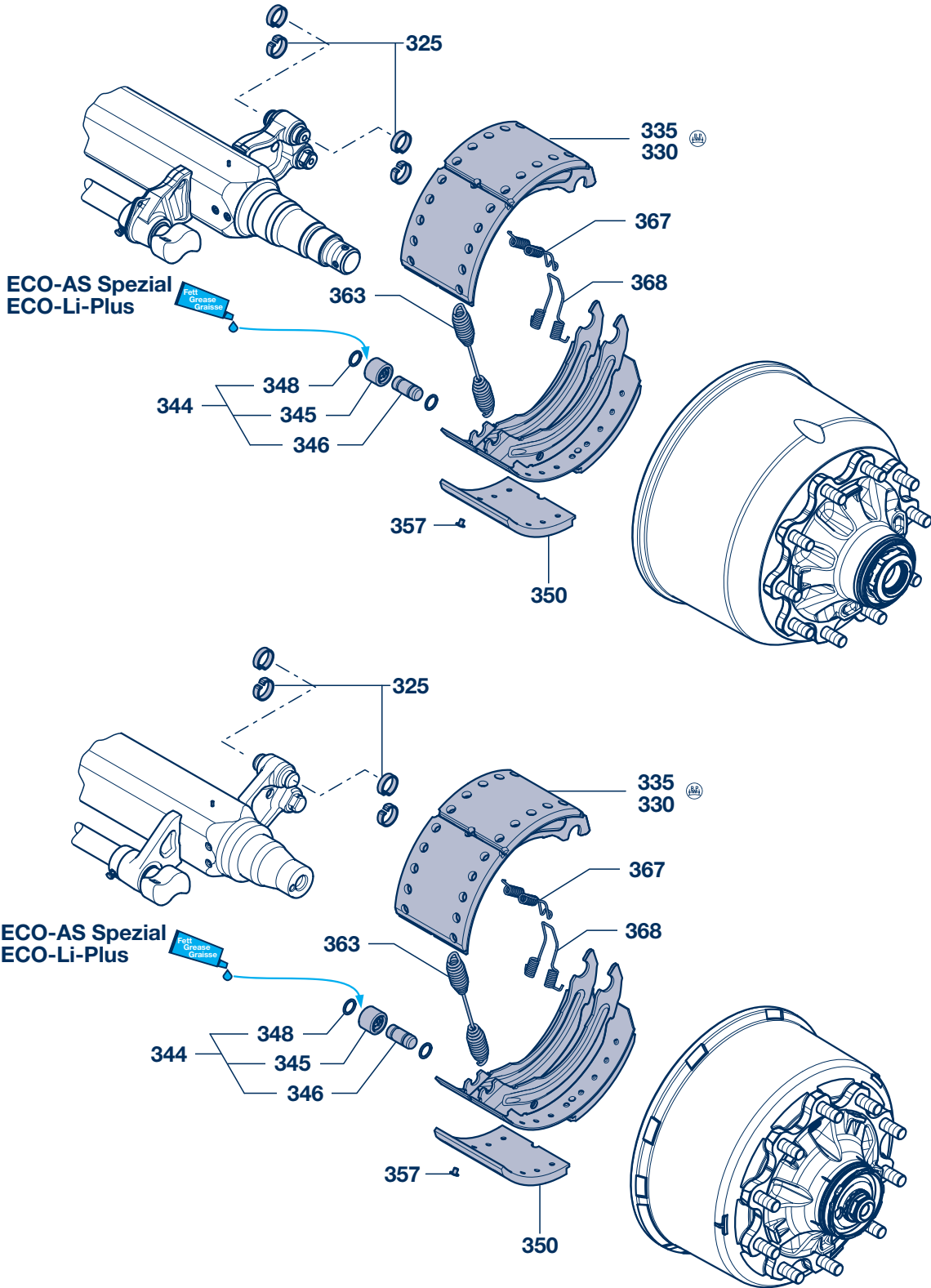

Brake parts 4

H.. / R.. Brake with split roller (BPW 95) (Manufactured from 3/95) 4.2

SN 4212 / 4218 / 4220 / 4222 BPW 95 / ECO-Drum

Item	Designation	Dimension	BPW Code no.			
			SN 4212 ---.741.---	SN 4218 ---.743.---	SN 4220 ---.744.---	SN 4222 ---.745.---
325	'C' Clip		03.188.02.02.0			
327	Repair kit brake, without brake shoes (item 325, 363 - 368)	(for 1 axle)	09.801.06.79.0			
328	Repair kit brake, with brake shoes (item 327, 330)	(for 1 axle)	-	09.801.07.39.0	09.801.07.49.0	09.801.02.53.0
330	Brake shoe assembly, with lining, (incl. item 345 - 357)		05.091.29.92.1	05.091.46.32.1	05.091.47.04.1	05.091.28.28.1
335	Brake shoe assembly, without lining, (incl. item 345 - 348)		05.091.29.93.0	05.091.46.36.0	05.091.47.09.0	05.091.28.29.0
344	Repair kit brake shoe roller (item 345 - 348)		09.801.02.91.0 (for 1 axle side)			
345	Roller	Ø 26 / 45 x 33.5	05.331.44.02.0			
346	Bolt	Ø 26 x 58.5	03.084.75.24.0			
348	Ring	Ø 24 / 31 / 3.5	03.310.70.15.0			
349	Repair kit brake lining (for 1 axle, item 350 (8x))	18 mm	-	09.801.07.41.0	09.801.07.45.0	
		19 mm	-	09.801.07.42.0	09.801.07.46.0	
		20 mm	-	09.801.07.43.0	09.801.07.47.0	
350	Brake lining (Textar T090)	18 mm	03.092.29.53.0	03.092. *	03.092. *	03.092.28.32.0
		19 mm	03.092.29.54.0	03.092. *	03.092. *	-
		19.5 mm	03.092.29.55.0	-	-	-
		20 mm	-	03.092. *	03.092. *	-
357	Rivet (Steel)	B 8 x 15 / 7338	02.5805.80.35			
363	Return spring	Ø 34 / 5 x 268	05.397.58.03.0			
367	Return spring (Retention spring)		03.397.33.12.0 (Hook)			
368	Return spring (Retention spring)		03.397.33.13.0 (Eye)			

* not available loose - see repair kit brake lining (item 349)

4 Brake parts

4.2 Brake with split roller (BPW 95) (Manufactured from 3/95) SN 3616 / 3620 BPW 95

K..

K

SN 3616 BPW 95

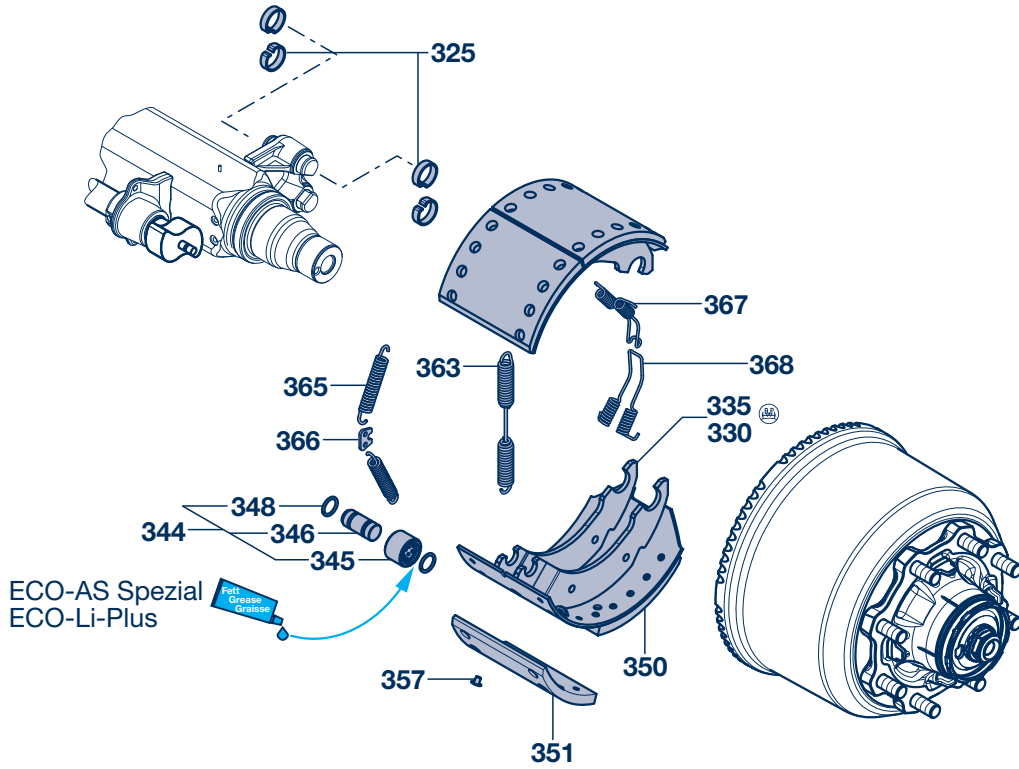

SN 3620 BPW 95

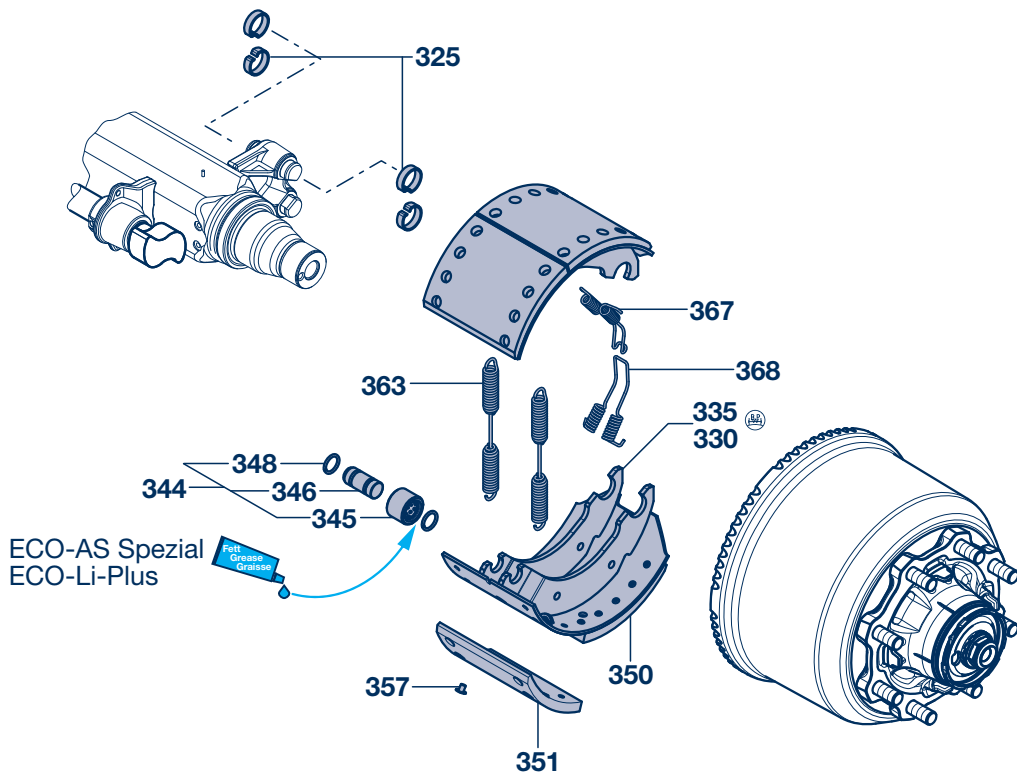

Brake parts 4

K.. Brake with split roller (BPW 95) (Manufactured from 3/95) 4.2

SN 3616 / 3620 BPW 95

Item	Designation	Dimension	BPW Code no.			
			SN 3616 ---.551.---		SN 3620 ---.552.---	
325	'C' Clip		03.188.02.02.0			
327	Repair kit brake, without brake shoes (item 325, 363 - 368)	(for 1 axle)	09.801.06.82.0		09.801.06.81.0	
328	Repair kit brake, with brake shoes (item 327, 330)	(for 1 axle)	09.801.02.41.0		09.801.02.40.0	
330	Brake shoe assembly, with lining, (incl. item 345 - 357)		05.091.19.24.1		05.091.19.22.1	
335	Brake shoe assembly, without lining, (incl. item 345 - 348)		05.091.19.33.0		05.091.19.34.0	
344	Repair kit brake shoe roller (item 345 - 348)		09.801.02.91.0 (for 1 axle side)			
345	Roller	Ø 26 / 45 x 33.5	05.331.44.02.0			
346	Bolt	Ø 26 x 58.5	03.084.75.24.0			
348	Ring	Ø 24 / 31 / 3.5	03.310.70.15.0			
349	Repair kit brake lining (for 1 axle, item 350 (4x) + 351 (4x))	18 mm	-		09.801.08.04.0	
			Brake pin side 10 Rivets item 350	Camshaft side 8 Rivets item 351	Brake pin side 10 Rivets item 350	Camshaft side 8 Rivets item 351
350 / 351	Brake lining (Textar T090)	18 mm	03.092.19.63.0	03.092.19.62.0	03.092. *	03.092. *
		19 mm	03.092.19.64.0	03.092.19.55.0	03.092.19.56.0	03.092.19.57.0
		19.5 mm	03.092.19.66.0	03.092.19.67.0	03.092.19.58.0	03.092.19.59.0
357	Rivet (Steel)	B 8 x 15 / 7338	02.5805.80.35			
363	Return spring	Ø 24.5 / 4 x 236	05.397.46.13.0			
365	Return spring	Ø 22 / 4 x 119	03.397.44.10.0		-	
366	Plate		03.285.22.05.0		-	
367	Return spring (Retention spring)		03.397.33.12.0 (Hook)			
368	Return spring (Retention spring)		03.397.33.13.0 (Eye)			

* not available loose - see repair kit brake lining (item 349)

4 Brake parts

4.2 Brake with split roller (BPW 95) (Manufactured from 3/95) SN 3015 / 3020 BPW 95

N..

N

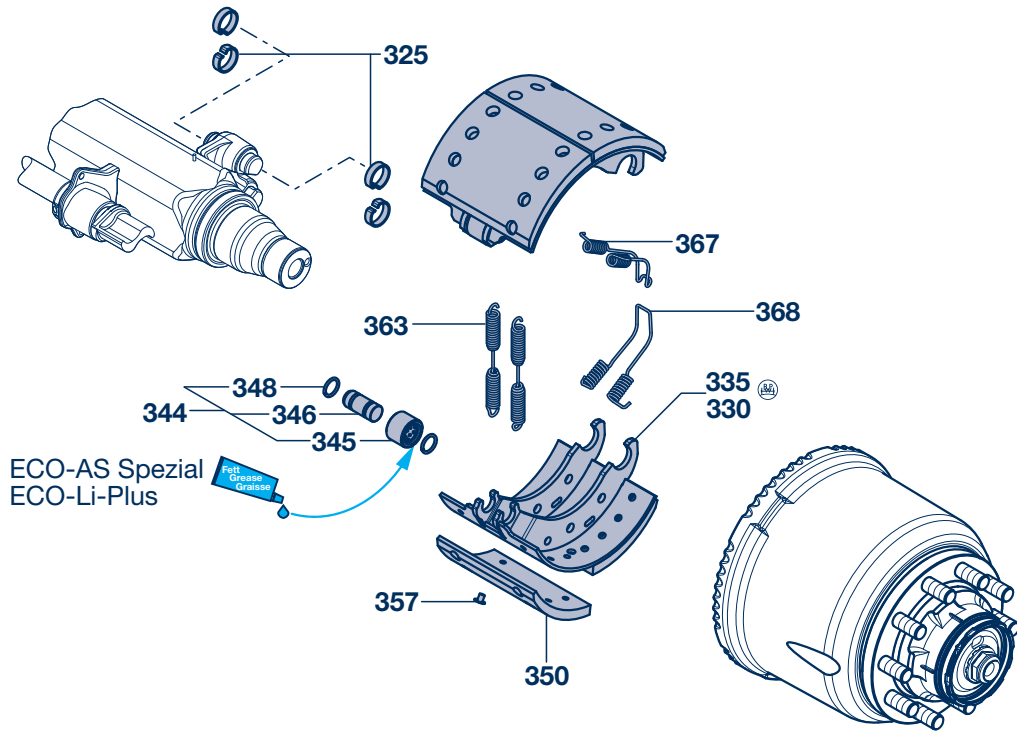

Brake parts 4

N.. Brake with split roller (BPW 95) (Manufactured from 3/95) 4.2

SN 3015 / 3020 BPW 95

Item	Designation	Dimension	BPW Code no.	
			SN 3015 ---.501.---	SN 3020 ---.502.---
325	'C' Clip		03.188.02.02.0	
327	Repair kit brake, without brake shoes (item 325, 363 - 368)	(for 1 axle)	09.801.06.80.0	
328	Repair kit brake, with brake shoes (item 327, 330)	(for 1 axle)	09.801.02.43.0	09.801.08.02.0
330	Brake shoe assembly, with lining, (incl. item 345 - 357)		05.091.15.05.1	05.091.14.77.1
335	Brake shoe assembly, without lining, (incl. item 345 - 348)		05.091.15.13.0	05.091.14.80.0
344	Repair kit brake shoe roller (item 345 - 348)		09.801.02.91.0 (for 1 axle side)	
345	Roller	Ø 26 / 45 x 33.5	05.331.44.02.0	
346	Bolt	Ø 26 x 58.5	03.084.75.24.0	
348	Ring	Ø 24 / 31 / 3.5	03.310.70.15.0	
350	Brake lining (Textar T090)	18 mm	03.092.13.44.0	03.092.14.45.0
		19 mm	03.092.13.45.0	03.092.14.46.0
		19.5 mm	03.092.13.46.0	03.092.14.47.0
357	Rivet (Steel)	B 8 x 15 / 7338	02.5805.80.35	
363	Return spring	Ø 20 / 3.6 x 180	05.397.34.17.0	
367	Return spring (Retention spring)		03.397.33.08.0 (Hook)	
368	Return spring (Retention spring)		03.397.33.09.0 (Eye)	

* not available loose - see repair kit brake lining (item 349)

N

4 Brake parts

4.3 Brake drums

SN 42..		H.. / R..			
Item	Designation (Remark)	BPW Code no.		Dimension	
380	Brake drum				
	Brake type	Ø 420 x 120	Ø 420 x 180	Ø 420 x 200	Ø 420 x 220
	Brake designation	---.741.---	---.710.---	---.718.---	---.739.---
		---.790.---	---.714.---	---.723.---	---.745.---
		---.794.---	---.743.---	---.744.---	
		B	B	B	B
D 290 / TK 335 / 6 x Ø21					
	HB.. / HI.. / HX..	03.106.97.16.0 197	03.109.67.17.0 226	03.109.77.13.0 260	-
		-	03.109.67.01.0 252	03.109.77.03.0 287	-
	HIZ. / HXZ..	-	03.109.67.17.0 226	03.109.77.41.0 ¹⁾ 247	03.106.87.16.0 265
D 230 / TK 275 / 8 x Ø21					
	HS.. / HZ.. / HZD..	03.106.95.16.0 197	03.106.65.08.0 252	-	-
D 230 / TK 275 / 8 x Ø23					
	HS.. ECO / ECO-MAXX	03.109.73.02.0 197	-	-	-
D 240 / TK 285 / 8 x Ø20					
	HZ.. Japanese	-	-	-	03.109.87.03.0 294
D 240 / TK 285 / 8 x Ø21					
	HZ.. Japanese	-	03.109.67.05.0 252	03.109.77.28.0 287	-
		-	-	03.106.79.06.0 287 *	-
D 240 / TK 285 / 10 x Ø21					
	HZ.. Japanese	-	03.109.67.06.0 252	03.109.77.02.0 287	-
D 290 / TK 335 / 10 x Ø23					
	HS..	-	03.109.67.13.0 226	03.109.77.16.0 260	-
	HS.. MAXX / ECO MAXX / ECO^{Plus} / ECO Plus 2	03.109.73.01.0 197	03.109.67.79.0 ¹⁾ 226	03.109.77.42.0 ¹⁾ 259	-
		-	03.109.67.77.0 ¹⁾ 226 *	-	-
	HZ.. MAXX / ECO MAXX / ECO^{Plus} / ECO Plus 2	-	03.109.67.78.0 ¹⁾ 249	03.109.77.43.0 ¹⁾ 284	-
	HS.. / HZ..	03.106.97.17.0 197	03.109.67.74.0 252	03.109.77.44.0 ¹⁾ 287	03.109.87.01.0 294
	HZ.. Japanese	-	-	03.106.79.08.0 287	-
	HZ.. for rim 14.00-20	-	-	03.106.77.61.0 287	-
	HZ.. MAXX for rim 14.00-20	-	-	03.109.77.23.0 284	-
	HZ.. 14010-1	-	-	03.106.77.59.0 297	-
		-	-	03.109.77.46.0 ¹⁾ 297 *	-
	HZ.. 14010-1 MAXX	-	-	03.109.77.21.0 294	-
		-	-	03.109.77.22.0 294 *	-
	HZ.. / HZD..	03.106.97.17.0 197	03.106.67.55.0 252 *	03.109.77.45.0 ¹⁾ 287 *	-
		-	-	03.109.77.47.0 ¹⁾ 287 *	-
	Max. diameter permissible after machining Ø mm	423	423	423	423
	Max. utilisation Ø mm	424	424	424	424

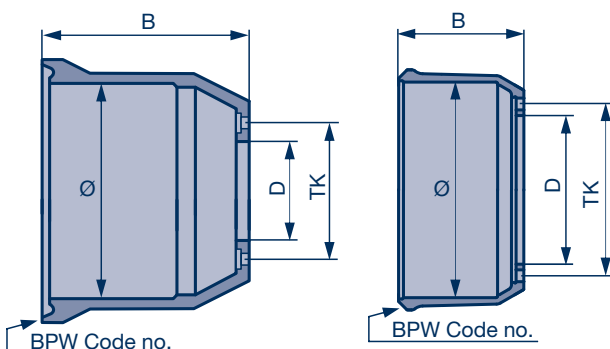

B = overall width

* = ribbed

¹⁾ = ECO Drum

03.109.... = ECO brake drum with integrated wear indicator

Brake parts 4

Brake drums 4.3

SN 36..				K..	
Item	Designation (Remark)	BPW Code no.	Dimension		
380	Brake drum				
	Brake type	Ø 360 x 160	Ø 360 x 200		
	Brake designation	---,--,542,--- ---,--,551,---	---,--,546,--- ---,--,552,---	B	B
	D 230 / TK 275 / 8 x Ø23 / 2 x Ø11				
	KRBM.. 6408 30.65.542....	03.105.90.05.0	221	-	
	D 230 / TK 275 / 8 x Ø23				
	KRB.. 30.06.542....	03.105.90.09.0	328	-	
	D 230 / TK 275 / 8 x Ø23				
	K.. ECO-MAXX / ECO^{Plus} / ECO Plus 2	-	03.109.90.03.0	260	
		-	03.109.90.22.0	263	
	D 190 / TK 225 / 10 x Ø23				
	K.. ECO-MAXX / ECO^{Plus} / ECO Plus 2	-	03.109.90.04.0	260	
	K.. (13t)	-	03.109.90.24.0	263	
	D 290 / TK 335 / 10 x Ø23				
	KHS.. 9010/3 30.38.551....	03.109.92.01.0	205	-	
	KHS.. 9010/3 / 11010/3	-	03.109.90.02.0	263	
	Max. diameter permissible after machining Ø mm	363		363	
	Max. utilisation Ø mm	364		364	

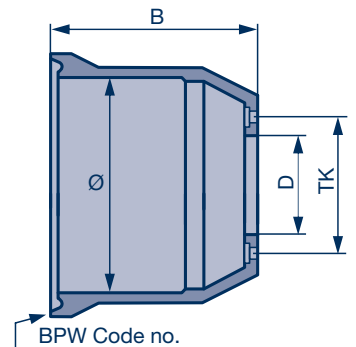

SN 30..				N..	
Item	Designation (Remark)	BPW Code no.	Dimension		
380	Brake drum				
	Brake type	Ø 300 x 150	Ø 300 x 200		
	Brake designation	---,--,582,--- ---,--,592,--- ---,--,501,---	---,--,586,--- ---,--,596,--- ---,--,502,---	B	B
	D 165 / TK 205 / 6 x Ø 21				
	N..	03.105.34.08.0	210	-	
	D 165 / TK 205 / 6 x Ø23 / 2 x Ø11				
	N.. 12" Tyre	03.105.34.09.0	345 ¹⁾	-	
	D 190 / TK 230 / 6 x Ø21				
	N..IZ / N..XZ	03.105.34.10.0	210	03.105.47.05.0	255
	D 200 / TK 240 / 6 x Ø21 / 2 x Ø13				
	N..IZ / N..XZ 13t	-		03.105.48.02.0	255
	D 230 / TK 275 / 8 x Ø21 / 2 x Ø11				
	N.. 8 holes	03.105.38.03.0	210	03.105.49.03.0	295
		03.105.38.01.0	328	-	
	D 230 / TK 275 / 8 x Ø23				
	N.. 8 holes	03.105.38.05.0	212	-	
	D 185 / TK 225 / 10 x Ø23 / 2 x Ø13				
	N.. 13t 10 holes	-		03.105.46.25.0	265
		-		03.105.46.27.0	315
	D 190 / TK 225 / 10 x Ø23				
	N.. Conv. / ECO	03.105.36.12.0	210	03.105.46.22.0	245
		-		03.109.46.49.0	260
		-		03.109.46.40.0	295
	N.. ECO-MAXX / MAXX	03.109.44.02.0	210	03.109.46.06.0	260
	Max. diameter permissible after machining Ø mm	303		303	
	Max. utilisation Ø mm	304		304	

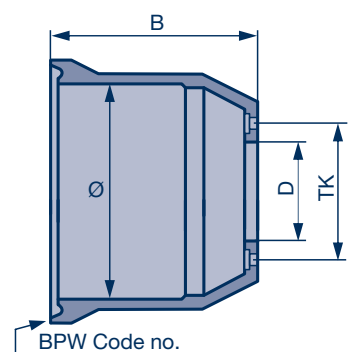

¹⁾ + Cylinder peg for wheel stud bolt securing 4 x 16 / 1472, BPW Code no. 02.6004.06.01

4 Brake parts

4.4 Brake drum attachments

Item	Designation	BPW Code no.	Dimension	
HB..				
390	Bolt assembly (incl. item 391 + 392)	05.865.03.12.0	M 20 x 55 - 8.8	
391	Spring washer	02.5601.20.90	A 20 / 128	
392	Hexagon nut	02.5202.24.80	M 20 / 934	
HI.. / HIZ..				
390	Bolt assembly (incl. item 392)	05.865.03.02.0	M 20 x 45 - 10.9	
392	Hexagon nut	03.260.03.12.0	M 20-10 / SW 30	
KRBM.. 6408				
390	Locking bolt	02.5070.63.02	M 10 x 25	

Brake parts 4

Brake drum attachments 4.4

Item	Designation	BPW Code no.	Dimension	
NR.. 6006 12" and NR.. 8 holes				
390	Locking bolt	02.5070.63.00	M 10 x 25	
NR 13t..				
390	Countersunk bolt	02.5041.30.82	M 12 x 25 / 7991 - 4.8	

N

4 Brake parts

4.5 Dust covers

SN 42..

H.. / R..

SN 42..

H.. / R..

H

Dust covers available as sets (upper + lower)

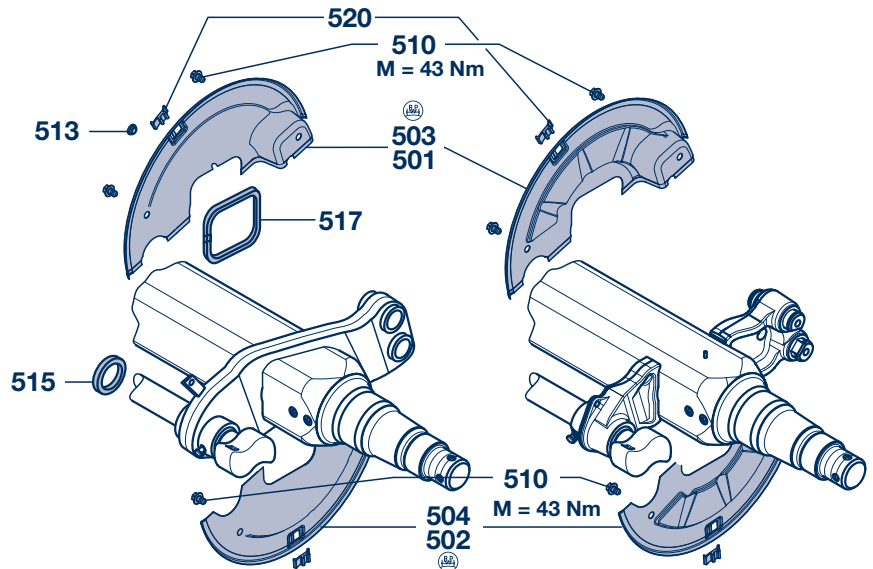
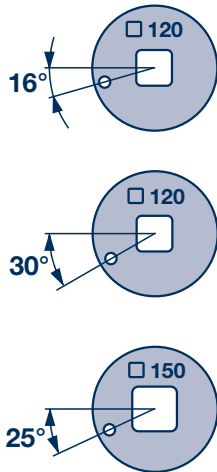
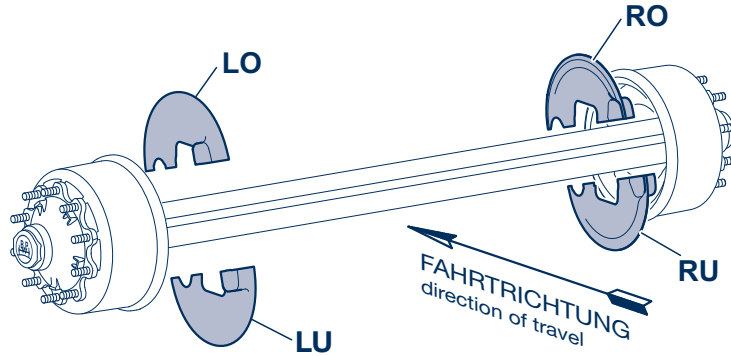

BPW 95 / ECO Drum

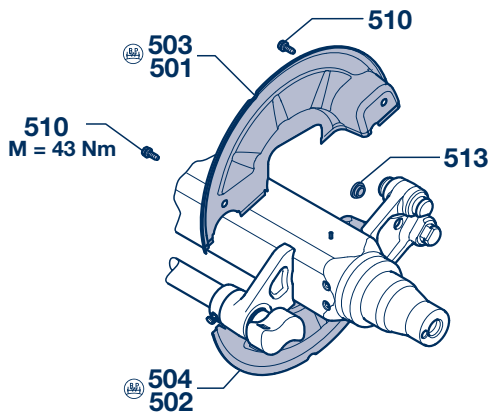

ECO Drum - dust covers / old axle beam (attachment with locking bolts)

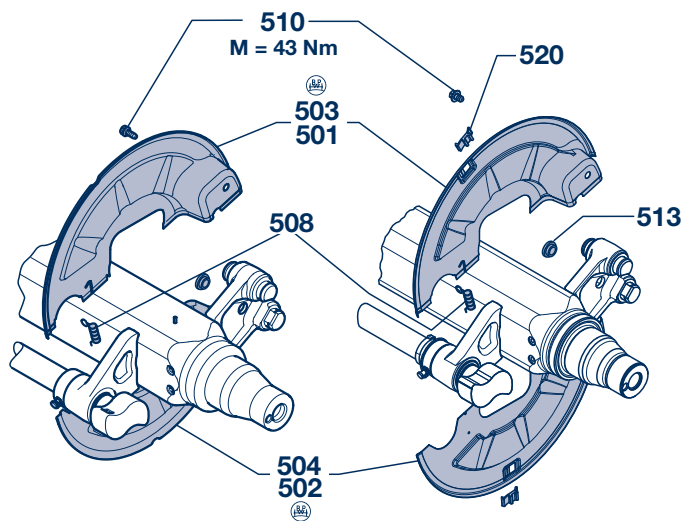

ECO Drum - dust covers / ECO Drum - axle beam (attachment with shouldered bolts + return spring)

Brake parts 4

Dust covers 4.5

SN 42..

H.. / R..

SN 42..		H.. / R..				
Item	Designation (Remark)	BPW Code no.				
500 - 504	Brake designation	item 500	item 501	item 502	item 503	item 504
	Axle type	Set of dust covers cpl.	Dust cover left upper (LO)	Dust cover left lower (LU)	Dust cover right upper (RO)	Dust cover right lower (RU)
	Axle beam	item 501 - 520				
	Brake position					
SN 4212-2		---.790.--- / ---.794.---				
H..	<input type="checkbox"/> 120 30°	99.00.000.0.70	03.010.98.53.0	03.010.98.24.0	03.010.98.54.0	03.010.98.25.0
H..	<input type="checkbox"/> 120 16°	99.00.000.0.87	03.010.99.38.0	03.010.99.37.0	03.010.99.40.0	03.010.99.39.0
SN 4212 BPW 95		---.741.---				
H..	<input type="checkbox"/> 120 16°	-	03.010.91.32.0	03.010.91.31.0	03.010.91.34.0	03.010.91.33.0
SN 4218-2		---.710.--- / ---.714.---				
H..	<input type="checkbox"/> 120 30°	99.00.000.0.71	03.010.98.45.1	03.010.98.08.0	03.010.98.46.1	03.010.98.09.0
H..	<input type="checkbox"/> 120 16°	99.00.000.0.88	03.010.99.34.0	03.010.99.33.0	03.010.99.36.0	03.010.99.35.0
H..	<input type="checkbox"/> 150 25°	99.00.000.0.80	03.010.98.91.0	03.010.98.12.0	03.010.98.92.0	03.010.98.13.0
R..	<input type="checkbox"/> 127 30°	99.00.000.0.72	03.010.98.69.0	03.010.98.06.0	03.010.98.70.0	03.010.98.05.0
SN 4218 BPW 95 / ECO Drum		---.743.---				
H..	<input type="checkbox"/> 120 16°	99.00.000.1.29 ¹⁾	03.010.99.59.0	03.010.99.60.0	03.010.99.57.0	03.010.99.58.0
		99.00.000.1.23 ²⁾	03.010.71.93.0	03.010.71.94.0	03.010.71.91.0	03.010.71.92.0
H..	<input type="checkbox"/> 120 30°	99.00.000.1.28 ¹⁾	03.010.99.93.0	03.010.99.94.0	03.010.99.91.0	03.010.99.92.0
H..	<input type="checkbox"/> 150 25°	99.00.000.1.30 ¹⁾	03.010.99.67.0	03.010.99.68.0	03.010.99.65.0	03.010.99.66.0
		99.00.000.1.24 ²⁾	03.010.71.87.0	03.010.71.86.0	03.010.71.85.0	03.010.71.84.0
R..	<input type="checkbox"/> 127 30°	99.00.000.1.21 ¹⁾	03.010.99.75.0	03.010.99.73.0	03.010.99.73.0	03.010.99.75.0
SN 4220-2		---.718.--- / ---.723.---				
H..	<input type="checkbox"/> 120 30°	99.00.000.0.75	03.010.98.51.1	03.010.98.16.0	03.010.98.52.1	03.010.98.17.0
H..	<input type="checkbox"/> 120 16°	99.00.000.0.89	03.010.99.42.0	03.010.99.41.0	03.010.99.44.0	03.010.99.43.0
H..	<input type="checkbox"/> 150 25°	99.00.000.0.73	03.010.98.47.1	03.010.97.94.0	03.010.98.48.1	03.010.97.95.0
R..	<input type="checkbox"/> 127 30°	99.00.000.0.85	03.010.98.65.0	03.010.97.98.0	03.010.98.66.0	03.010.97.97.0
SN 4220 BPW 95 / ECO Drum		---.744.---				
H..	<input type="checkbox"/> 120 16°	99.00.000.1.31 ¹⁾	03.010.99.55.0	03.010.99.56.0	03.010.99.53.0	03.010.99.54.0
		99.00.000.1.25 ²⁾	03.010.81.15.0	03.010.81.16.0	03.010.81.13.0	03.010.81.14.0
H..	<input type="checkbox"/> 120 30°	99.00.000.1.27 ¹⁾	03.010.91.37.0	03.010.91.38.0	03.010.91.35.0	03.010.91.36.0
H..	<input type="checkbox"/> 150 25°	99.00.000.1.32 ¹⁾	03.010.99.63.0	03.010.99.64.0	03.010.99.61.0	03.010.99.62.0
		99.00.000.1.26 ²⁾	03.010.81.19.0	03.010.81.20.0	03.010.81.17.0	03.010.81.18.0
R..	<input type="checkbox"/> 127 30°	99.00.000.1.22 ¹⁾	03.010.99.71.0	03.010.99.69.0	03.010.99.69.0	03.010.99.71.0
SN 4222-1 / 4222-2		---.839.--- / ---.739.---				
H..	<input type="checkbox"/> 150 25°	99.00.000.0.76	05.010.98.49.1	05.010.98.20.0	05.010.98.50.1	05.010.98.21.0
SN 4222 BPW 95		---.745.---				
H..	<input type="checkbox"/> 150 25°	99.00.000.1.34	03.010.81.43.0	03.010.81.44.0	03.010.81.41.0	03.010.81.42.0

¹⁾ ECO Drum - dust covers / old axle beam (attachment with locking bolts)

²⁾ ECO Drum - dust covers / ECO Drum - axle beam (attachment with shouldered bolts + return spring)

Item	Designation (Remark)	BPW Code no.	Dimension	
508	Return spring ⁴⁾	03.397.11.02.0		³⁾ not necessary with brake position 16° ⁴⁾ for ECO Drum
510	Locking bolt	02.5071.22.00	M 10 x 15	
		02.5070.83.00	M 10 x 20	
	Shouldered bolt ⁴⁾	02.5071.55.80	M 10 x 1.5 x 15	
513	Plug (without ABS)	02.3704.33.00	Ø 10.7	
		02.3704.57.00	Ø 22	
	Seal (with ABS)	02.5681.78.00	Ø 6 / 10 / 13	
515	Seal ³⁾	03.120.23.06.0	Ø 52 / 68 / 8	
517	Seal ³⁾	<input type="checkbox"/> 120 / <input type="checkbox"/> 127	L = 340, <input type="checkbox"/> 8	
		<input type="checkbox"/> 150	L = 450, <input type="checkbox"/> 8	
520	Plug	03.379.00.23.0		

4 Brake parts

4.5 Dust covers

SN 3620 / 3020

K.. / N..

K
N

Dust covers available as sets (upper + lower)

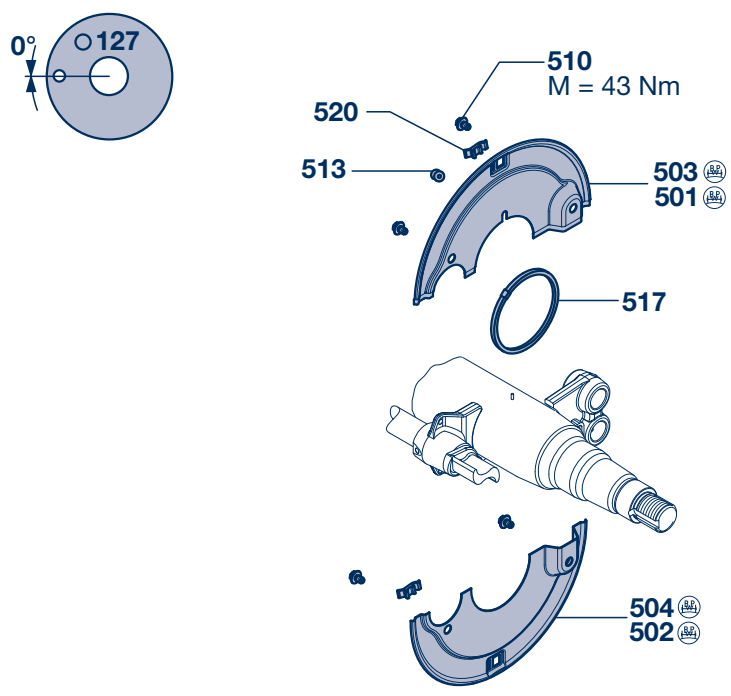
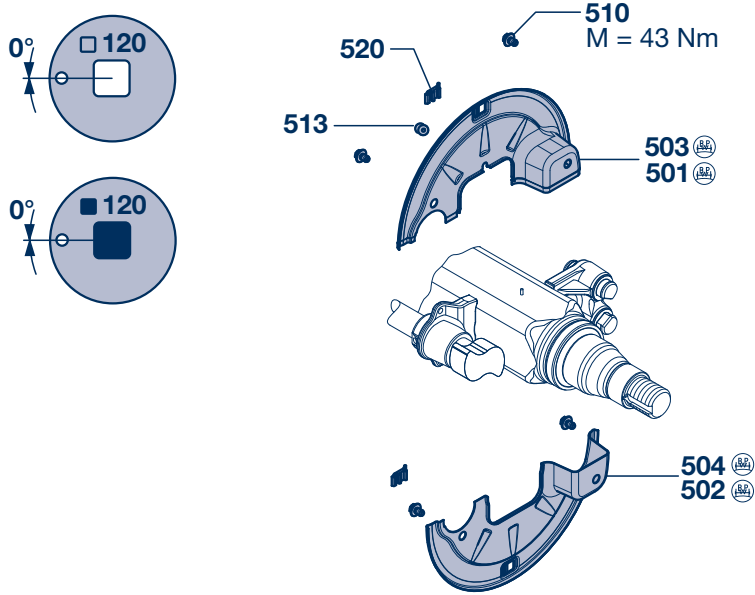

Brake parts 4**Dust covers 4.5****SN 3620 / 3020****K.. / N..**

SN 36..							K..
Item	Designation (Remark)	BPW Code no.					
500 - 504	Brake designation Axle type Axle beam	item 500 Set of dust covers cpl. Item 501 - 520	item 501 Dust cover left upper	item 502 Dust cover left lower	item 503 Dust cover right upper	item 504 Dust cover right lower	
SN 3616							---.---.542.---
KR..	○ 127	99.00.000.0.81	03.010.96.53.0	03.010.96.50.0	03.010.96.52.0	03.010.96.51.0	
KM..	■ 120	99.00.000.1.08	03.010.91.10.0	03.010.91.09.0	03.010.91.12.0	03.010.91.11.0	
SN 3616 BPW 95							---.---.551.---
KH..	□ 120	99.00.000.1.06	03.010.99.79.0	03.010.99.80.0	03.010.99.77.0	03.010.99.78.0	
SN 3620							---.---.546.---
KR..	○ 127	99.00.000.0.81	03.010.96.53.0	03.010.96.50.0	03.010.96.52.0	03.010.96.51.0	
KH.. / KM..	□ 120 / ■ 120	99.00.000.0.83	03.010.96.67.0	03.010.96.68.0	03.010.96.70.0	03.010.96.69.0	
SN 3620 BPW 95							---.---.552.---
KR..	○ 127	99.00.000.0.81	03.010.96.53.0	03.010.96.50.0	03.010.96.52.0	03.010.96.51.0	
KH.. / KM..	□ 120 / ■ 120	99.00.000.1.06	03.010.99.79.0	03.010.99.80.0	03.010.99.77.0	03.010.99.78.0	
SN 30..							N..
Item	Designation (Remark)	BPW Code no.					
500 - 504	Brake designation Axle type Axle beam	item 500 Set of dust covers cpl. item 501 - 520	item 501 Dust cover left upper	item 502 Dust cover left lower	item 503 Dust cover right upper	item 504 Dust cover right lower	
SN 3015-1							---.---.582.---
NR..	○ 127	99.00.000.1.00	03.010.96.48.0	03.010.96.40.0	03.010.96.49.0	03.010.96.41.0	
SN 3015							---.---.592.---
NR..	○ 127	99.00.000.1.01	03.010.96.84.0	03.010.96.83.0	03.010.96.85.0	03.010.96.86.0	
NH..	□ 120	99.00.000.1.02	03.010.91.08.0	03.010.91.07.0	03.010.91.06.0	03.010.91.05.0	
SN 3015 BPW 95							---.---.501.---
NH..	□ 120	-	03.010.99.83.0	03.010.99.84.0	03.010.99.81.0	03.010.99.82.0	
SN 3020-1							---.---.586.---
NR..	○ 127	99.00.000.1.03	03.010.96.33.0	03.010.96.20.0	03.010.96.32.0	03.010.96.21.0	
SN 3020							---.---.596.---
NR..	○ 127	99.00.000.0.84	03.010.96.80.0	03.010.96.79.0	03.010.96.82.0	03.010.96.81.0	
NH..	□ 120	99.00.000.1.05	03.010.91.02.0	03.010.91.01.0	03.010.91.03.0	03.010.91.04.0	
SN 3020 BPW 95							---.---.502.---
NH..	□ 120	99.00.000.1.09	03.010.99.87.0	03.010.99.88.0	03.010.99.85.0	03.010.99.86.0	
Item	Designation (Remark)	BPW Code no.	Dimension				
510	Locking bolt	02.5071.22.00	M 10 x 15		1) not with BPW 95 / ECO Drum		
		02.5070.83.00	M 10 x 20				
513	Plug (without ABS) Seal (with ABS)	02.3704.33.00	Ø 10.7				
		02.5681.78.00	Ø 6 / 10 / 13				
517	Seal 1) □ 120 / ○ 127	05.121.30.06.0	L = 340, □ 8				
520	Plug	03.379.00.23.0					

4 Brake parts

4.6 Brake cylinders

Diaphragm cylinders

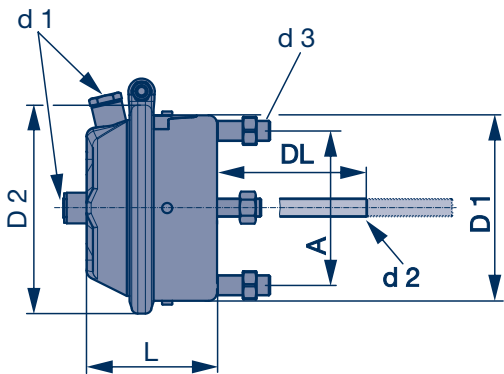

Brake cylinder set incl. yoke with round hole
BPW Code no.: 05.444.xx.xx.1

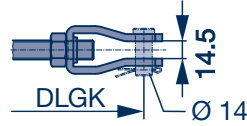

Pre-assembled spring-type cylinder, ready for installation

Yoke head loose:
BPW Code no.:
M 16 x 1.5 05.171.03.34.0
5/8"-18 UNF 05.171.03.37.0

Brake cylinder set incl. yoke with elongated hole
BPW Code no.: 05.444.xx.xx.2

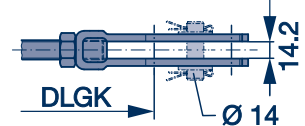

Only for diaphragm cylinder version

Yoke head loose:
BPW Code no.:
M 16 x 1.5 05.171.04.10.0

Brake cylinder size	BPW Code no.	Air connection thread d 1	Push rod thread d 2	Fitting bolts thread d 3	L (mm)	D 1 (mm)	D 2 (mm)	A (mm) Connection dimension	DL (mm) without yoke	DLGK (mm) with yoke
9"	02.0327.98.00		M 12 x 1.5		108	112	135	76.2	186	227
12"	02.0327.99.00		M 12 x 1.5		114	123	144	76.2	186	227
16"	05.444.13.01.0		M 16 x 1.5		120	145	165	120.7	185	227
20"	05.444.14.01.0		M 16 x 1.5		120	151	180	120.7	185	227
	05.444.14.02.0	3/8"-18 NPTF	5/8"-18 UNF							
24"	05.444.15.01.0		M 16 x 1.5		120	162	190	120.7	185	227
	05.444.15.02.0	3/8"-18 NPTF	5/8"-18 UNF							
	05.444.15.04.0 ¹⁾		M 16 x 1.5							
	05.444.15.10.0		M 16 x 1.5	142					184	
	05.444.15.11.0		M 16 x 1.5	170					212	
30"	05.444.16.01.0		M 16 x 1.5		125	178	215	120.7	185	227
	05.444.16.02.0	3/8"-18 NPTF	5/8"-18 UNF							
	05.444.16.04.0 ¹⁾		M 16 x 1.5							
	05.444.16.05.0	1/2" NPTF	5/8"-18 UNF	142					184	
	05.444.16.10.0		M 16 x 1.5	170					212	
	05.444.16.11.0		M 16 x 1.5							
36"	05.444.17.01.0		M 16 x 1.5		135	201	225	120.7	185	227
	05.444.17.02.0	3/8"-18 NPTF	5/8"-18 UNF							

¹⁾ Air connection turned on 90°

Attachment nuts for brake cylinder

Thread	BPW Code no.
M 16 x 1.5	02.5202.21.80
5/8"-18 UNF	02.5202.80.00

Brake parts 4

Brake cylinders 4.6

Diaphragm-diagram (M-M) cylinders

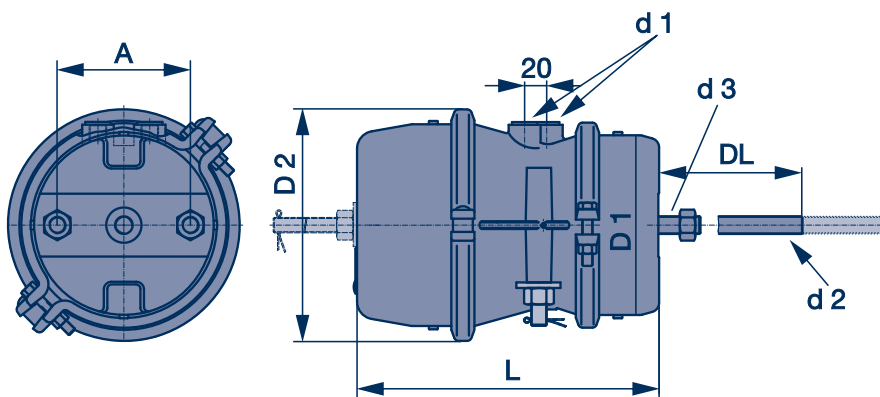

Brake cylinder set incl. yoke with round hole
BPW Code no.: 05.444.xx.xx.1

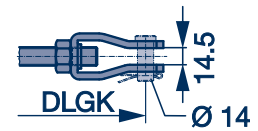

Pre-assembled spring-type cylinder, ready for installation

Yoke head loose:

BPW Code no.:

M 16 x 1.5 05.171.03.34.0

5/8"-18 UNF 05.171.03.37.0

Brake cylinder size	BPW Code no.	Air connection thread d 1	Push rod thread d 2	Fitting bolts thread d 3	L (mm)	D 1 (mm)	D 2 (mm)	A (mm) Connection dimension	DL (mm) without yoke	DLGK (mm) with yoke
16 / 24"	05.444.18.01.0	M 16 x 1.5			232	145	185	120.7	185	227
20 / 30"	05.444.19.01.0	M 16 x 1.5			274	163	211	120.7	185	227
	05.444.19.02.0	3/8"-18 NPTF	5/8"-18 UNF							
24 / 30"	05.444.20.01.0	M 16 x 1.5			274	163	211	120.7	185	227
	05.444.20.02.0	3/8"-18 NPTF	5/8"-18 UNF							
	05.444.20.04.0 ¹⁾	M 16 x 1.5								
	05.444.20.10.0	M 16 x 1.5							142	184
	05.444.20.11.0	M 16 x 1.5							170	212
30 / 30"	05.444.21.01.0	M 16 x 1.5			274	185	211	120.7	185	227
	05.444.21.02.0	3/8"-18 NPTF	5/8"-18 UNF							
	05.444.21.04.0 ¹⁾	M 16 x 1.5								
	05.444.21.05.0	1/2" NPTF	5/8"-18 UNF						142	184
	05.444.21.10.0	M 16 x 1.5							170	212
	05.444.21.11.0	M 16 x 1.5								

¹⁾ Air connection turned on 90°

Attachment nuts for brake cylinder

Thread	BPW Code no.
M 16 x 1.5	02.5202.21.80
5/8"-18 UNF	02.5202.80.00

H

K

N

5 Hubs, hub bearings

General

BPW hub bearings

Conventional hub bearing system

Until introduction of the ECO hub system, BPW supplied trailer axles with conventional hub bearings.

In this hub bearing, the 2 sealing rings are mounted on the stepped thrust washer (oil seals are used in the N.. axle series).

A pulling device is required to pull off the complete hub unit, the tapered inner roller bearing race as well as the thrust washer and seal assembly.

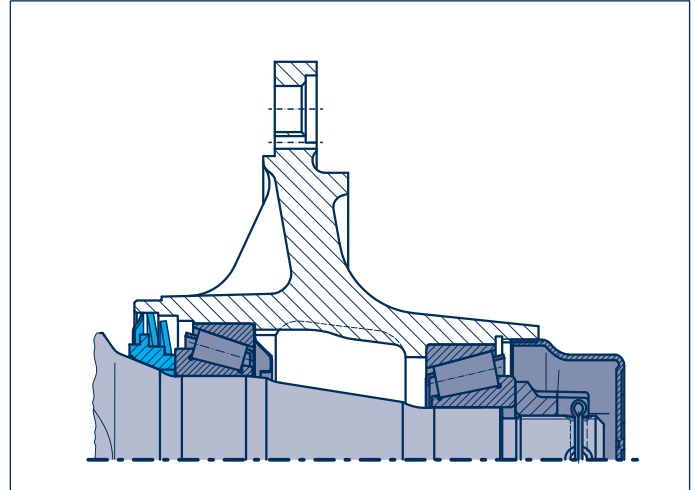

ECO hub bearing system

Dismantling the patented BPW ECO hub system (European patent 0 407 719 B1) couldn't be simpler:

In only a few operations, the wheel (complete with the hub, roller bearings and brake drum) is removed using the central threaded connection – just like wheel changes in motor racing.

The stepped bearing means there is no need to use a puller or other special tools.

The roller bearings remain in the hub where they are well protected against dirt and moisture.

Installation is also quick and easy: Box spanners are all that are required for the hub cap and axle nuts.

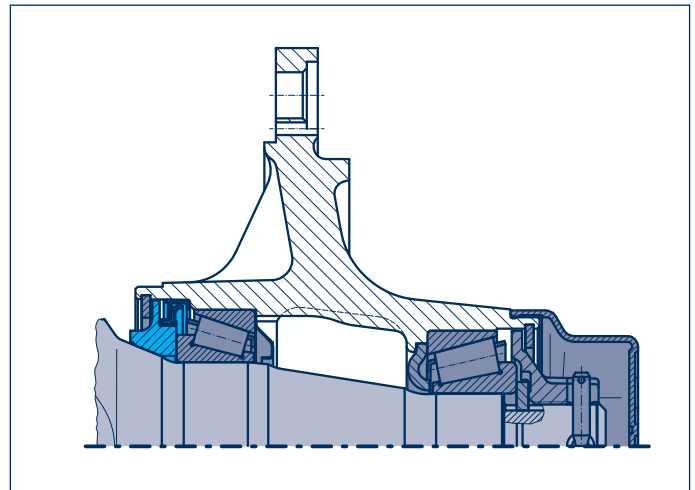

ECO^{Plus} hub bearing system

If you expect high mileages, rapid servicing and low maintenance costs from your axles, then only ECO^{Plus} will do.

Ground-breaking ECO^{Plus} bearing technology was developed on the basis of the special BPW ECO hub system.

The maintenance-free hub has an integrated multi-seal system for protecting the tapered roller bearings against dust and dirt.

A central threaded connection with integrated torque limiting function ensures the bearing preload is always optimum.

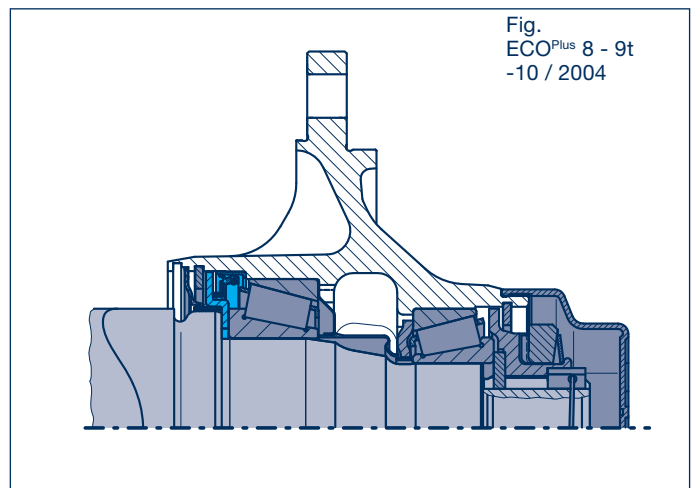

Hubs, hub bearings 5

General

Uniform axle stubs for all BPW trailer axles

As of January 1995 BPW axle beams and steering pivots will be converted to ECO axle stubs.

These differ from the conventional axle stubs by a keyway in the thread area.

A new axle nut and in addition a washer is used to fit the conventional bearing to ECO axle stubs.

Where spare axle beams and steering pivot assemblies are supplied, these are fitted throughout with these new axle nuts and washers.

If the ECO hub system is fitted, these parts are dispensed with.

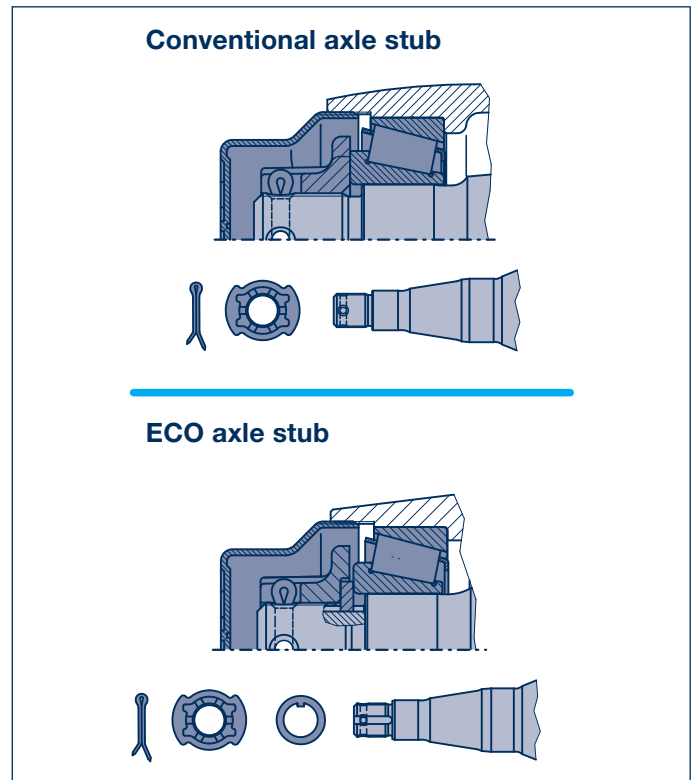

New seals for ECO^{Plus} hub bearing system

Starting in October 2004, BPW will be introducing the new ECO^{Seal} hub bearing sealing system.

With a larger dirt seal and new two stage dust seal, the proven concept of the ECO^{Plus} seal has clearly been further improved in a number of areas.

For example, the primary sealing lip is no longer fitted directly against the hub bearing, but instead fits against a special thrust race integrated into the seal assembly.

This new design enables the circumferential velocity of the seal to be significantly reduced, and with that, the amount of wear. In addition, the wheel bearing is provided with even better protection against dirt penetration by means of the covering dust and dirt sealing lips.

The seal wear ring remains in the hub when changing over to the new seal.

New ECO^{Plus} bearings are supplied without a race.

* The dirt seal is dropped for the ECO^{Seal} from 7 / 07.

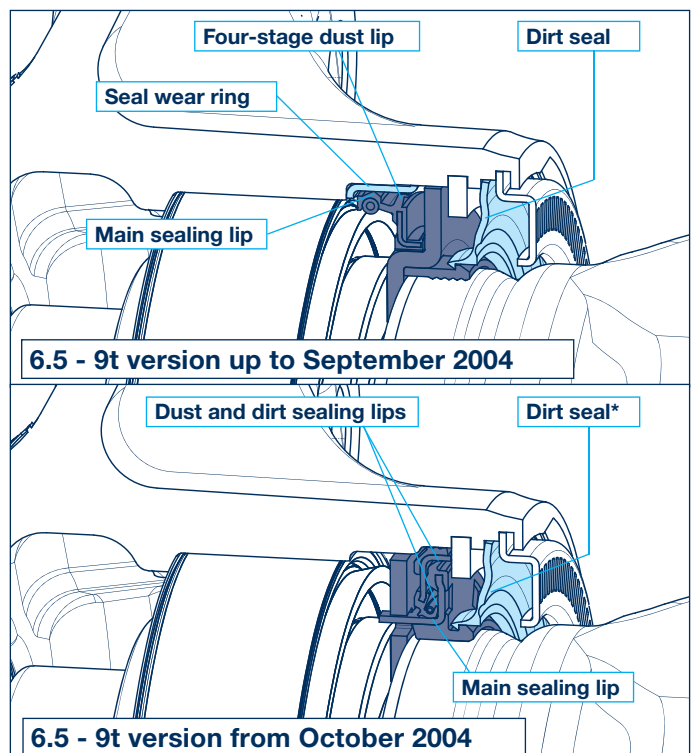

5 Hubs, hub bearings

General

ECO Plus 2 - the new generation of the tried and tested BPW ECO unit

The BPW ECO unit, proven a million times over in its ECO^{Plus} version, will be replaced from September 2007 by the still further improved, new ECO Plus 2 design.

A rigorous upgrade of the components has resulted in a significant weight reduction compared with the current ECO^{Plus} unit.

In the case of the ECO Plus 2 the hub cap has a bayonet fitting, enabling convenient fitting and removal of the hub cap.

Grease is supplied to the wheel bearings by means of a grease cartridge located between the bearings.

The axle nut previously used is replaced by an axle bolt with integrated torque limiter.

This product introduction affects all H, KH and NH ECO^{Plus} versions up to 9 tonnes axle load (drum-braked rigid and steering axles).

Advantages of ECO Plus 2:

- ⊙ In conjunction with the revised air suspension system there are significant weight-savings depending on the axle model:
Drum brake axle with ECO DRUM: 18 kg (SN 4218 see also BPW NEWS TB 7143709e)
- ⊙ Axle screw with torque limiter for optimum bearing adjustment
- ⊙ Simple greasing of the bearing by means of a grease cartridge
- ⊙ Existing approvals and homologations remain in force

You can still rely on the proven benefits of ECO^{Plus} bearings:

- ⊙ Encapsulated ECO bearing unit
- ⊙ 5+3 years ECO Plus warranty (on-road)
- ⊙ ECO system: Bearing removal according to the Formula 1 principle
- ⊙ Globally available DIN ISO taper roller bearings, which can be replaced individually, as can the seal elements

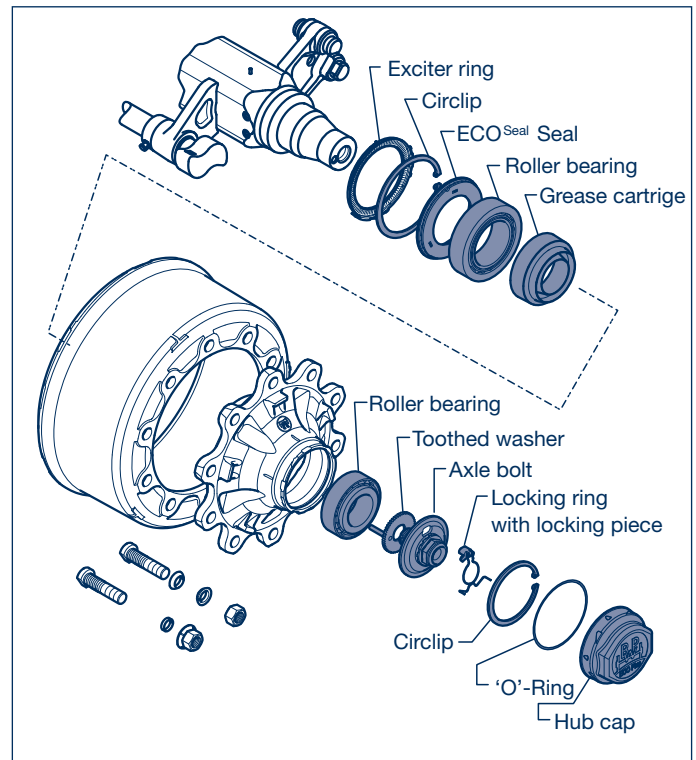
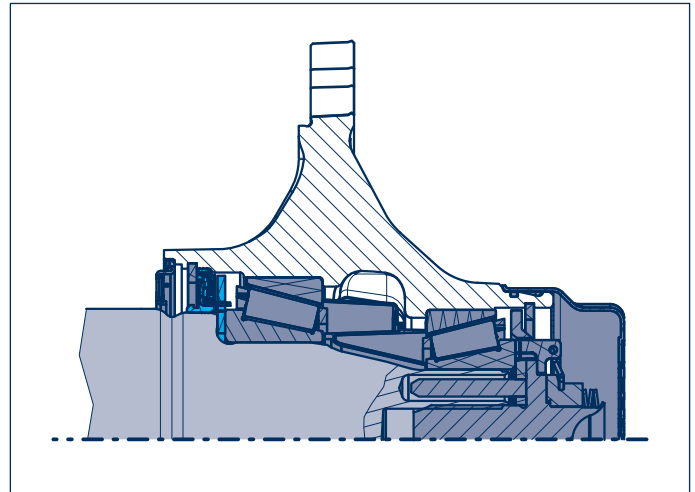

Hubs, hub bearings 5

General

Hub cap / ECOMETER

BPW trailer axles with the ECO Plus 2 unit have hub caps (and ECOMETERS) with a bayonet fitting.

The bayonet fitting replaces the previously usual threaded connection.

A 120 mm installation spanner (BPW part number 03.339.05.02.0, see also BPW tool catalogue) is needed for fitting or removing the new hub caps with the bayonet fitting.

 **An impact driver must not be used for fitting / removing hub caps or ECOMETERS with a bayonet fitting!**

Removal

To remove the hub cap it is turned anticlockwise through approx. 30 degrees with the installation spanner (Fig.).

When turned further, the hub cap lifts clearly away from the hub seat.

The released position is also indicated by markings on the hub cap and on the wheel hub (Fig. / Arrows).

In the released position the hub cap can be removed from the wheel hub by pulling it away.

Assembly

The seal between the hub cap and the wheel hub takes the form of an O-ring in the case of the ECO Plus 2 unit.

The O-ring is inserted in the groove on the hub collar of the wheel hub, and is to be replaced every time. The hub cap itself is to be given a thin coating of BPW ECO-Li^{Plus} special long-life grease inside in the area of the bayonet fitting, before assembly.

Corresponding markings in the hub cap and on the hub make it easier to fit the hub cap. The figure shows the hub cap in the correct position for fitting, with the spanner engaged. After been placed in position, the hub cap is pressed onto the hub and at the same time turned in clockwise direction. The hub cap is firmly in place when the position shown in Fig. (arrows) has been reached.

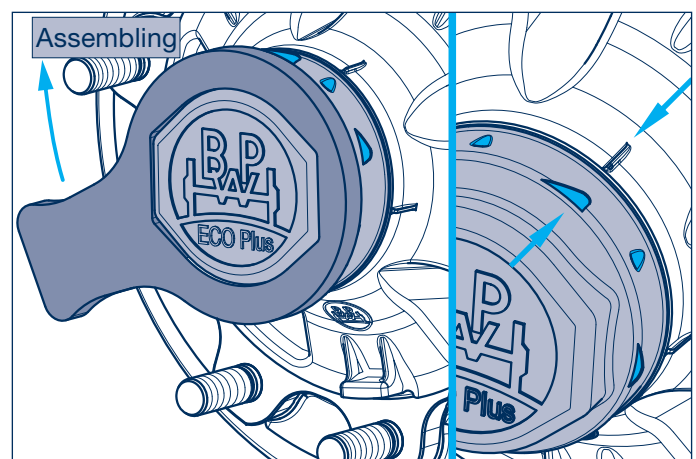
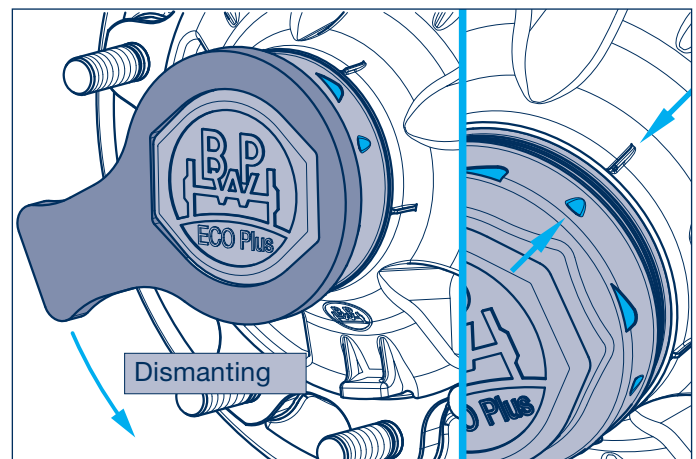
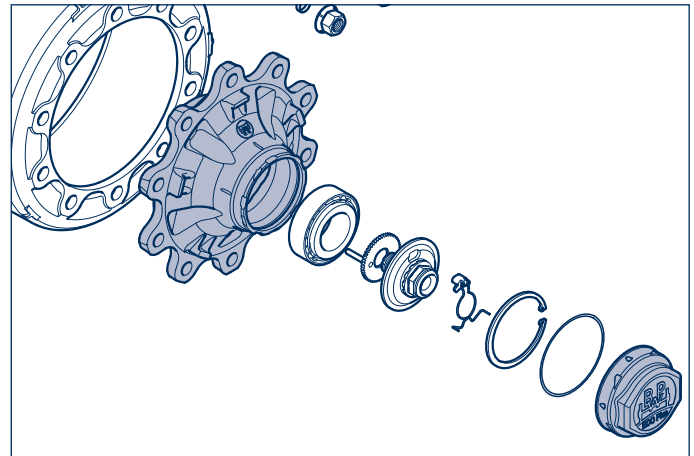

H

K

N

5 Hubs, hub bearings

5.1 Hub bearings

5.1.1 Conventional hub bearing system

H.. / K..

H
K

Sheet metal hub cap:
Thread pitch
2 mm M = 500 Nm
3 mm M = 700 Nm

Alloy hub cap:
Thread pitch
2 mm M = 350 Nm

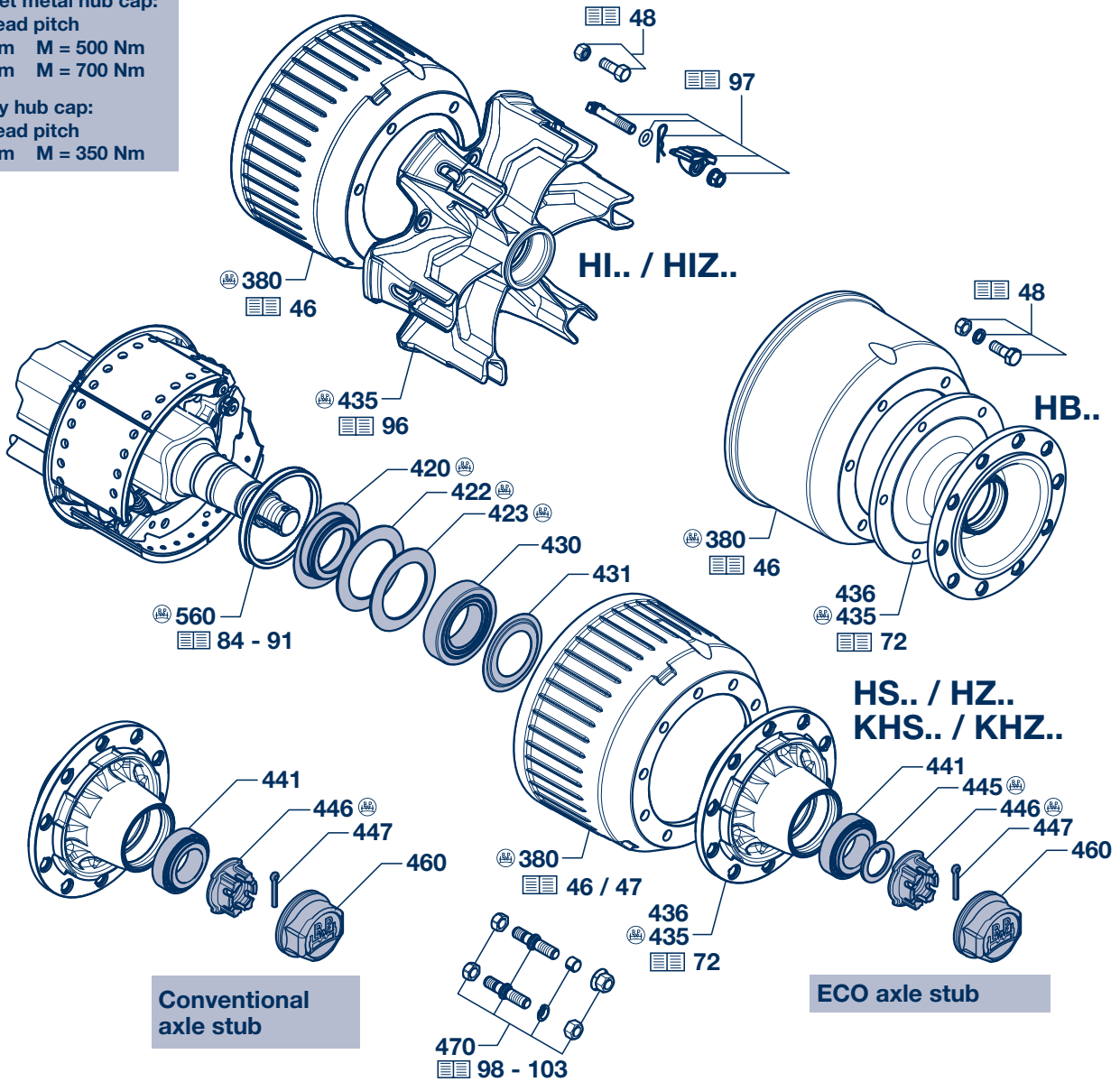

Grease filling, grease quantity and bearing adjustment see page 77

Hub caps with integrated Hubodometer see page 104 - 106

Uniform axle stubs for all BPW trailer axles

As of January 1995 BPW axle beams and steering pivots will be converted to ECO axle stubs. These differ from the conventional axle stubs by a keyway in the thread area.

A new axle nut (item 446) and in addition a washer (item 445) is used to fit the conventional bearing to ECO axle stubs.

Where spare axle beams and steering pivot assemblies are supplied, these are fitted throughout with these new axle nuts and washers.

If the ECO hub system is fitted, these parts are dispensed with.

Conventional axle stub

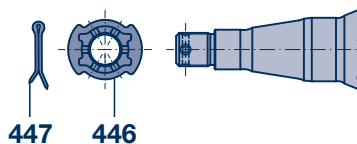
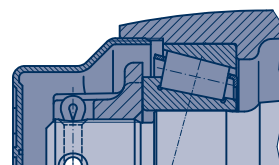

ECO axle stub

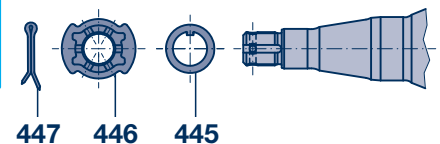
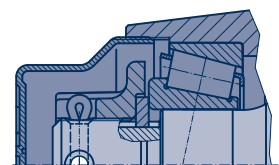

Hubs, hub bearings 5

Hub bearings 5.1

Conventional hub bearing system 5.1.1

H.. / K..

Item	Designation	BPW Code no.	Dimension	H.. / R..; K.. 6.5 - 9t -.06. / 08. / 09.----	H.. / R..; K.. 10 - 12t --.10.----
		KRBM 6408 --.65.----			
380	Brake drum	see page 47		see page 46 / 47	see page 46 / 47
418	Repair kit roller bearing, with thrust washer and hub cap (item 420 - 431, 441, 447, 460)	-		09.801.02.17.0 for 1 axle side	09.801.02.18.0 for 1 axle side
420	Thrust washer	05.370.06.11.0		05.370.06.48.0	05.370.07.43.0
422	Ring (Nylon)	03.310.97.14.0	Ø 105/141x2.5	03.310.97.31.0 Ø 110/141x2.5	03.310.98.21.0 Ø 128/165x2.5
423	Ring (Nylon)	03.310.97.13.0	Ø 100/134x2.5	03.310.97.32.0 Ø 104/136x2.5	03.310.97.30.0 Ø 120/157x2.5
430	Roller bearing	02.6410.29.00	33215	02.6410.24.00 33116	02.6410.23.00 33118
431	Dust cover	03.010.04.09.0	Ø 79/129x8.5	03.010.04.15.0 Ø 84/129x8.5	03.010.05.22.0 Ø 94/149x8.5
435	Hub	see page 72		see page 72	see page 72
441	Roller bearing	02.6410.25.00	32310	02.6410.25.00 32310	02.6410.22.00 33213
		Conventional axle stub (see page 60)			
446	Castle nut	03.262.16.10.0	M 42x2/SW65/ H 36	03.262.16.08.0 M 42x2/SW65	03.262.17.12.0 M 52x2/SW80
447	Split pin	02.6201.82.01	8 x 50 / 1234	02.6201.82.01 8 x 50 / 1234	02.6201.84.01 8 x 63 / 1234
		ECO axle stub (see page 60)			
445	Washer	03.320.73.13.0	Ø 43/61x5.8	03.320.73.13.0 Ø 43/61x5.8	03.320.64.01.0 Ø 53/76x5.8
446	Castle nut	03.262.16.15.0	M 42x2/SW65	03.262.16.15.0 M 42x2/SW65	03.262.17.18.0 M 52x2/SW80
447	Split pin	02.6201.82.01	8 x 50 / 1234	02.6201.82.01 8 x 50 / 1234	02.6201.84.01 8 x 63 / 1234
460	Hub cap (normal)	03.212.23.32.0	M 115 x 2 / SW 95 - 8kt. Alloy	03.212.23.09.0 M 115 x 2 / SW 95	03.212.24.07.0 M 125 x 2 / SW 110
	Hub cap (chrome) ¹⁾	-		03.212.23.21.0 M 115 x 2 / SW 95	03.212.24.23.0 M 125 x 2 / SW 110

¹⁾ Not corrosion-resistant acc. to DIN 50021

H

K

5 Hubs, hub bearings

5.1 Hub bearings

5.1.1 Conventional hub bearing system

H.. / K..

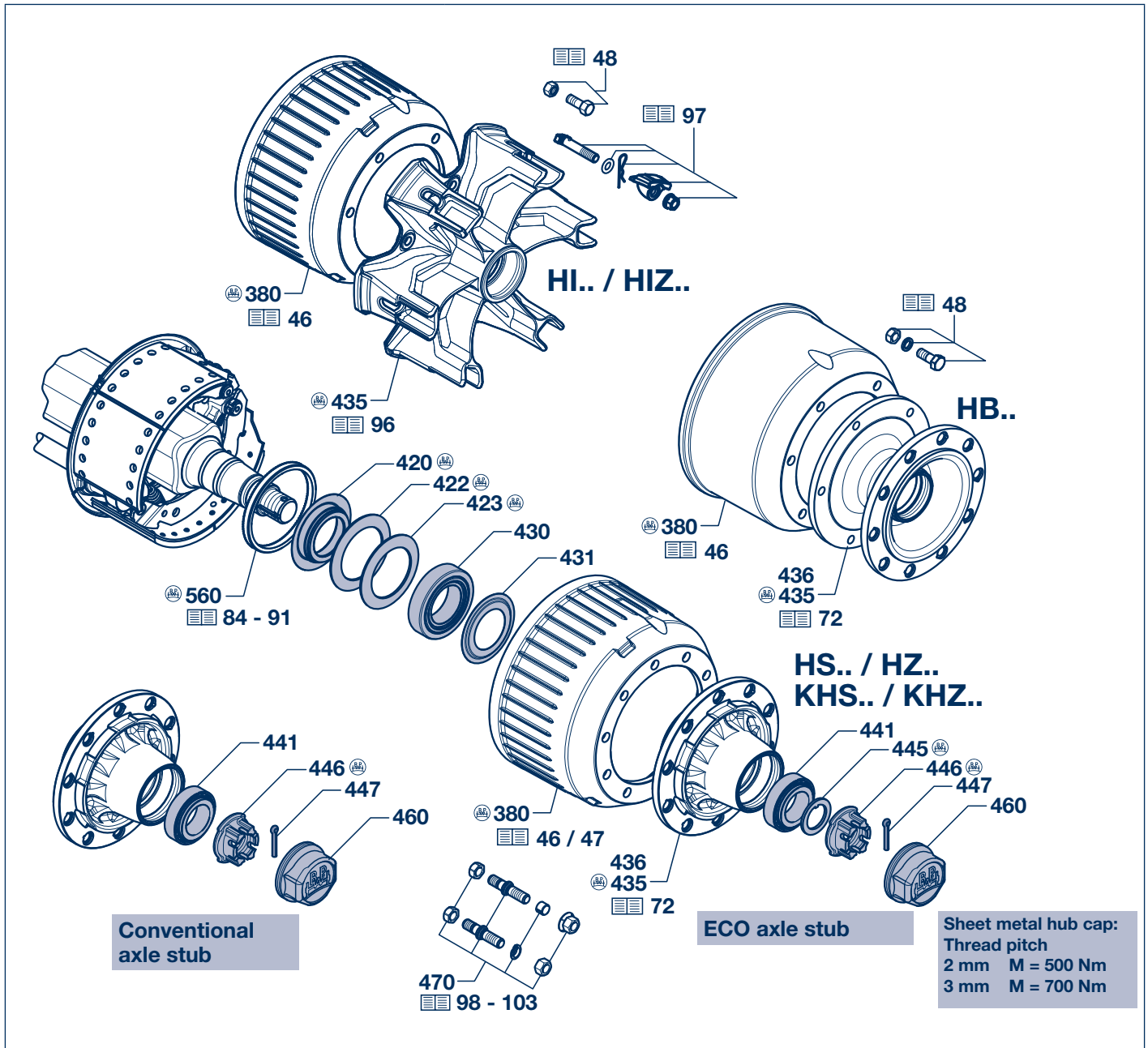

Grease filling, grease quantity and bearing adjustment see page 77

Hub caps with integrated Hubodometer see page 104 - 106

Uniform axle stubs for all BPW trailer axles

As of January 1995 BPW axle beams and steering pivots will be converted to ECO axle stubs. These differ from the conventional axle stubs by a keyway in the thread area.

A new axle nut (item 446) and in addition a washer (item 445) is used to fit the conventional bearing to ECO axle stubs.

Where spare axle beams and steering pivot assemblies are supplied, these are fitted throughout with these new axle nuts and washers.

If the ECO hub system is fitted, these parts are dispensed with.

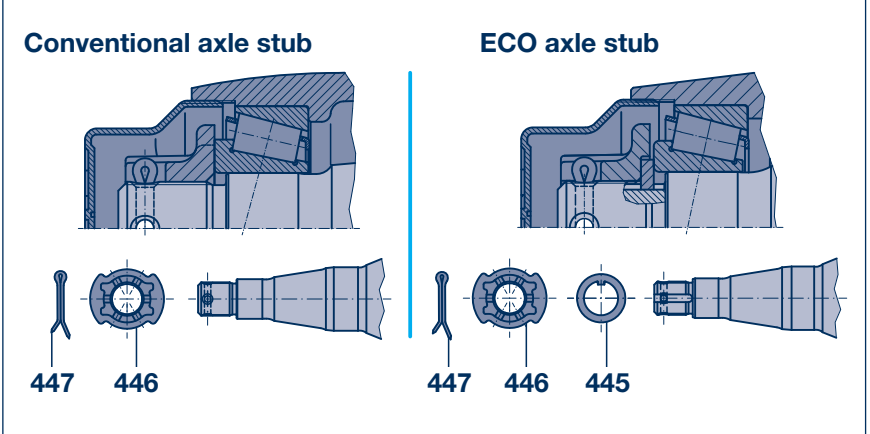

Hubs, hub bearings 5

Hub bearings 5.1

Conventional hub bearing system 5.1.1

H.. / K..

Item	Designation	BPW Code no.	Dimension
		H.. / K.. 13 - 14t (14000-1) --.14.---.---	H.. 16 - 18t --.16.---.---
380	Brake drum	see page 46 / 47	see page 46 / 47
418	Repair kit roller bearing, with thrust washer and hub cap (item 420 - 431, 441, 447, 460)	09.801.07.12.0 for 1 axle side	-
420	Thrust washer	05.370.07.20.0	05.370.07.04.0
422	Ring (Nylon)	03.310.38.21.0 Ø 130/186x4	03.310.99.01.0 Ø 149/212x3.5
423	Ring (Nylon)	03.310.38.20.0 Ø 124/181x4	03.310.99.02.0 Ø 144/205x3.5
430	Roller bearing	02.6410.28.00 32219	02.6410.26.00 32222
431	Dust cover	03.010.05.21.0 Ø 99/169x8.5	03.010.06.12.0 Ø 114/199x8.5
435	Hub	see page 72	see page 72
441	Roller bearing	02.6410.29.00 33215	02.6410.27.00 32314
		Conventional axle stub (see page 62)	
446	Castle nut	03.262.17.11.0 M 60x2/SW85	03.262.17.11.0 M 60x2/SW85
447	Split pin	02.6202.03.01 10 x 71/1234	02.6202.03.01 10 x 71/1234
		ECO axle stub (see page 62)	
445	Ring	03.310.75.12.0 Ø 61/88x5.8	-
446	Castle nut	03.262.17.19.0 M 60x2/SW85	-
447	Split pin	02.6202.03.01 10 x 71/1234	-
460	Hub cap (outer thread)	03.212.25.02.0 M 135 x 3 / SW 120	03.212.26.01.0 M 155 x 3 / SW 120
	Hub cap (inner thread)	03.212.26.20.0 M 150 x 2 / SW 120	-

Only 14 t hubs and hub caps with M 135 x 3 hub cap thread are replaced by hubs and hub caps with M 150 x 2 thread.
Note the modified components.

until 11/2004

Hub with Inner thread M 135 x 3
Hub cap with outer thread M 135 x 3

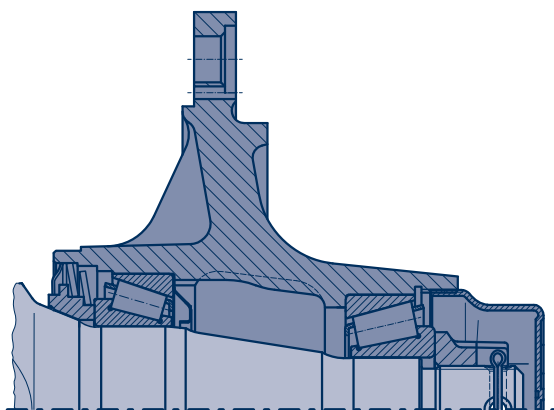

up to 11/2004

Hub with outer thread M 150 x 2
Hub cap with inner thread M 150 x 2

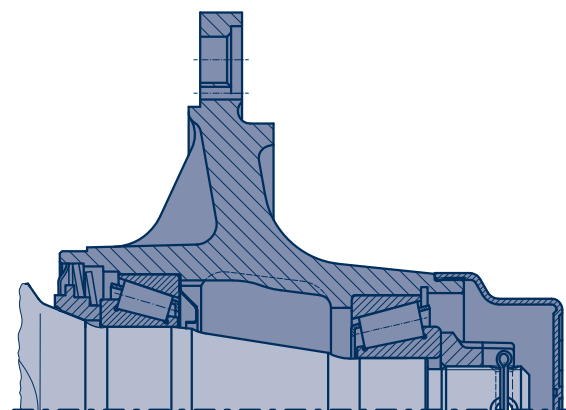

5 Hubs, hub bearings

5.1 Hub bearings

5.1.1 Conventional hub bearing system

N..

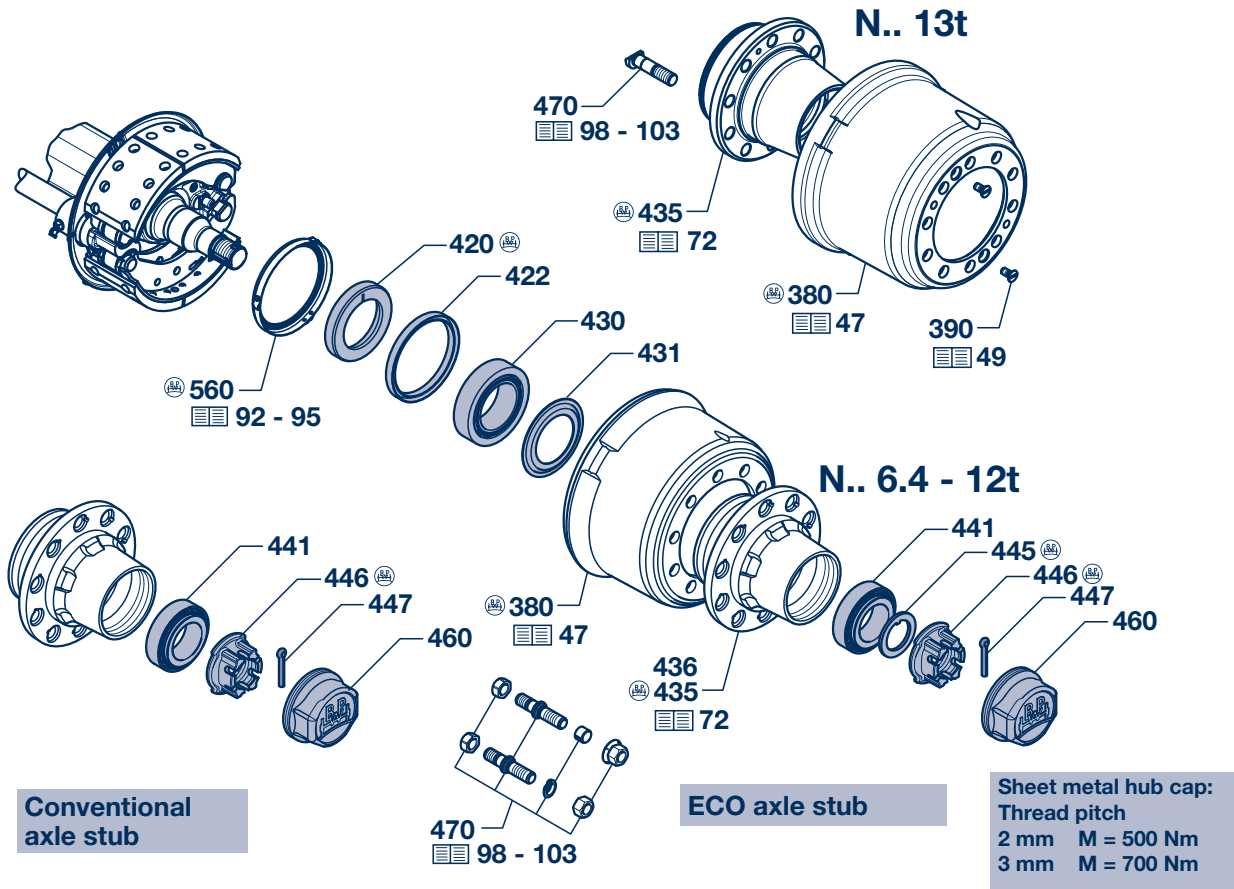

Grease filling, grease quantity and bearing adjustment see page 77

Hub caps with integrated Hubodometer see page 104 - 106

Uniform axle stubs for all BPW trailer axles

As of January 1995 BPW axle beams and steering pivots will be converted to ECO axle stubs. These differ from the conventional axle stubs by a keyway in the thread area.

A new axle nut (item 446) and in addition a washer (item 445) is used to fit the conventional bearing to ECO axle stubs.

Where spare axle beams and steering pivot assemblies are supplied, these are fitted throughout with these new axle nuts and washers.

If the ECO hub system is fitted, these parts are dispensed with.

Conventional axle stub

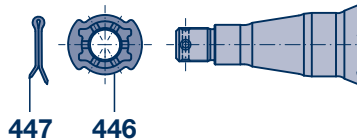
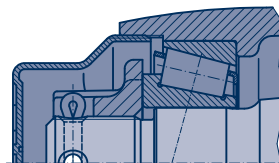

ECO axle stub

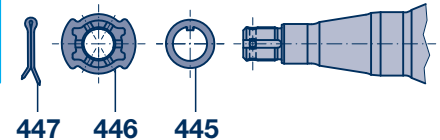
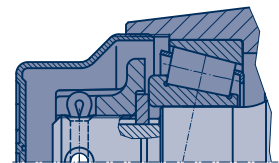

Hubs, hub bearings 5

Hub bearings 5.1

Conventional hub bearing system 5.1.1

N..

Item	Designation	BPW Code no.	Dimension			
		N.. 6.4 - 9t --.06 / 08 / 09.----		N.. 10 - 12t --.10.----		NR.. 13t --.14.----
380	Brake drum	see page 47		see page 47		see page 47
418	Repair kit roller bearing, with thrust washer and hub cap (item 420 - 431, 441, 447, 460)	09.801.02.19.0	for 1 axle side	09.801.02.20.0	for 1 axle side	-
420	Thrust washer	03.370.07.45.0	∅ 86/125x22	03.370.07.44.0	∅ 96/145x22	03.370.08.06.0 ∅ 97/160x32
422	Lip seal	02.5664.26.57	∅ 125/143x13	02.5664.46.57	∅ 145/167x13	02.5664.64.57 ∅ 160/188x14
430	Roller bearing	02.6410.24.00	33116	02.6410.23.00	33118	02.6410.28.00 32219
431	Dust cover	03.010.04.15.0	∅ 84/129x8.5	03.010.05.22.0	∅ 94/149x8.5	03.010.05.21.0 ∅ 99/169x8.5
435	Hub	see page 72		see page 72		see page 72
441	Roller bearing	02.6410.25.00	32310	02.6410.22.00	33213	02.6410.29.00 33215
Conventional axle stub (see page 64)						
446	Castle nut	03.262.16.08.0	M 42x2/SW65	03.262.17.12.0	M 52x2/SW80	03.262.17.11.0 M 60x2/SW85
447	Split pin	02.6201.82.01	8 x 50 / 1234	02.6201.84.01	8 x 63 / 1234	02.6202.03.01 10 x 71/1234
ECO axle stub (see page 64)						
445	Washer	03.320.73.13.0	∅ 43/61x5.8	03.320.64.01.0	∅ 53/76x5.8	-
	Ring	-		-		03.310.75.12.0 ∅ 61/88x5.8
446	Castle nut	03.262.16.15.0	M 42x2/SW65	03.262.17.18.0	M 52x2/SW80	03.262.17.19.0 M 60x2/SW85
447	Split pin	02.6201.82.01	8 x 50 / 1234	02.6201.84.01	8 x 63 / 1234	02.6202.03.01 10 x 71/1234
460	Hub cap (normal)	03.212.23.09.0	M 115 x 2 / SW 95	03.212.24.07.0	M 125 x 2 / SW 110	03.212.25.02.0 M 135 x 3 / SW 120
	Hub cap (chrome) ¹⁾	03.212.23.21.0	M 115 x 2 / SW 95	03.212.24.23.0	M 125 x 2 / SW 110	-

¹⁾ Not corrosion-resistant acc. to DIN 50021

N

5 Hubs, hub bearings

5.1 Hub bearings

5.1.2 ECO / ECO-MAXX hub system (ECO Unit)

H.. / K.. / N..

H
K
N

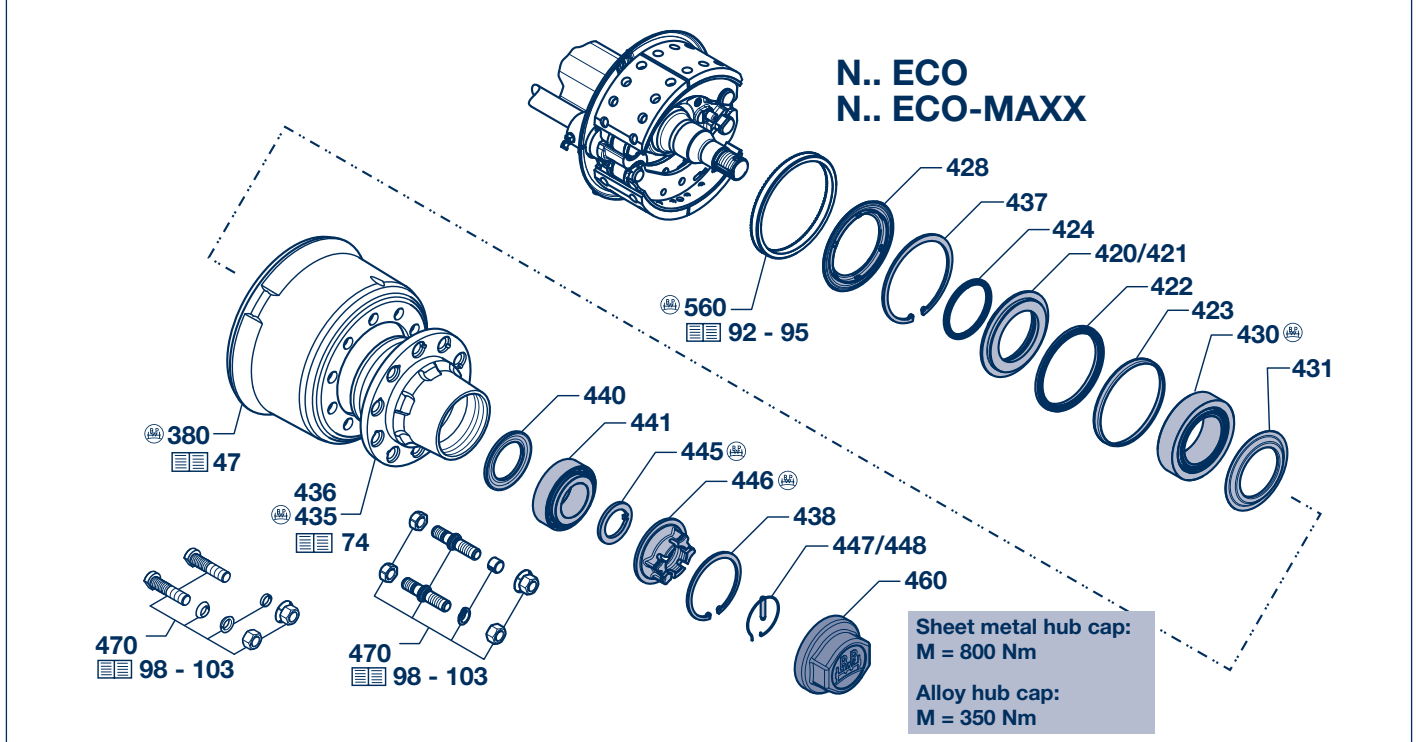
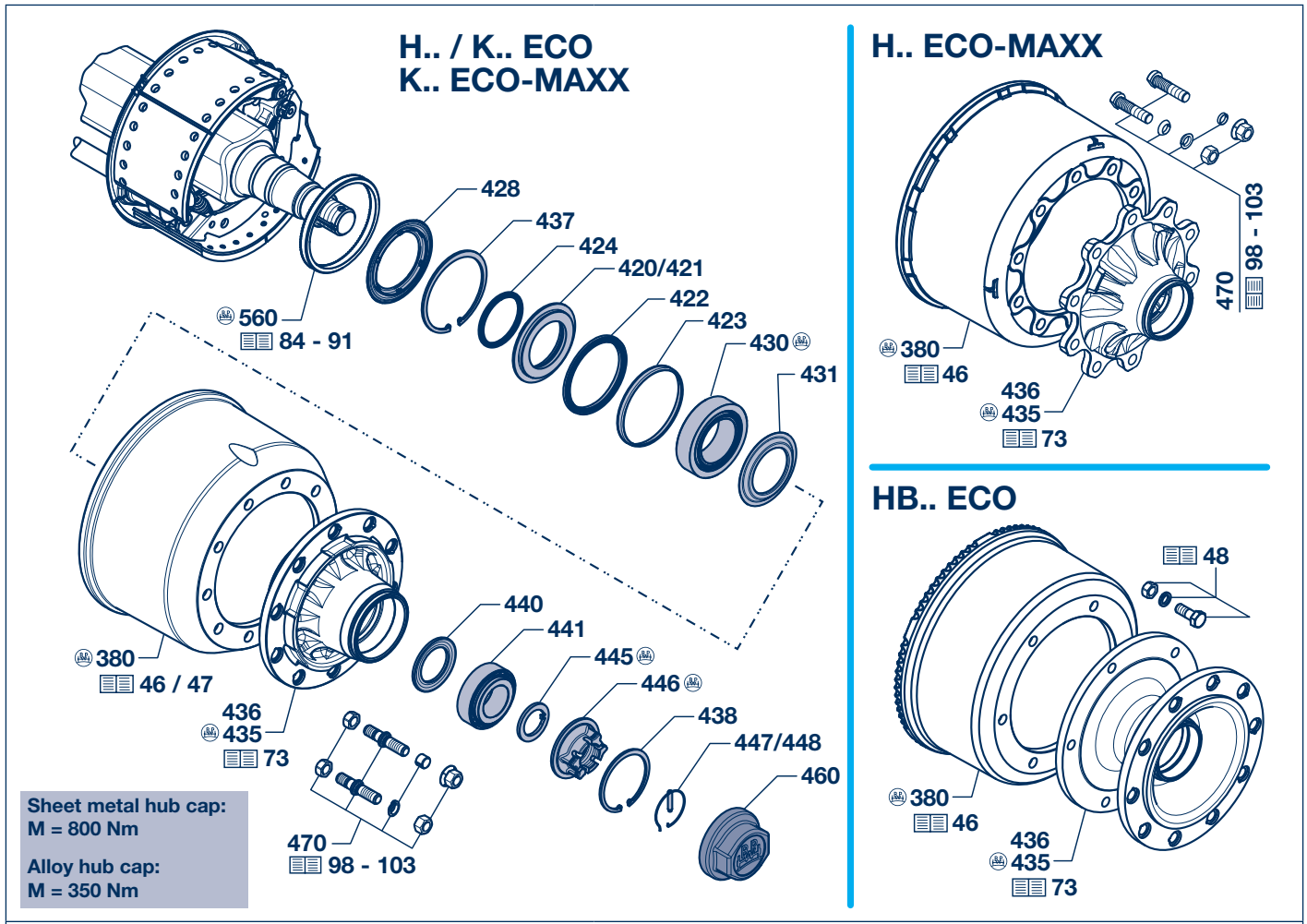

Grease filling, grease quantity and bearing adjustment see page 78

Hub caps with integrated Hubodometer see page 104 - 106

Hubs, hub bearings 5

Hub bearings 5.1

H.. / K.. / N..

ECO- / ECO-MAXX hub system (ECO Unit) 5.1.2

Item	Designation	BPW Code no. Dimension		
		H.. / R.. / K.. / N.. ECO / ECO-MAXX 6.5 - 9t --.36 / 38.---,---	H.. / R.. / K.. / N.. ECO / ECO-MAXX 10 - 12t --.40.---,---	H.. ECO 13t --.44.---,---
380	Brake drum	see page 46 / 47		
418	Repair kit roller bearing, with axle nut and hub cap (item 420, 423, 428 - 431, 437 - 460)	09.801.02.33.0 for 1 axle side	09.801.02.34.0 M 135 x 2 09.801.07.21.0 M 136 x 2.5 for 1 axle side	-
419	Repair kit roller bearing, without axle nut and hub cap (item 420, 423, 430, 431, 441 - 445)	09.801.02.72.0 for 1 axle side	09.801.06.89.0 for 1 axle side	-
420	Thrust washer cpl. (item 421, 422, 424)	05.370.07.67.0	05.370.07.65.0	05.370.08.19.0
421	Thrust washer	03.370.07.60.0 Ø 86 / 115 / 139 x 22	03.370.07.62.0 Ø 96 / 135 / 159 x 22	03.370.08.18.0 Ø 97 / 177 / 179 x 34
422	Lip seal	02.5664.57.00 137-115-10.5	02.5664.58.00 157-135-8	02.5664.59.00 177-155-8
423	Ring	02.5683.62.00 Ø 131/140x12	02.5683.63.00 Ø 151/160x12	02.5683.69.00 Ø 171/179x12
424	'O'-Ring	02.5677.90.40 Ø 90 x 3	02.5678.00.00 Ø 100 x 3	-
428	Dirt seal	02.5681.98.00 Ø 103/147x15	03.120.48.13.0 Ø 133/168x15	-
430	Roller bearing	02.6410.24.00 33116	02.6410.23.00 33118	02.6410.28.00 32219
431	Dust cover	03.010.93.33.0 Ø 84/129x8.5	03.010.93.34.0 Ø 94/149x8.5	03.010.23.03.0 Ø 103/169x8.5
435	Hub	see page 73 / 74		
437	Circlip	02.5606.40.90 140 x 4 / 472	02.5606.60.90 160 x 4 / 472	02.5606.68.90 180 x 4 / 472
438	Circlip	02.5606.12.90 112 x 4 / 472	02.5606.22.90 122 x 4 / 472	02.5606.32.90 132 x 4 / 472
440	Thrust washer	03.370.25.16.0 Ø 54 / 98 x 9	03.370.26.24.0 Ø 71/108x9.5	03.370.26.23.0 Ø 77/120x10
441	Roller bearing	02.6410.25.00 32310	02.6410.22.00 33213	02.6410.29.00 33215
445	Washer	03.320.73.13.0 Ø 43/61x5.8	-	-
	Ring	-	-	03.310.75.12.0 Ø 61/88x5.8
446	Axle nut	03.266.46.02.0 M 42 x 2 / SW65 / Ø 110	03.266.47.03.0 M 52 x 2 / SW80 / Ø 120	03.262.17.17.0 M 60 x 2 / SW85 / Ø 130
447	Bolt	03.084.71.17.0 Ø 8 x 45	03.084.71.17.0 Ø 8 x 45	03.084.72.63.0 Ø 10 x 45
448	Locking ring	03.188.03.06.0 Ø 54 x 2	03.188.04.08.0 Ø 66 x 2	03.188.04.09.0 Ø 76 x 2
460	Hub cap (normal)	03.212.24.25.0 M 125 x 2 / SW 110	03.212.25.08.0* M 135 x 2 / SW 110	03.212.26.14.0 M 150 x 2 / SW 120
		-	03.212.25.33.0* M 136 x 2.5 SW 110	-
	Hub cap (chrome) ¹⁾	03.212.24.26.0 M 125 x 2 / SW 110	03.212.25.23.0* M 135 x 2 / SW 110	-
	Hub cap (Alloy, for alloy hub)	03.212.25.27.0 M 135 x 2 / SW 110	-	-

¹⁾ Not corrosion-resistant acc. to DIN 50021

* **Modified cap thread from 09/00.**
M 135 x 2 was changed to M 136 x 2.5.
Note thread size stamped on the hub cap!

H

K

N

5 Hubs, hub bearings

5.1 Hub bearings

5.1.3 ECO^{Plus} hub system (ECO^{Plus} Unit)

H.. / K..

H
K

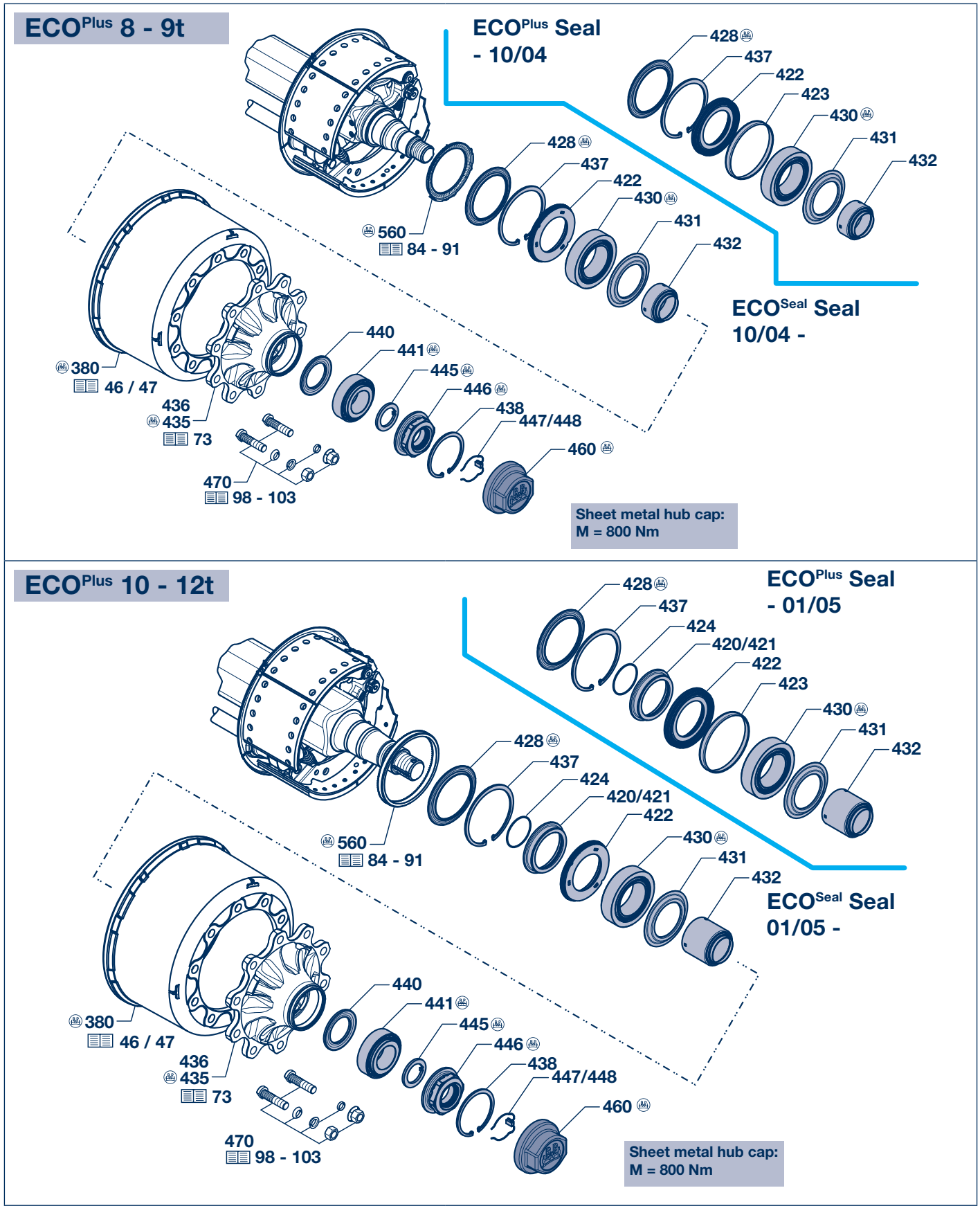

☞ Grease filling, grease quantity and bearing adjustment see page 79

☞ Hub caps with integrated Hubodometer see page 104 - 106

Hubs, hub bearings 5

Hub bearings 5.1

ECO^{Plus} hub system (ECO^{Plus} Unit) 5.1.3

H.. / K..

Item	Designation	BPW Code no.	Dimension
		H.. / KH.. ECO^{Plus} 8 - 9t --.48.---.---	H.. / KH.. ECO^{Plus} 10 - 12t --.50.---.--- --.51.---.---
380	Brake drum	see page 46 / 47	see page 46 / 47
		ECO^{Plus} Seal - 10 / 04	ECO^{Plus} Seal - 01 / 05
419	Repair kit roller bearing, without axle nut and hub cap (item 420, 423, 428, 430, 431, 432, 440 - 445)	-	09.801.06.89.0 for 1 axle side
420	Thrust washer cpl. (item 421, 422, 424)	-	05.370.07.65.0
421	Thrust washer	-	03.370.07.62.0 Ø 96 / 135 / 159 x 22
422	Lip seal	02.5664.68.00	Ø 120 / 157.5 x 20 02.5664.58.00 157-135-8
423	Ring	02.5683.80.00	Ø 151 / 157.6 x 20 02.5683.63.00 Ø 151/160x12
424	'O'-Ring	-	02.5678.00.00 Ø 100 x 3
428	Dirt seal	03.120.48.15.0	Ø 117.5 / 160 x 9.5 03.120.48.13.0 Ø 133/168x15
		ECO^{Seal} Seal 10 / 04 -	ECO^{Seal} Seal 01 / 05 -
419	Repair kit roller bearing, without axle nut and hub cap (item 420, 423, 428, 430, 431, 432, 440 - 445)	09.801.06.26.0	for 1 axle side 09.801.07.04.0 for 1 axle side
420	Thrust washer cpl. (item 421, 424)	-	05.370.07.73.0
421	Thrust washer	-	03.370.07.72.0 Ø 96 / 117.5 / 132 x 22
422	ECO ^{Seal} Seal	02.5664.74.00	Ø 117.5 x 158 x 18.9 02.5664.74.00 Ø 117.5 x 158 x 18.9
424	'O'-Ring	-	02.5678.00.00 Ø 100 x 3
428	Dirt seal ¹⁾	03.120.48.15.0	Ø 117.5 / 160 x 9.5 03.120.48.15.0 Ø 117.5 / 160 x 9.5
430	Roller bearing	02.6410.23.00	33118 02.6410.23.00 33118
431	Dust cover	03.010.93.34.0	Ø 94 / 149 x 8.5 03.010.93.34.0 Ø 94 / 149 x 8.5
432	Seal	03.120.45.15.0	Ø 67 / 95 x 49.5 03.120.45.16.0 Ø 67 / 93 x 90.5
435	Hub	see page 75	see page 75
437	Circlip	02.5606.58.90	158 x 4 / 472 02.5606.60.90 140 x 4 / 472 (- 01 / 05) 02.5606.58.90 158 x 4 / 472 (01 / 05 -)
438	Circlip	02.5606.22.90	122 x 4 / 472 02.5606.22.90 122 x 4 / 472
440	Thrust washer	03.370.26.24.0	Ø 71 / 108 x 8 03.370.26.24.0 Ø 71 / 108 x 8
441	Roller bearing	02.6410.22.00	33213 02.6410.22.00 33213
445	Washer	03.320.64.01.0	Ø 53 / 76 x 5.8 03.320.64.01.0 Ø 53 / 76 x 5.8
446	Axle nut	05.266.47.06.0	M 52 x 2 / SW 95 05.266.47.06.0 M 52 x 2 / SW 95
447	Locking piece	03.277.00.07.0	03.277.00.07.0
448	Locking ring	03.188.04.10.0	03.188.04.10.0
460	Hub cap (normal)	03.212.25.30.0*	M 135 x 2 / SW 110 03.212.25.30.0* M 135 x 2 / SW 110
		03.212.25.31.0*	M 136 x 2.5 / SW 110 03.212.25.31.0* M 136 x 2.5 / SW 110
	Hub cap (chrome) ²⁾	03.212.25.57.0*	M 136 x 2.5 / SW 110 03.212.25.57.0* M 136 x 2.5 / SW 110

¹⁾ Dropped from 7 / 07 with ECO^{Seal}.

²⁾ Not corrosion-resistant acc. to DIN 50021

* Modified hub cap thread from 09/00.
M 135 x 2 was changed to M 136 x 2.5.
Note thread size stamped on the hub cap!

5 Hubs, hub bearings

5.1 Hub bearings

5.1.4 ECO Plus 2 hub system (ECO Plus 2 Unit)

H.. / K.. / N..

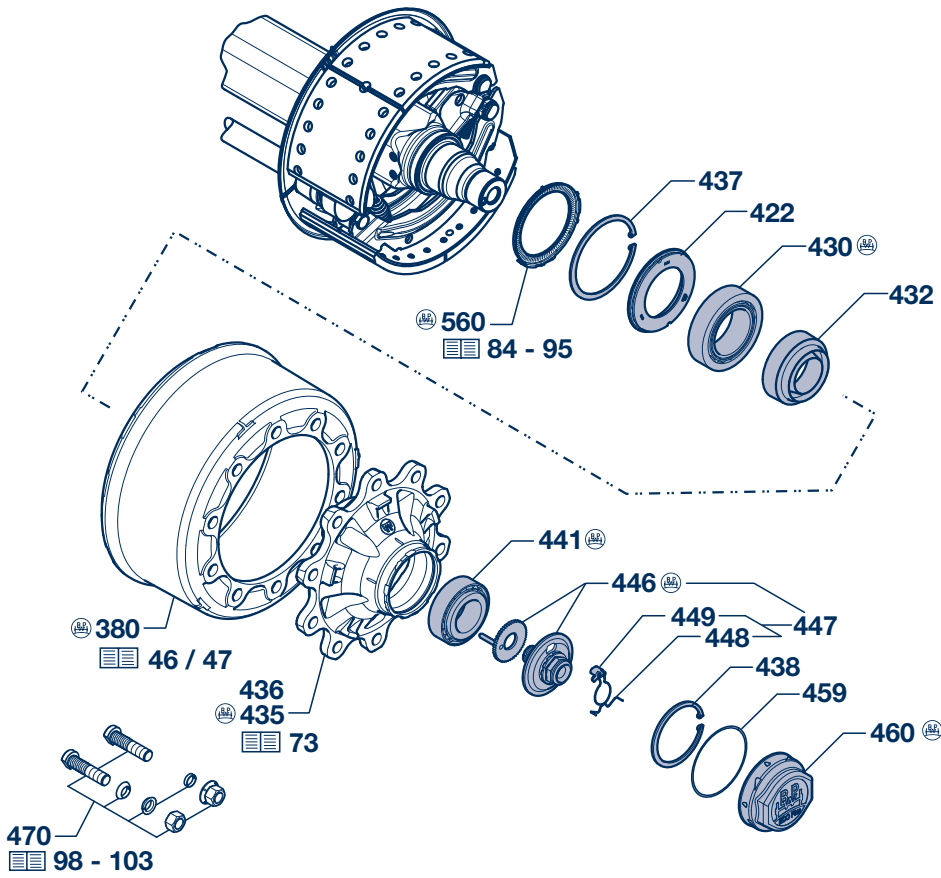

Grease filling, grease quantity and bearing adjustment see page 80

Hub caps with integrated Hubodometer see page 104 - 106

Hubs, hub bearings 5

Hub bearings 5.1

H.. / K.. / N..

ECO Plus 2 hub system (ECO Plus 2 Unit) 5.1.4

Item	Designation	BPW Code no.	Dimension
		H.. ECO Plus 2 KH.. ECO Plus 2 NH.. ECO Plus 2 6.5t --.56.---.--- 8 - 9t --.58.---.--- / --.59.---.---	
380	Brake drum	see page 46 / 47	
418	Repair kit roller bearing, with axle bolt and hub cap (item 422, 430, 432, 437 - 460)	09.801.07.33.0	for 1 axle side
419	Repair kit roller bearing, without axle bolt and hub cap (item 422, 430, 437, 438, 441, 459)	09.801.07.34.0	for 1 axle side
422	ECO ^{Seal} Seal	02.5664.74.00	Ø 117.5 x 158 x 18.9
430	Roller bearing	02.6410.23.00	33118
432	Grease cartridge	03.120.47.08.0	Ø 101 / 130 x 50
435	Hub	see page 76	
437	Circlip	02.5606.58.90	158 x 4 / 472
438	Circlip	02.5606.22.90	122 x 4 / 472
441	Roller bearing	02.6410.22.00	33213
446	Axle bolt with toothed washer (incl. item 447)	09.001.37.03.0	M 32 x 2 / SW 46
447	Locking ring cpl. (item 448 + 449)	05.188.03.10.0	
448	Locking ring	03.188.03.09.0	
449	Locking piece	03.277.10.01.0	
459	'O'-Ring	02.5678.65.00	Ø 128 x 3
460	Hub cap (Bayonet) (incl. item 459)	(normal)	05.212.25.78.0 Ø 137 / 142.6 x 56.3 / SW 120
		(chrome) ¹⁾	05.212.25.81.0 Ø 137 / 142.6 x 56.3 / SW 120

¹⁾ Not corrosion-resistant acc. to DIN 50021

H

K

N

5 Hubs, hub bearings

5.2 Hubs

H.. / K.. / N..

5.2.1 Conventional hub bearing system

Item	Designation (Remark)	BPW Code no.				
SN 42..		H.. / R..				
435	Hub (incl. item 436, page 73)					
		Hub cap thread	6 - 9t --.06/08/09.---.---	10 - 12t --.10.---.---	13 - 14t --.14.---.---	16 - 18t --.14.---.---
280.5 / 335 / 10 x Ø 22 / 6 x Ø 21						
	HB.. Steel and alloy wheels	M 115 x 2	03.275.66.23.0	-	-	-
220.5 / 275 / 8 x Ø 20						
	HS.. / HZ.. Steel wheels	M 115 x 2	03.272.28.52.0	-	-	-
220 / 285 / 8 x Ø 20						
	HZ.. Japanese	M 125 x 2	-	03.272.47.21.0	-	-
220 / 285 / 10 x Ø 20						
	HZ.. Japanese	M 125 x 2	-	03.272.47.20.0	-	-
280.5 / 335 / 10 x Ø 22						
	HS.. Steel and alloy wheels	M 115 x 2	03.272.30.41.0	-	-	-
	HZ.. Steel wheels	M 125 x 2	-	03.272.48.46.0	-	-
	HZ.. Alloy wheels	M 115 x 2	03.272.30.56.0	-	-	-
		M 125 x 2	-	03.272.48.52.0	-	-
	HS.. MAXX	M 135 x 3	-	-	03.272.62.32.0	-
	HZ.. MAXX	M 155 x 3	-	-	-	03.272.80.22.0
	HS.. / HZ.. Steel wheels	M 135 x 3 *	-	-	03.272.62.27.0 *	-
		M 150 x 2	-	-	03.272.62.35.0	-
		M 155 x 3	-	-	-	03.272.80.19.0
* Hub with M 135 x 3 internal thread is changed to hub with M 150 x 2 external thread (see also page 61).						

SN 36..		K..				
435	Hub (incl. item 436, page 73)					
		Hub cap thread	KRBM 6408 --.65.---.---	6.4 - 9t --.06/08.---.---	10 - 12t --.10.---.---	13t --.14.---.---
220.5 / 275 / 8 x Ø 22						
	KRB..	M 115 x 2	03.272.28.35.0	03.272.28.47.0	-	-
		M 115 x 2	-	03.272.28.46.0	-	-
	K..	M 125 x 2	-	-	03.272.46.11.0	-
		M 135 x 3	-	-	-	03.272.60.03.0
175.5 / 225 / 10 x Ø 22						
	K..	M 115 x 2	-	03.272.27.24.0	-	-
		M 125 x 2	-	-	03.272.44.24.0	-
280.5 / 335 / 10 x Ø 22						
	KHS.. 9010/3	M 115 x 2	-	03.272.30.49.0	-	-

SN 30..		N..				
435	Hub (incl. item 436, page 73)					
		Hub cap thread	6 - 9t --.06/08.---.---	10 - 12t --.10.---.---	13t --.14.---.---	
160.5 / 205 / 6 x Ø 20						
	NRS.. / NRZ.. 6006 / 7006	M 115 x 2	03.272.26.07.0	-	-	
160.5 / 205 / 6 x Ø 18 / 2 x M 10						
	NRZ 6006 12" Tyre	M 115 x 2	03.272.26.10.0	-	-	
220.5 / 275 / 8 x Ø 20 / 2 x M 10						
	NRS.. / NRZ..	M 115 x 2	03.272.28.32.0	-	-	
175.5 / 225 / 10 x Ø 22						
	NRS.. / NRZ.. / NHS.. / NHZ..	M 115 x 2	03.272.27.20.0	-	-	
		M 125 x 2	-	03.272.44.30.0	-	
175.5 / 225 / 10 x Ø 22 / 2 x M 12						
	NR.. 13t without ABS	M 135 x 3	-	-	03.272.63.12.0	

Hubs, hub bearings 5

H.. / K..

Hubs 5.2

ECO / ECO-MAXX hub system (ECO Unit) 5.2.2

Item	Designation (Remark)	BPW Code no.				
SN 42..		H.. / R.. ECO / ECO-MAXX				
435	Hub (incl. item 436)					
		Hub cap thread	6.5 - 9t --.36/38.---.---	10 - 12t --.40.---.---	13 - 14t --.44.---.---	Complete hub BPW Code no.
280.5 / 335 / 10 x Ø 22 / 6 x Ø 21						
	HB.. ECO Steel and alloy wheels	M 125 x 2	03.275.66.30.0	-	-	-
220.5 / 275 / 8 x Ø 20						
	HS.. / HZ.. ECO Steel wheels	M 125 x 2	03.272.28.52.0	-	-	-
	HS.. / HZ.. ECO-MAXX	M 125 x 2	03.272.28.70.0	-	-	09.801.06.55.0
220 / 285 / 8 x Ø 20						
	HZ.. ECO Japan	M 136 x 2.5*	-	03.272.47.33.0	-	-
280.5 / 335 / 10 x Ø 22						
	HS.. ECO Steel and alloy wheels	M 125 x 2	03.272.30.87.0	-	-	09.801.06.03.0
	HZ.. ECO Steel wheels	M 136 x 2.5*	-	03.272.43.20.0	-	09.801.06.72.0
		M 150 x 2	-	-	03.272.62.30.0	-
	HS.. ECO-MAXX Steel and alloy wheels	M 125 x 2	03.272.30.97.0	-	-	09.801.06.05.0
	HZ.. ECO-MAXX Steel wheels	M 136 x 2.5*	-	03.272.43.12.0	-	09.801.06.06.0
		M 150 x 2	-	-	03.272.62.33.0	-
	HZ.. ECO Alloy wheels	M 125 x 2	03.272.32.01.0	-	-	-
		M 135 x 2	-	03.272.48.88.0	-	09.801.06.15.0
	HZ.. ECO-MAXX Alloy wheels	M 125 x 2	03.272.30.98.0	-	-	-
		M 136 x 2.5*	-	03.272.43.15.0	-	09.801.06.97.0

SN 36..		K.. ECO / ECO-MAXX			
435	Hub (incl. item 436)				
		Hub cap thread	8 - 9t --.36/38.---.---	10 - 12t --.40.---.---	Complete hub BPW Code no.
220.5 / 275 / 8 x Ø 22					
	K.. ECO	M 125 x 2	03.272.28.56.0	-	09.801.06.51.0
		M 135 x 2	-	03.272.46.15.0	09.801.06.53.0
	KH.. ECO-MAXX	M 125 x 2	03.272.28.70.0	-	09.801.06.55.0
		M 136 x 2.5 *	-	03.272.46.25.0	09.801.06.57.0
	KHZ.. ECO-MAXX Alloy wheels	M 135 x 2	-	03.272.46.19.0	-
175.5 / 225 / 10 x Ø 22					
	K.. ECO	M 125 x 2	03.272.27.41.0	-	09.801.06.50.0
		M 135 x 2	-	03.272.44.34.0	09.801.06.52.0
	K.. ECO-MAXX	M 125 x 2	03.272.27.48.0	-	09.801.06.54.0
		M 136 x 2.5 *	-	03.272.44.40.0	09.801.06.56.0
	KHZ.. ECO Alloy wheels	M 135 x 2	-	03.272.44.35.0	-
280.5 / 335 / 10 x Ø 22					
	KH.. 9010/3 ECO-MAXX	M 125 x 2	03.272.30.91.0	-	09.801.07.23.0
	KH.. 10010/3 ECO / ECO-MAXX	M 136 x 2.5 *	-	03.272.48.90.0	-
280.5 / 335 / 10 x Ø 22 Alloy hub					
	KHSM.. 8010/3 ECO	M 135 x 2	03.272.30.94.0	-	-

Item	Designation (Remark)	Dimension	BPW Code no.	
436	Splined pin	Ø 5 x 19.5	02.6010.25.60	for 6 / 8 holes hub Ø 20
		Ø 6 x 19.5	02.6010.35.60	for 10 holes hub Ø 22

* Modified cap thread from 09/00.
M 135 x 2 was changed to M 136 x 2.5.
Note thread size stamped on the cap!
03.212.25.31.0 = M 136 x 2.5 ECO^{Plus}
03.212.25.33.0 = M 136 x 2.5 ECO / ECO-MAXX

5 Hubs, hub bearings

5.2 Hubs

N..

5.2.2 ECO / ECO-MAXX hub system (ECO Unit)

Item	Designation (Remark)	BPW Code no.		
SN 30..		N.. ECO / ECO-MAXX		
435	Hub (incl. item 436)			
		Hub cap thread	6.4 - 9t ---.36 / 38.---.---	10 - 12t ---.40.---.---
				Complete hub BPW Code no.
	160.5 / 205 / 6 x Ø 20			
	NRS.. / NRZ.. 6006 / 7006 ECO	M 125 x 2	03.272.26.13.0	-
	NHZ.. 6006 ECO	M 125 x 2	03.272.26.14.0	-
	220.5 / 275 / 8 x Ø 20 / 2 x M 10			
	NRS.. / NRZ.. 6008 ECO	M 125 x 2	03.272.28.64.0	-
	NHZ.. 6008 ECO-MAXX (Light weight)	M 125 x 2	03.272.28.70.0	-
				09.801.06.55.0
	175.5 / 225 / 10 x Ø 22			
	N.S.. / N.Z.. ECO	M 125 x 2	03.272.27.41.0	-
	N.S.. / N.Z.. ECO-MAXX (Light weight)	M 125 x 2	03.272.27.48.0	-
				09.801.06.54.0
	N.Z.. ECO	M 125 x 2	03.272.27.44.0	-
	N.Z.. ECO	M 135 x 2	-	03.272.44.34.0
	N.Z.. ECO-MAXX (Light weight)	M 136 x 2.5 *	-	03.272.44.40.0
				09.801.06.52.0
	N.Z.. ECO Alloy wheels	M 135 x 2 *	-	03.272.44.35.0
				-

Item	Designation (Remark)	Dimension	BPW Code no.	
436	Splined pin	Ø 5 x 19.5	02.6010.25.60	for 8 holes hub Ø 20
		Ø 6 x 19.5	02.6010.35.60	for 10 holes hub Ø 22

* Modified cap thread from 09/00.
M 135 x 2 was changed to M 136 x 2.5.
Note thread size stamped on the cap!
03.212.25.33.0 = M 136 x 2.5 ECO-MAXX

Hubs, hub bearings 5

H.. / K..

Hubs 5.2

ECO^{Plus} hub system (ECO^{Plus} Unit) 5.2.3

Item	Designation (Remark)	BPW Code no.		
SN 42..		H.. / R.. ECO^{Plus}		
435	Hub			
		Hub cap thread	8 - 9t --.48.---.---	10 - 12t --.50.---.--- --.51.---.---
	280.5 / 335 / 10 x Ø 22			Complete hub BPW Code no.
	HS.. ECO^{Plus} Steel and alloy wheels	M 135 x 2 *	03.272.32.05.0	-
	HZ.. ECO^{Plus} Steel wheels	M 136 x 2.5 *	03.272.43.10.0 03.272.43.10.2 ¹⁾	09.801.06.07.0
		M 136 x 2.5 *	-	03.272.43.12.0 03.272.43.23.2 ¹⁾
	HZ.. ECO^{Plus} Alloy wheels	M 136 x 2.5 *	-	03.272.43.15.0 03.272.43.25.2 ¹⁾

SN 36..		K.. ECO^{Plus}		
435	Hub			
		Hub cap thread	8 - 9t --.48.---.---	10 - 12t --.50.---.---
	220.5 / 275 / 8 x Ø 22			Complete hub BPW Code no.
	KH.. ECO^{Plus}	M 136 x 2.5 *	03.272.46.28.0 03.272.46.28.2 ¹⁾	09.801.06.69.0
		M 136 x 2.5 *	-	03.272.46.25.0 03.272.46.31.2 ¹⁾
	KHZ.. ECO^{Plus} Alloy wheels	M 136 x 2.5 *	-	03.272.46.26.0 03.272.46.31.2 ¹⁾
	175.5 / 225 / 10 x Ø 22			
	KH.. ECO^{Plus}	M 136 x 2.5 *	-	03.272.44.40.0 03.272.44.43.2 ¹⁾
	280.5 / 335 / 10 x Ø 22			
	KH.. 9010/3 ECO^{Plus}	M 135 x 2 *	03.272.32.05.0	-
		M 136 x 2.5 *	03.272.43.10.0 03.272.43.10.2 ¹⁾	09.801.06.07.0

¹⁾ New ECO^{Plus} hubs with end digit **2** can only be used in conjunction with the new ECO^{Plus} seal (02.5664.74.00).

Further types upon request.

* **Modified cap thread from 09/00.**
M 135 x 2 was changed to M 136 x 2.5.
Note thread size stamped on the cap!
03.212.25.31.0 = M 136 x 2.5 ECO^{Plus}

5 Hubs, hub bearings

5.2 Hubs

H.. / K.. / N..

5.2.4 ECO Plus 2 hub system (ECO Plus 2 Unit)

Item	Designation (Remark)		BPW Code no.		
SN 42..			H.. ECO Plus 2		
435	Hub				
		Hub cap thread	6.5t --56,---,---	8 - 9t --58,---,---	Complete hub BPW Code no.
220.5 / 275 / 8 x Ø 22					
	HS.. ECO Plus 2 Steel wheels	Bayonet lock	03.272.46.33.0	-	09.801.07.36.0
280.5 / 335 / 10 x Ø 22					
	HS.. ECO Plus 2 Steel and alloy wheels HZ.. ECO Plus 2 Steel and alloy wheels	Bayonet lock	03.272.43.29.0		09.801.07.35.0

SN 36..			KH.. ECO Plus 2		
435	Hub				
		Hub cap thread	8 - 9t --58,---,---		Complete hub BPW Code no.
220.5 / 275 / 8 x Ø 22					
	KH.. ECO Plus 2	Bayonet lock	03.272.46.33.0		09.801.07.36.0
280.5 / 335 / 10 x Ø 22					
	KH.. 9010/3 ECO Plus 2	Bayonet lock	03.272.43.29.0		09.801.07.35.0

SN 30..			NH.. ECO Plus 2		
435	Hub				
		Hub cap thread	7 - 9t --56,---,---	8 - 9t --58,---,---	Complete hub BPW Code no.
220.5 / 275 / 8 x Ø 22					
	N.. ECO Plus 2	Bayonet lock	03.272.46.33.0		09.801.07.36.0
175.5 / 225 / 10 x Ø 22					
	N.. ECO Plus 2	Bayonet lock	03.272.44.46.0		09.801.08.03.0

Hubs, hub bearings 5

H.. / K.. / N..

Grease filling per wheel hub, bearing adjustment 5.3

Conventional hub bearing system 5.3.1

Grease filling per wheel hub

Conventional hub bearing system

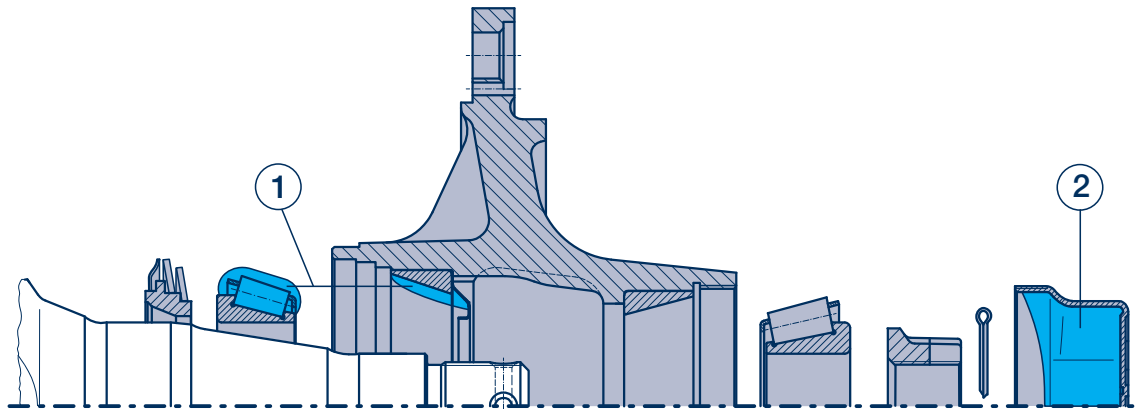

Clean taper roller bearings (using diesel oil) thoroughly, dried, check for serviceability and re-grease.

BPW longlife roller bearing grease ECO-Li 91,
quantity per tapered roller bearing

Axle load	Axle type	① inner		② outer	
		Roller bearing	Quantity	Roller bearing	Quantity
6400kg	KRBM 6408	33215	170 g	32310	290 g
6000 - 9000kg	H.. 6.5 - 9t K.. 6.4 - 9t N.. 6 - 9t	33116	170 g	32310	290 g
10000 - 12000kg	H.. 10 - 12t K.. 10 - 12t N.. 10 - 12t	33118	180 g	33213	320 g
13000 - 14000kg	H.. 13 - 14t K.. 13t N.. 13t	32219	240 g	33215	500 g
16000 - 18000kg	H.. 16 - 18t	32222	400 g	32314	800 g

① Work **BPW longlife roller bearing grease ECO-Li 91** into the spaces between the tapered rollers and the races. Apply remainder to outer race of the hub.

② The bearing grease for the outer tapered roller bearing is pressed into the bearing as the hub cap filled with grease is screwed on.

Bearing adjustment

Conventional hub bearing system

1. Unscrew the hub cap.
2. Remove the axle nut split pin.
3. Tighten the axle nut using a torque wrench to 150 Nm (6 - 14t) or 350 Nm (16 - 20t) while simultaneously turning the wheel hub.
(When using the normal axle nut wrench (tool kit), tighten the axle nut until the wheel hub race is slightly braked).
4. Turn the axle nut back to the next possible pin hole. Should they be in line turn back to the next hole (30° at the maximum).
5. Insert the split pin and bend slightly outwards.
6. Refill the hub cap as required with **BPW longlife roller bearing grease ECO-Li 91**, grease thread of the hub cap all round, screw in and tighten to the prescribed tightening torque.

5 Hubs, hub bearings

5.3 Grease filling per wheel hub, bearing adjustment

H.. / K.. / N..

5.3.2 ECO / ECO-MAXX hub system (ECO Unit)

Grease filling per wheel hub ECO / ECO-MAXX hub system (ECO Unit)

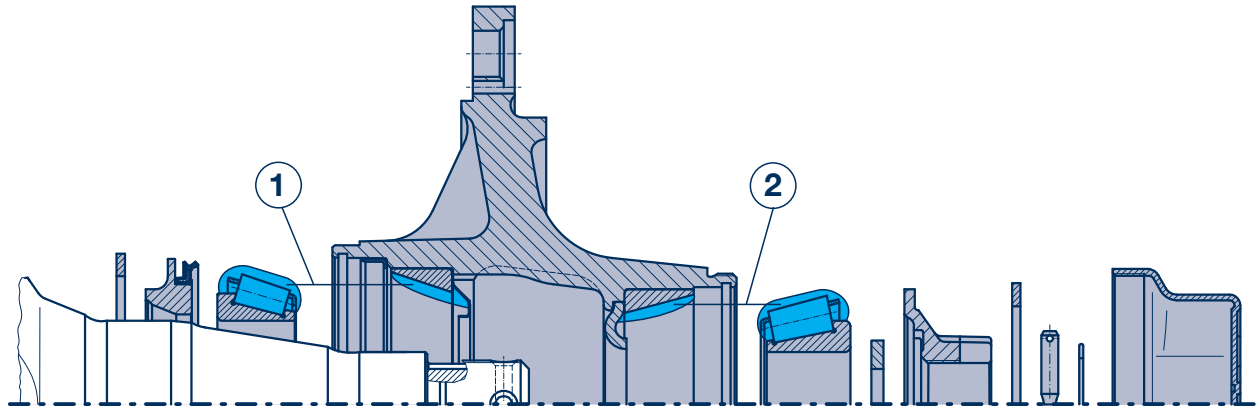

The BPW ECO hub system is designed for longlife lubrication (500,000 km or 3 years under normal conditions). Thereafter clean tapered roller bearings (using diesel oil) thoroughly, dried, check for serviceability and re-grease (observe the current BPW maintenance instructions).

		BPW longlife roller bearing grease ECO-Li 91, quantity per tapered roller bearing			
		① inner		② outer	
Axle load	Axle type	Roller bearing	Quantity	Roller bearing	Quantity
6000 - 9000kg	H.. 6.5 - 9t ECO K.. 6.4 - 9t ECO N.. 6 - 9t ECO	33116	120 g	32310	120 g
10000 - 12000kg	H.. 10 - 12t ECO K.. 10 - 12t ECO N.. 10 - 12t ECO	33118	170 g	33213	120 g
13000 - 14000kg	H.. 13 - 14t	32219	230 g	33215	150 g

① Work **BPW longlife roller bearing grease ECO-Li 91** thoroughly into the spaces between the tapered rollers and the races. Apply remainder to outer races in the hub.
② Renew the lip seal and smear contact area with **BPW longlife roller bearing grease ECO-Li 91**.

Bearing adjustment ECO / ECO-MAXX hub system (ECO Unit)

1. Unscrew the hub cap.
2. Remove the locking bolt with spring ring.
3. By turning wheel hub simultaneously, tighten axle nut with torque wrench to 150 Nm and turn back to the next possible securing hole, max. 15°. - Because of the asymmetric crown of the axle nut the next securing hole will be reached after max. 15°.
4. Re-assemble locking bolt with spring ring.
5. Grease thread of the hub cap around with **BPW longlife roller bearing grease ECO-Li 91**, screw on hub cap and tighten to the prescribed tightening torque (steel hub cap 800 Nm, alloy hub cap 350 Nm).

BPW longlife roller bearing grease ECO-Li 91	Container	BPW Code no.
	0.4 kg Cartridge	02.1040.34.00
	2.5 kg Bucket	02.1040.30.00
	5 kg Bucket	02.1040.31.00
	15 kg Bucket	02.1040.52.00
	50 kg Drum	02.1040.33.00

Hubs, hub bearings 5

H.. / K..

Grease filling per wheel hub, bearing adjustment 5.3

ECO^{Plus} hub system (ECO^{Plus} Unit) 5.3.3

Grease filling per wheel hub

ECO^{Plus} hub system (ECO^{Plus} Unit)

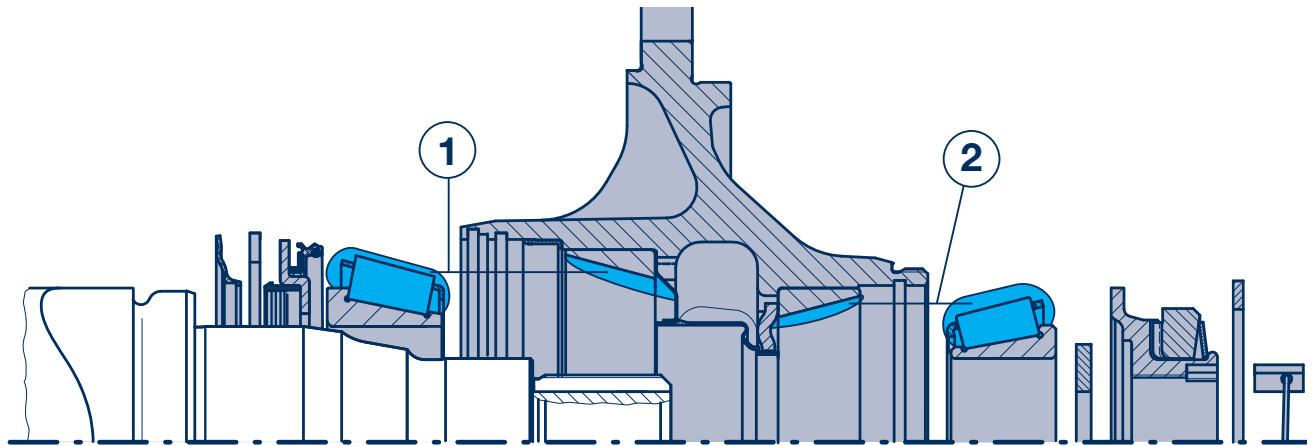

The ECO^{Plus} hub system is designed for the use of longlife grease. On expiry of the guarantee, the roller bearings, the inside of the hub and the seals are to be thoroughly cleaned (with diesel oil), dried, checked to see if they can be re-used; and regreased every three years when used off-road, or every 5 years when used on the road, within Europe (or every year when off-road and every two years when on the road outside of Europe) (observe the current BPW maintenance instructions).

Apply **BPW ECO Protection Grease** (via microflow brush) as thin as possible around the stub-axle bearing seats.

		BPW longlife roller bearing grease ECO-Li ^{Plus} , quantity per tapered roller bearing			
		① inner		② outer	
Axle load	Axle type	Roller bearing	Quantity	Roller bearing	Quantity
8000 - 12000kg	H.. 8 - 12t ECO ^{Plus}	33118	170 g	33213	120 g
	K.. 8 - 12t ECO ^{Plus}		130 g *		90 g *

① Work **BPW longlife roller bearing grease ECO-Li^{Plus}** thoroughly into the spaces between the tapered rollers and the races. Apply remainder to outer races in the hub.
 +
 ② Renew the lip seal and smear contact area with **BPW longlife roller bearing grease ECO-Li^{Plus}**.

* Greasing with grease spray (see page 81)

Bearing adjustment

ECO^{Plus} hub system (ECO^{Plus} Unit)

1. Unscrew the hub cap.
2. Remove the hooked spring ring with a wedge from the axle nut.
3. Use a spanner to tighten the axle nut whilst at the same time turning the wheel hub, until the axle nut torque limiter operates (do not use an impact driver).
4. Fit the retaining key in the groove between the axle stub and the nut (do not reset the axle nut).
5. Insert the hooked spring ring, depending on the version, behind the flange on the axle nut or in the thread on the axle stub.
6. Screw on hub cap and tighten to 800 Nm.

BPW longlife roller bearing grease ECO-Li ^{Plus}	Container	BPW Code no.
	0.4 kg Cartridge	02.1040.45.00
	5 kg Bucket	02.1040.47.00
	25 kg Bucket	02.1040.49.00
	50 kg Drum	02.1040.50.00

5 Hubs, hub bearings

5.3 Grease filling per wheel hub, bearing adjustment

H.. / K.. / N..

5.3.4 ECO Plus 2 hub system (ECO Plus 2 Unit)

Grease filling per wheel hub		ECO Plus 2 hub system (ECO Plus 2 Unit)			
<p>The ECO Plus 2 hub system is designed for the use of longlife grease. On expiry of the guarantee, the roller bearings, the inside of the hub and the seals are to be thoroughly cleaned (with diesel oil), dried, checked to see if they can be re-used; and regreased every three years when used off-road, or every 5 years when used on the road, within Europe (or every year when off-road and every two years when on the road outside of Europe) (observe the current BPW maintenance instructions). Apply BPW ECO Protection Grease as thin as possible and around the entire area of bearing seats of the axle stub.</p>					
		BPW longlife roller bearing grease ECO-Li^{Plus} , quantity per tapered roller bearing			
		① inner		② outer	
Axle load	Axle type	Roller bearing	Quantity	Roller bearing	Quantity
6500 - 9000kg	H.. 6.5 - 9t ECO Plus 2 K.. 8 - 9t ECO Plus 2 N.. 7 - 9t ECO Plus 2	33118	130 g	33213	90 g
<p>① Clean the grease cartridge and fill it on both sides up to the edge with BPW ECO-Li^{Plus} special long-life grease. + Apply a ring-shaped bead of grease to the running surfaces of the outer bearing races. ② Apply a coat of BPW ECO-Li^{Plus} special long-life grease all around the lip of the seal.</p>					
<p>For other procedures see the current maintenance instructions (BPW-W-ECO Plus 1203...e). When BPW grease applicators are used there is no need to fill the grease cartridge or to apply the bead of grease. Greasing with grease spray (see page 81).</p>					

Bearing adjustment	ECO Plus 2 hub system (ECO Plus 2 Unit)
<ol style="list-style-type: none"> Undo the hub cap by turning it through approx. 30 degrees in an anticlockwise direction (see page 59). When turned further the hub cap lifts clearly away from the ECO unit and can be removed by pulling it away. Remove the hooked spring ring and retaining key from the axle bolt. Tighten the axle bolt while at the same time turning the ECO unit with a 46 mm hexagon spanner until the crown of the axle bolt clicks round. NB! Do not use an impact driver. Insert the retaining key into the recess in the axle bolt and into the crown of the toothed lock washer (do not turn the axle bolt back).. Insert the hooked spring ring into the groove at the end of the hexagon profile of the axle bolt. Insert a new O-ring into the groove in the wheel hub. Apply a thin layer of BPW ECO-Li^{Plus} special longlife grease to the hub cap in the area of the O-ring contact surface and the bayonet fitting. Put the hub cap on (position 1, page 59). Use the 120 mm hub cap spanner to lock the hub cap in place by turning it through approx. 30 degrees in a clockwise direction, while at the same time pressing on the hub cap. It is firmly in place when it reaches position 2 (page 59). NB! Do not use an impact driver - bayonet fitting. 	

Hubs, hub bearings 5

H.. / K.. / N..

Grease filling per wheel hub, bearing adjustment 5.4

Grease sprays

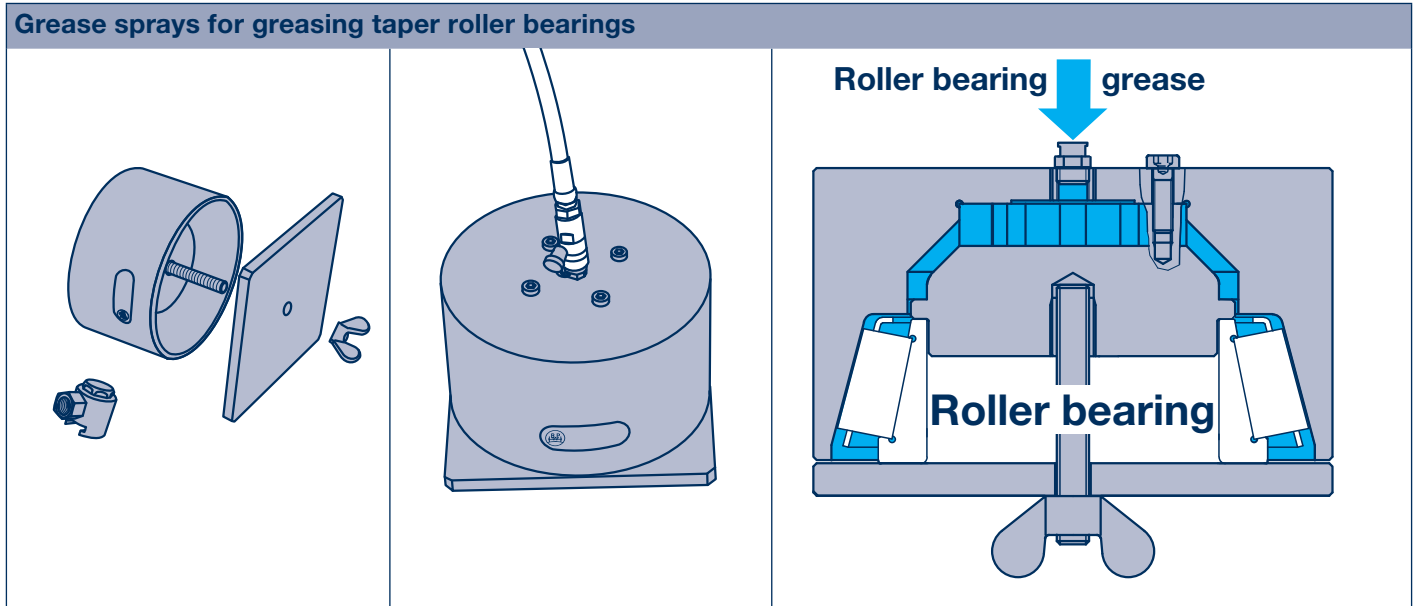

Grease spray	for taper roller bearing	BPW Code no. grease spray loose	BPW Code no. complete set
	33116	16.076.22935	99.00.000.9.54
	32310	16.072.22935	
	33118	16.062.22935	99.00.000.9.55
	33213	16.068.22935	
Complete set including adapter for flat grease nipple			
Adapter for flat grease nipple			BPW Code no.
			15.069.22935

H
K
N

ABS parts 6

General

Pressed-on sheet metal exciter rings

For replacement purposes, pressed-on sheet metal exciter rings are replaced by solid exciter rings.

To do this, heat the new solid exciter ring to approx. 80 to 120 °C and shrink-fit.

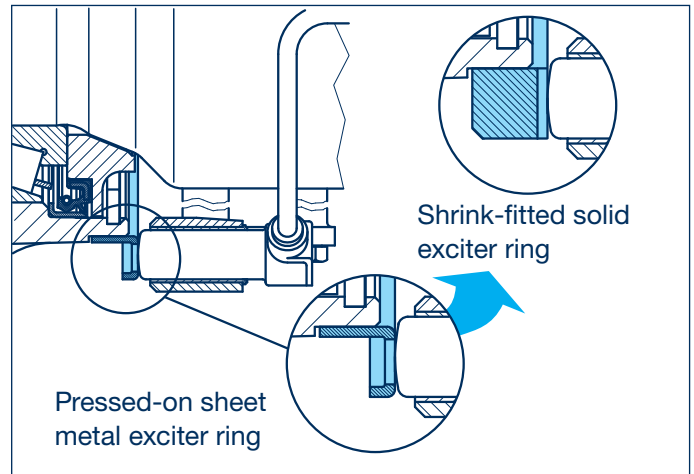

Protected ABS sensor plug connection Since 1997 BPW trailer axles of the H-series are available with the new innovative ABS sensor plug connection. With this design the sensor plug, which sits in a recess in the brake dust covers, is optimally protected against in-transit damage.

The connection of the ABS cables (sensor cable / connection cable to the control unit) is made in the same way as with a normal plug socket by simply inserting the plug into the bracket located in the brake anchor plate.

The firm attachment of the sensor bracket to the brake anchor plate ensures that no damage whatsoever can occur to these ABS components even under the most arduous deployment conditions (assuming that the sensor cable is laid properly).

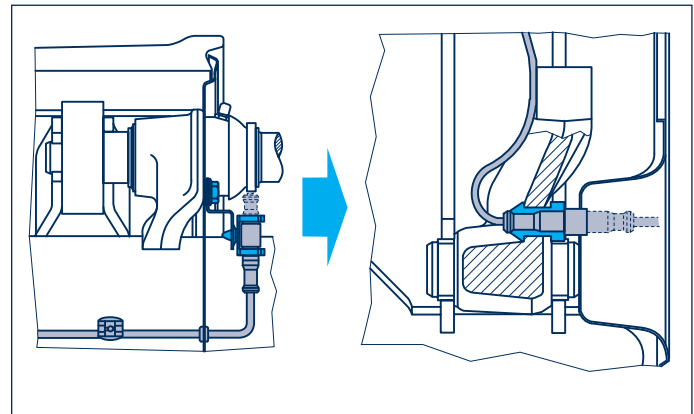

H

K

N

6 ABS

6.1 ABS parts

H.. / R..

SN 42..			H.. / R..
A	B	C	D
E	F	G	H
I	J	K	

Retrofit part sets, see page 90

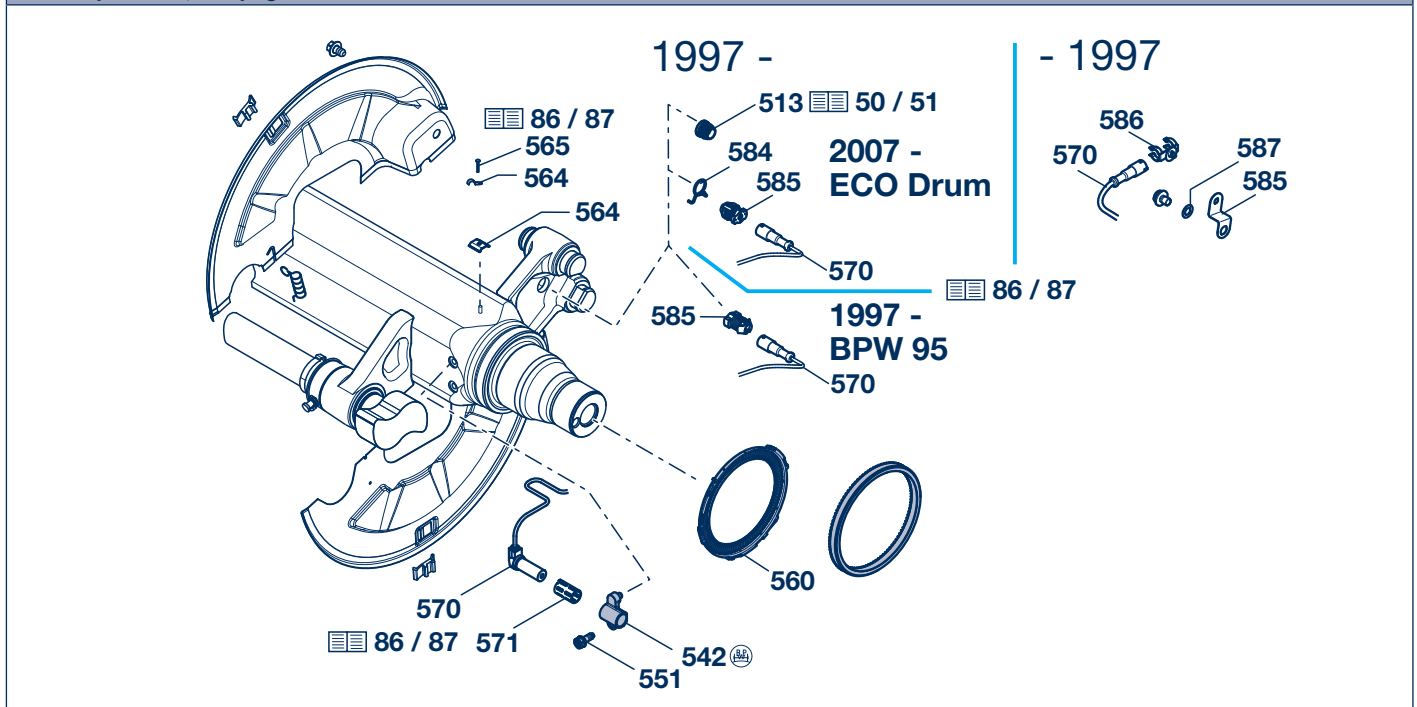

ABS 6

H.. / R..

ABS parts 6.1

SN 42..		H.. / R..		
Item	Designation	BPW Code no.	Dimension	
Sensor bracket for ABS Wabco / Bosch / Grau-Girling DGX / Grau-Girling MGX 100 / Knorr		H.. 6.5 - 9t □ 120 16° Brake position		H.. 10t □ 120 16° Brake position
		H.. 6.5 - 9t □ 120 30° Brake position		H.. ECO^{Plus} 10t □ 120 16° Brake position
		H.. 10 - 14t □ 150		
542	Sensor bracket (right)	03.189.07.10.0	L 25, H 17	Fig. A
		03.189.07.58.0	L 37.5, H 14	Fig. A
543	Sensor bracket (left)	03.189.07.09.0	L 25, H 17	Fig. A
		03.189.07.59.0	L 37.5, H 14	Fig. A
551	Locking bolt	02.5071.23.00	M 8 x 20 (4x)	
		H.. ECO^{Plus} 8 - 9t □ 120		
		H.. ECO Plus 2 8 - 9t □ 120		
542	Sensor bracket	03.189.14.61.0		Fig. B
551	Locking bolt	02.5071.23.00	M 8 x 20 (2x)	
		H.. 9t □ 150		
542	Sensor bracket (right)	05.189.07.18.0		Fig. C
543	Sensor bracket (left)	05.189.07.19.0		Fig. C
		R.. 6.5 - 9t ○ 127	R.. 10 - 12t ○ 127	H.. 16t □ 150
540	Attachment plate	03.080.04.01.0	H 21, α 10°	03.080.03.38.0 H 30, α 5°
542	Sensor bracket			03.189.07.87.0 Fig. D
551	Cylinder cap screw			02.5015.00.80 M 6 x 16 - 8.8 (4x)
553	Spring washer			02.5601.06.90 A 6 / 128 (4x)
		Wabco / Bosch / Grau-Girling DGX / Grau-Girling MGX 100 / Knorr		
560	Ring (Exciter ring)		Fig.	Axle execution
	100 teeth (Z) solid, shrink-fitted, Sheet metal ¹⁾ = 03.310.08.42.0	03.310.08.15.0	Ø 152/170x15	E
				6.5 - 9t □ 120 / ○ 127
	100 teeth (Z) solid, shrink-fitted	03.310.09.31.0	Ø 152/217x15	F
				6.5 - 9t □ 150
	100 teeth (Z) solid, shrink-fitted, Sheet metal ¹⁾ = 03.310.09.35.0	03.310.08.14.0	Ø 176/194x15	G
				10 - 12t □ 120 / 150 / ○ 127
	120 teeth (Z) solid, shrink-fitted	03.310.08.54.0	Ø 176/194x15	G
				10 - 12t ECO^{Plus} □ 120
	100 teeth (Z) solid, shrink-fitted	03.310.08.25.0	Ø 194/216x17.5	H
				13 - 14t □ 150
	100 teeth (Z) solid, shrink-fitted	03.310.09.27.0	Ø 209/218x24	I
				13 - 14t □ 150
	100 teeth (Z) solid, shrink-fitted	03.310.09.36.0	Ø 222/240x15	J
				16t □ 150
	100 teeth (Z) Bayonet	03.310.08.51.0	Ø 125/156x8.5	K
				8 - 9t ECO^{Plus} □ 120 8 - 9t ECO Plus 2 □ 120

¹⁾ For replacement purposes, pressed-on sheet metal exciter rings are replaced by solid exciter rings.

6 ABS

6.1 ABS parts

H.. / R..

SN 42..

H.. / R..

H

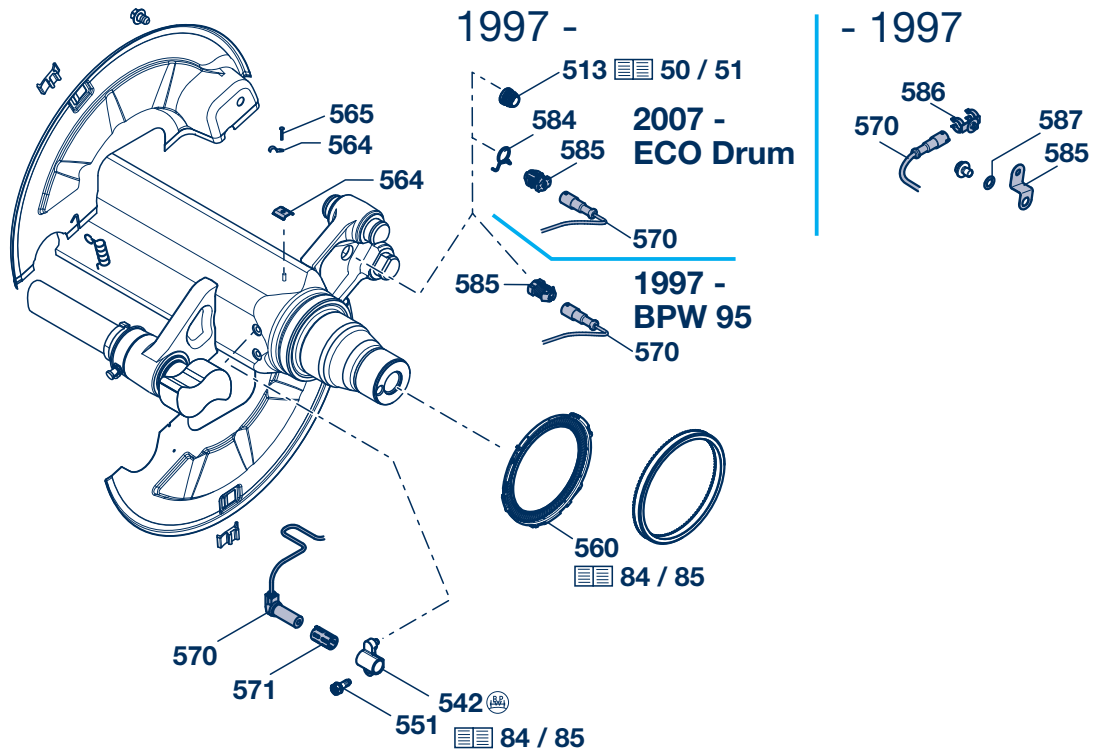

for ABS Wabco / Bosch / Grau-Girling DGX / Grau-Girling MGX100 / Knorr

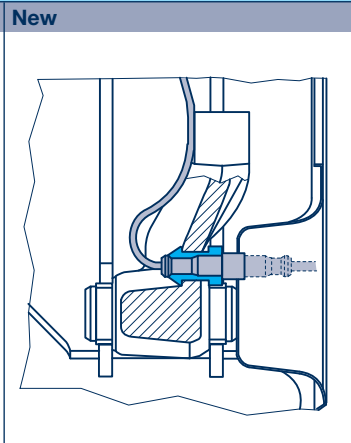
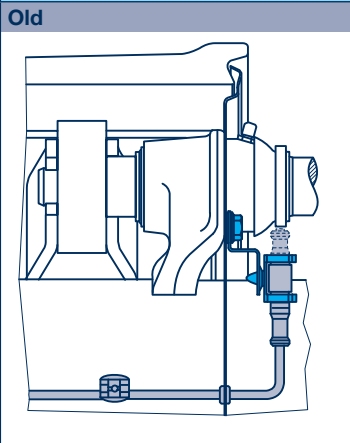

Protected ABS sensor plug connection

Since 1997 BPW trailer axles of the H-series are available with the new innovative ABS sensor plug connection.

With this design the sensor plug, which sits in a recess in the brake dust covers, is optimally protected against in-transit damage.

The connection of the ABS cables (sensor cable / connection cable to the control unit) is made in the same way as with a normal plug socket by simply inserting the plug into the bracket located in the brake anchor plate.

The firm attachment of the sensor bracket to the brake anchor plate ensures that no damage whatsoever can occur to these ABS components even under the most arduous deployment conditions (assuming that the sensor cable is laid properly).

ABS 6**H.. / R..****ABS parts, ABS retrofit part sets 6.1**

SN 42..			H.. / R..
Item	Designation	BPW Code no. Dimension	
		Wabco / Bosch / Grau-Girling DGX / Grau-Girling MGX 100 / Knorr	
564	Clip (for drive pin) Clip (Clip for welded bolt)	02.0326.32.00 1 x 6 / 72571-St 02.3507.32.00	
565	Drive pin	02.6005.25.40 Ø 4 x 10 / 1476-St	
570	Sensor	02.3317.05.00	
571	Bush	02.0316.59.00	
		Old Conventional ABS sensor plug connection, - 1997	New Protected ABS sensor plug connection, 1997 -
584	'O'-Ring Hose clip	- -	02.5679.96.40 Ø 16 x 2.5 BPW 95 03.001.61.01.0 Ø 19 x 2 ECO Drum
585	Support Support (incl. item 584)	03.189.07.35.0 -	03.189.13.90.0 BPW 95 05.189.15.59.0 ECO Drum
586	Support	02.1421.11.00	-
587	Serrated lock washer	02.5414.11.90 A 10.5 / 6798	-

ABS retrofit part sets SN 42..			H.. / R..
ABS retrofit part sets for one axle consisting of exciter rings, sensors, sensor retainers, fastening components and mounting drawings.			for ABS Wabco / Bosch also for Grau-Girling DGX / Grau-Girling MGX 100 / Knorr
Axle type	Remark	Brake	BPW Code no.
H.. 6500 - 9000	<input type="checkbox"/> 120 (up to production week 31/87), Welded sensor bracket	SN 42..-2	05.801.72.17.0
H.. 6500 - 9000	<input type="checkbox"/> 120 (from production week 32/87), Bolted sensor bracket	SN 42..-2 / SN 42.. BPW 95	05.801.72.01.0
H.. 8000 - 9000 ECO^{Plus}	<input type="checkbox"/> 120, Bolted sensor bracket	SN 42.. BPW 95	05.801.74.03.0
H.. 8000 - 9000 ECO Plus 2	<input type="checkbox"/> 120, Bolted sensor bracket	SN 42.. ECO Drum	05.801.74.36.0
H.. ECO^{Plus} 10t 16°.	<input type="checkbox"/> 120, Bolted sensor bracket	SN 42.. ECO Drum	05.801.74.38.0
H.. 10000 - 12000	<input type="checkbox"/> 150 (up to production week 12/88), <input type="checkbox"/> 150 x 16 (up to production week 03/89), Welded sensor bracket	SN 42..-2	05.801.72.19.0
H.. 10000 - 12000	<input type="checkbox"/> 150 (from production week 13/88), <input type="checkbox"/> 150 x 16 (from production week 04/89), Bolted sensor bracket	SN 42..-2 / SN 42.. BPW 95	05.801.72.07.0
H.. 10000 - 12000	<input type="checkbox"/> 150, Bolted sensor bracket	SN 4220 ECO Drum	05.801.74.39.0
H.. 9100 / 10100	<input type="checkbox"/> 150 Brake position 16°, Bolted sensor bracket	SN 42..-2 / SN 42.. BPW 95	05.801.72.59.1
H.. 13000 - 14000	<input type="checkbox"/> 150, Bolted sensor bracket	SN 42..-2 / SN 42.. BPW 95	05.801.73.25.0
H.. 13000 - 14000	<input type="checkbox"/> 150, Bolted sensor bracket	SN 4220 ECO Drum	05.801.73.40.0
H.. 16000 - 18000	<input type="checkbox"/> 150, Bolted sensor bracket	SN 42..-2 / SN 42.. BPW 95	05.801.73.63.0
H.. 16000 - 18000	<input type="checkbox"/> 150, Bolted sensor bracket	SN 4220 ECO Drum	05.801.73.41.0

Further types upon request.

6 ABS

6.1 ABS parts

K..

K

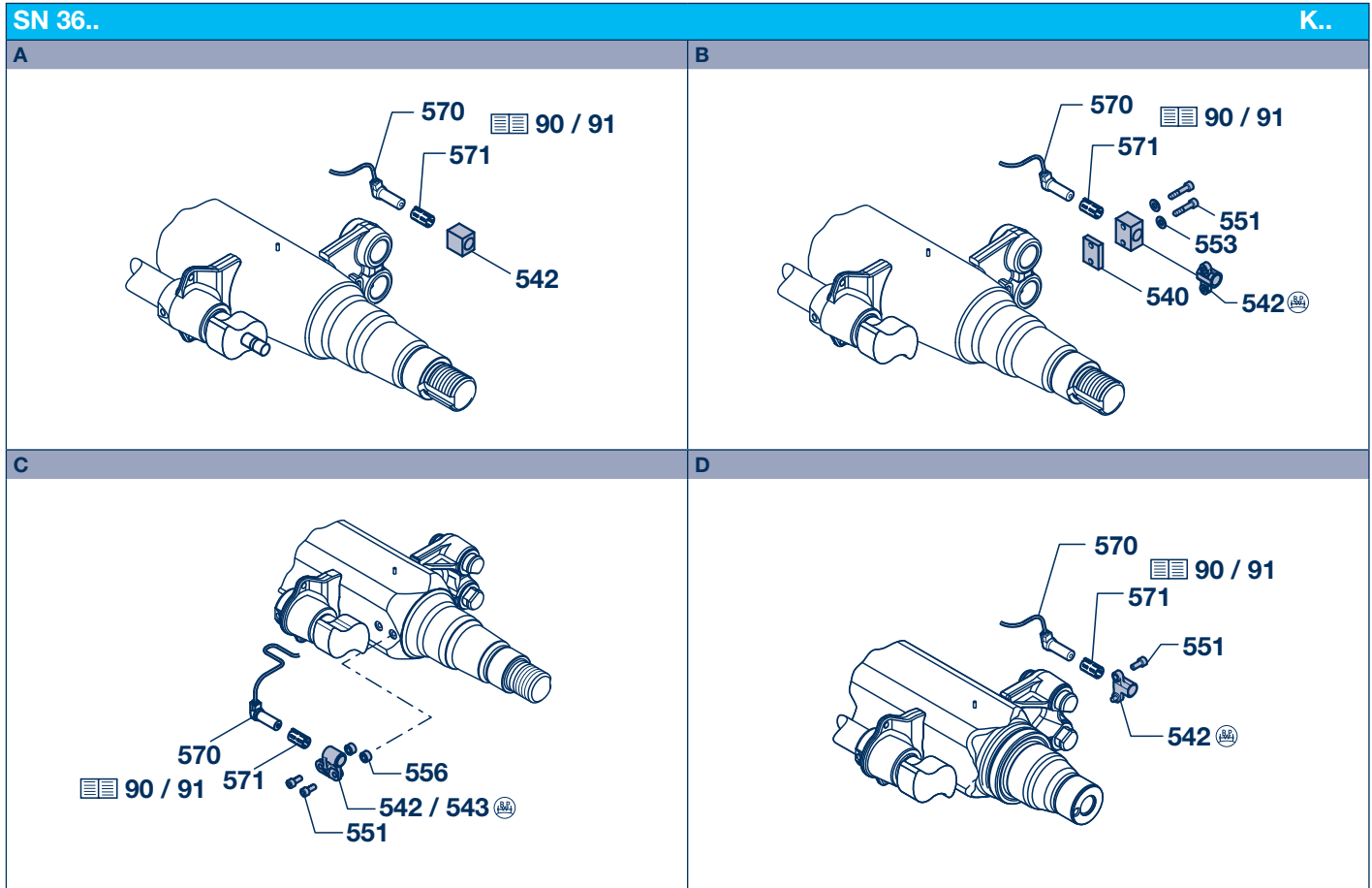

Retrofit part sets, see page 91

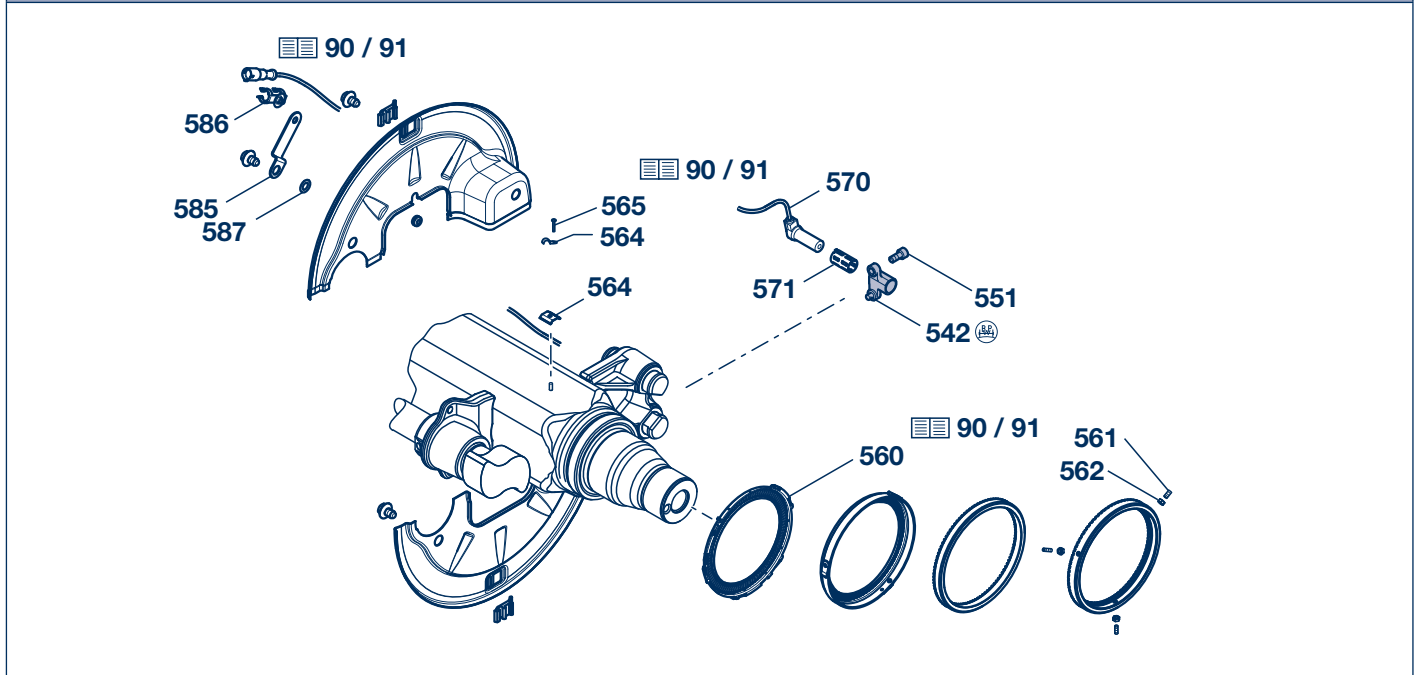

for ABS Wabco / Bosch / Grau-Girling DGX / Grau-Girling MGX100 / Knorr

ABS 6

ABS parts 6.1

K..

SN 36..				K..
Item	Designation (Remark)	BPW Code no.	Dimension	Axle execution
542	Fig. A			
	Block	03.221.56.16.0		KRBM 6408 30.65.542....
	Sensor bracket	05.189.05.19.0		KRB.. 6408 30.06.542....
540	Fig. B			
	Attachment plate	03.080.03.09.0	50 x 20 x 9.5 / 10° / M 6	KR.. 8 - 9t
		03.080.03.05.0	50 x 20 x 15.5 / M 6	KH.. 10t
		03.080.03.03.0	50 x 20 x 16.7 / 5° / M 6	KR.. 10 - 12t
		03.080.03.20.0	U 60 x 5 x 15 x 16 / 6° / M 6	KR.. 10 - 12t
		03.080.04.01.0	U 60 x 5 x 15 / 10° / M 6	KR.. 9t
03.080.03.16.0		60 x 20 x 16 / R65 / M 6	KM.. 13 - 14t	
542	Block	03.221.67.21.0		KR.. 8 - 12t / KH.. 10t
	Sensor bracket	05.189.06.15.0		KM.. 13 - 14t
551	Hexagon bolt	03.189.07.87.0		KR.. 8 - 12t/3 / KR.. 9 - 12t
		02.5021.10.80	M 6 x 35 / 931	KR.. 8 - 12t / KH.. 10t
		02.5015.00.80	M 6 x 16 / 912	KR.. 8 - 12t/3
551	Cylinder cap screw	02.5015.06.80	M 6 x 20 / 912	KM.. 13 - 14t
		02.5601.06.90	A 6 / 127	
542	Fig. C			
	Sensor bracket (right)	03.189.07.58.0		KH.. 8 - 12t
543	Sensor bracket (left)	03.189.07.59.0		KH.. 8 - 12t ECO / ECO-MAXX KH.. 10 - 12t ECO^{Plus}
551	Self-tapping screw	02.5047.14.00	AM 8 x 20 / 7513	KH.. 8 - 9t
	Locking bolt	02.5071.23.00	M 8 x 20	KH.. 10 - 12t ECO^{Plus}
	Self-tapping screw	02.5047.16.00	AM 8 x 30 / 7513	KH.. 10 - 12t
556	Sleeve	03.200.71.06.0	Ø 8.5 / 15 x 20	
542	Fig. D			
	Sensor bracket	03.189.14.61.0		KH.. 8 - 9t ECO^{Plus} /
551	Locking bolt	02.5071.23.00	M 8 x 20 (2x)	KH.. 8 - 9t ECO Plus 2

K

6 ABS

6.1 ABS parts, ABS retrofit part sets

K..

K

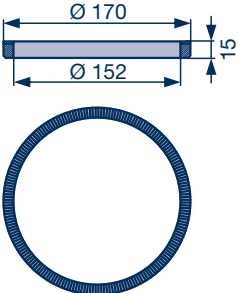
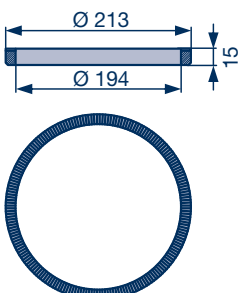
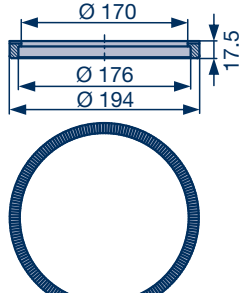
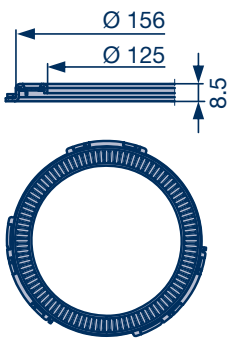
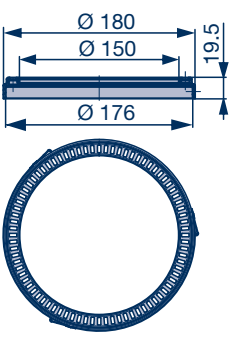
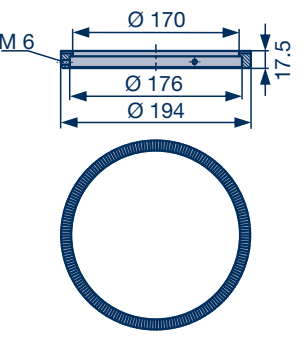
SN 36..			K..		
A 	B 	C 			
D 	E 	F 			

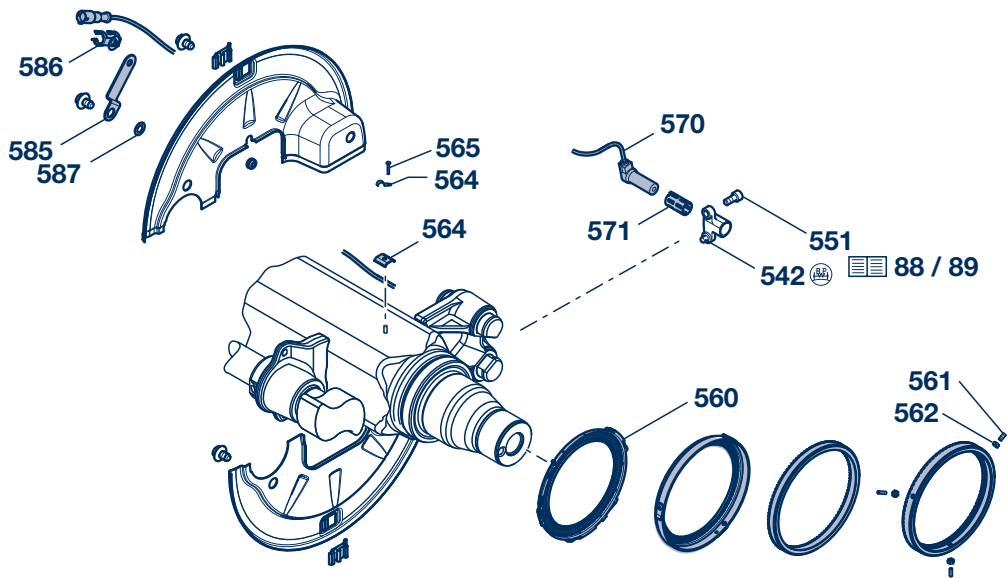

for ABS Wabco / Bosch / Grau-Girling DGX / Grau-Girling MGX100 / Knorr

SN 36..				K..	
Item	Designation (Remark)	BPW Code no.	Dimension	Fig.	Axle execution
560	Ring (Exciter ring)				
	80 teeth (Z) solid, shrink-fitted Sheet metal ¹⁾ = 03.310.08.45.0	03.310.08.18.0	Ø 152/170x15	A	K.. 6.4 - 9t K.. 8 - 12t ECO / ECO-MAXX
	100 teeth (Z) solid, shrink-fitted, Sheet metal ¹⁾ = 03.310.08.42.0	03.310.08.15.0	Ø 152/170x15	A	K.. 8 - 9t/3 K.. 8 - 9t/3 ECO / ECO-MAXX
	80 teeth (Z) solid, shrink-fitted	03.310.08.34.0	Ø 194/213x15	B	KM.. 13 - 14t
	80 teeth (Z) solid, shrink-fitted	03.310.08.26.1	Ø 170/176/194x17.5	C	K.. 10008 - 12008
	80 teeth (Z) Bayonet	03.310.08.53.0	Ø 125/156x8.5	D	K.. 8 - 9t ECO ^{Plus} / K.. 8 - 9t ECO Plus 2
	100 teeth (Z) Bayonet	03.310.08.51.0	Ø 125/156x8.5	D	K.. 8 - 9t/3 ECO ^{Plus} / K.. 8 - 9t/3 ECO Plus 2
	80 teeth (Z) clipped-on	05.310.08.44.1	Ø 150/176/180x19.5	E	K.. 10 - 12t ECO-MAXX K.. 10 - 12t ECO ^{Plus}
	100 teeth (Z) clipped-on	05.310.08.50.1	Ø 150/176/180x19.5	E	K.. 10010/3
	80 teeth (Z) bolted	03.310.08.24.1	Ø 170/176/194x17.5/3xM6	F	K.. 10010 - 12010 K.. 10010 - 12010 ECO
561	Grub screw	02.5018.09.08	M 6x15/914-45H		K.. 10010 - 12010 K.. 10010 - 12010 ECO
562	Hexagon nut	02.5202.10.82	M 6/934		K.. 10010 - 12010 ECO
¹⁾ shrink-fitted sheet metal exciter rings are replaced by solid exciter rings					
564	Clip (for drive pin)	02.0326.32.00	1 x 6 / 72571-St		
	Clip (Clip for welded bolt)	02.3507.32.00			
565	Drive pin	02.6005.25.40	Ø 4 x 10 / 1476-St		
570	Sensor	02.3317.05.00			
571	Bush	02.0316.59.00			
585	Support	03.189.07.72.0			
586	Support	02.1421.11.00			
587	Serrated lock washer	02.5414.11.90	A 10.5 / 6798		

ABS retrofit part sets SN 36..				K..	
ABS retrofit part sets for one axle consisting of exciter rings, sensors, sensor retainers, fastening components and mounting drawings.				for ABS Wabco / Bosch also for Grau-Girling DGX / Grau-Girling MGX 100 / Knorr	
Axle type	Remark	Brake	BPW Code no.		
KH.. 6500 - 9000	□ 120, Bolted sensor bracket	SN 36..	05.801.72.29.0		
KH.. 6500 - 9000	□ 120, Bolted sensor bracket	SN 36.. BPW 95	05.801.72.29.0		
KH.. 8000 - 9000 ECO ^{Plus} / ECO Plus 2	□ 120, Bolted sensor bracket	SN 36.. BPW 95	05.801.74.13.0		
KH.. 8010/3 ECO ^{Plus} / ECO Plus 2	□ 120, Bolted sensor bracket	SN 36.. BPW 95	05.801.74.12.0		
KH.. 10008	□ 120 (from production week 1/89), Bolted sensor bracket	SN 36..	05.801.72.35.0		
KR.. 10008	○ 127	SN 36..	05.801.72.51.0		
KH.. 10010	□ 120 (up to production week 52/88), Welded sensor bracket	SN 36..	05.801.72.33.0		
KH.. 10010	□ 120 (from production week 1/89), Bolted sensor bracket	SN 36..	05.801.72.37.0		
KH.. 10010 - 12010	□ 120, Bolted sensor bracket	SN 36.. BPW 95	05.801.73.67.0		
KR.. 10010	○ 127	SN 36..	05.801.72.43.0		

Further types upon request.

6 ABS

6.1 ABS parts

N..

N

SN 30..		N..
A	B	C
D	E	F

Retrofit part sets, see page 95

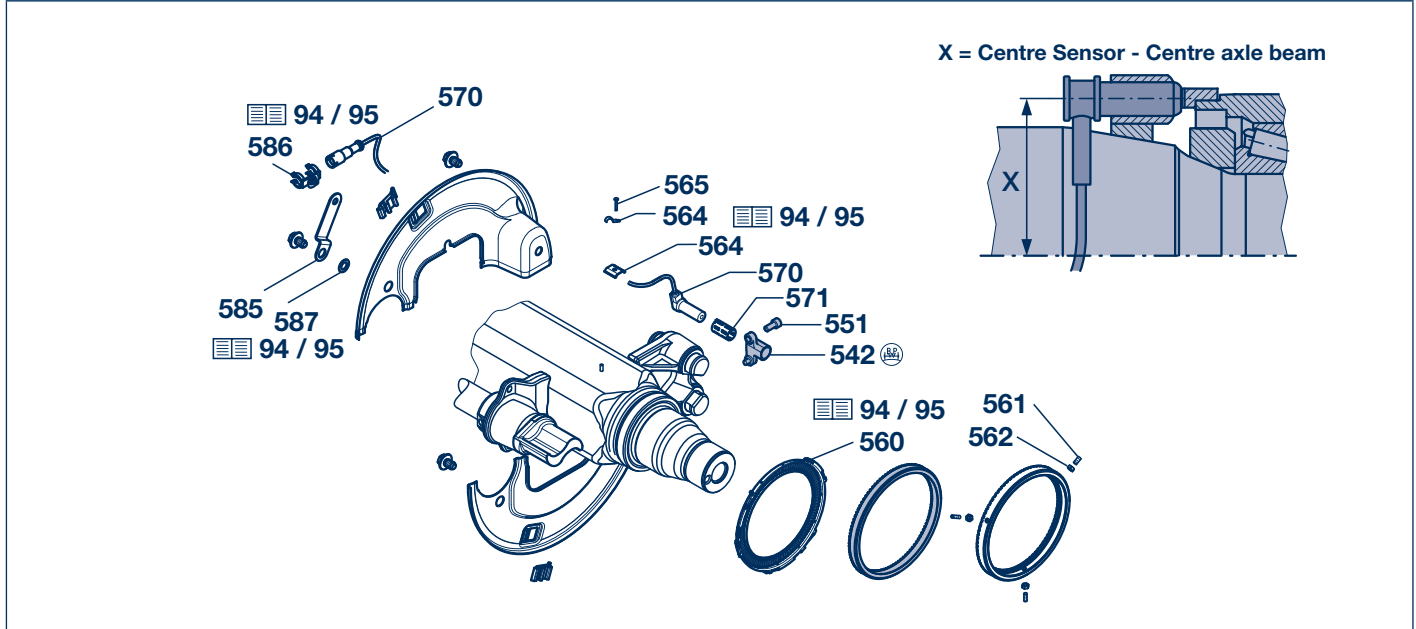

for ABS Wabco / Bosch / Grau-Girling DGX / Grau-Girling MGX100 / Knorr

ABS 6**N..****ABS parts 6.1**

SN 30..						N..			
Item	Designation (Remark)	Year of man.	BPW Code no.	Axle execution / Dimension	X	Suitable for exciter ring			
542	Fig. A	1982 - 1989	05.189.06.23.0	NR.. 6006	77	03.310.08.27.0			
	Support			NR.. 6010 / 6410	81	03.310.08.18.0			
				NR.. 8010 / 9010 TB 295	81	03.310.08.18.0			
540	Fig. B	1985 - 1989	03.080.03.03.0	NR.. 10010 - 12010 TB 295	93	03.310.08.24.1			
542	Attachment plate								
551	Block						03.221.67.21.0		
553	Hexagon bolt						02.5021.10.80	M 6 x 35 / 931	
553	Spring washer	02.5601.06.90	A 6 / 127						
540	Fig. C	1990 - 1995	03.080.03.20.0	NR.. 6006 / 6408 / 6410	77	03.310.08.27.0			
	Attachment plate	1982 - 1989	03.080.04.01.0	NR.. 8010 / 9010 BD 260	81	03.310.08.18.0			
		1990 - 1995	03.080.04.01.0	NR.. 8010 / 9010	81	03.310.08.18.0			
		1982 - 1989	03.080.03.20.0	NR.. 10010 - 12010 BD 260	81	05.310.08.44.1			
		1990 - 1995	03.080.03.20.0	NR.. 10010 - 12010	81	05.310.08.44.1			
542		Support	03.189.07.87.0						
551	Cylinder cap screw	02.5015.00.80	M 6 x 16 / 912						
553	Spring washer	02.5601.06.90	A 6 / 127						
540	Fig. D		03.160.23.01.0	NH.. 6006 / 6408 / 6410	77	03.310.08.43.0			
	Shaped plate								
	542						Support	03.189.12.02.0	
	551						Cylinder cap screw	02.5015.94.80	M 6 x 12 / 912
553	Spring washer	02.5601.06.90	A 6 / 127						
540	Fig. E		03.189.11.77.0	NH.. 8010 / 9010 NH.. 10010 - 12010	81 81	03.310.08.18.0 05.310.08.44.1			
	Support								
	542						Support	03.189.07.87.0	
	550						Self-tapping screw	03.341.00.07.0	M 8 x 20
	551						Cylinder cap screw	02.5015.00.80	M 6 x 16 / 912
	553						Spring washer	02.5601.06.90	A 6 / 127
542	Fig. F		03.189.14.61.0	NH.. 8 - 9t ECO Plus 2	81	03.310.08.53.0			
	Sensor bracket								
551	Locking bolt	02.5071.23.00	M 8 x 20 (2x)						

N

6 ABS

6.1 ABS parts

N..

N

SN 30..			N..
<p>A</p>	<p>B</p>	<p>C</p>	
<p>D</p>	<p>E</p>	<p>F</p>	

X = Centre Sensor - Centre axle beam

92 / 93

for ABS Wabco / Bosch / Grau-Girling DGX / Grau-Girling MGX100 / Knorr

ABS 6**N.. ABS parts, ABS retrofit part sets 6.1**

SN 30..							N..
Item	Designation (Remark)	Year of man.	BPW Code no.	Axle execution / Dimension	X	Fig.	
560	Ring (Exciter ring), utilisation see page 93						
	80 teeth (Z) solid, shrink-fitted		03.310.08.27.0	Ø 145/152/163x17	77	A	
	80 teeth (Z) solid, shrink-fitted		03.310.08.43.0	Ø 148/152/163x17	77	B	
	80 teeth (Z) solid, shrink-fitted		03.310.08.18.0	Ø 152/170x15	81	C	
	80 teeth (Z) clipped-on		05.310.08.44.1 ¹⁾	Ø 150/174/176/180x19.5	81	D	
	80 teeth (Z) Bayonet		03.310.08.53.0	Ø 125/156x8.5	81	E	
	80 teeth (Z) bolted		03.310.08.24.1 ¹⁾	Ø 170/176/194x17.5/3xM6	93	F	
561	Grub screw		02.5018.09.08	M 6x15/914-45H			
562	Hexagon nut		02.5202.10.82	M 6/934			
564	Clip (for drive pin)		02.0326.32.00	1 x 6 / 72571-St	X = see Fig.		
	Clip (Clip for welded bolt)		02.3507.32.00				
565	Drive pin		02.6005.25.40	Ø 4 x 10 / 1476-St			
570	Sensor		02.3317.05.00				
571	Bush		02.0316.59.00				
585	Support		03.189.07.72.0				
586	Support		02.1421.11.00				
587	Serrated lock washer		02.5414.11.90	A 10.5 / 6798			

¹⁾ Exciter rings with mounting bore Ø 176 can also be bolted to hubs with exciter ring seat Ø 175.

ABS retrofit part sets SN 30..				N..
ABS retrofit part sets for one axle consisting of exciter rings, sensors, sensor retainers, fastening components and mounting drawings.			for ABS Wabco / Bosch also for Grau-Girling DGX / Grau-Girling MGX 100 / Knorr	
Axle type	Remark	Brake	BPW Code no.	
NH.. 6000 / 6400	<input type="checkbox"/> 120	SN 3015 BPW 95	05.801.73.51.0	
NR.. 6400	<input type="checkbox"/> 127	SN 30..-1	05.801.72.92.0	
NH.. 7010	<input type="checkbox"/> 120, Bolted sensor bracket	SN 3015 BPW 95	05.801.74.67.0	
NR.. 8008 / 8010	<input type="checkbox"/> 127	SN 30..-1	05.801.72.45.0	
NR.. 8010	<input type="checkbox"/> 127, Brake drums 260 mm wide	SN 30..-1	05.801.72.70.0	
NH.. 8010 / 9010	<input type="checkbox"/> 120, Bolted sensor bracket	SN 3020 BPW 95	05.801.73.53.0	
NH.. 8010 / 9010 ECO Plus 2	<input type="checkbox"/> 120, Bolted sensor bracket	SN 3020 BPW 95	05.801.74.66.0	
NR.. 10010	<input type="checkbox"/> 127, Brake drums 260 mm wide	SN 30..-1	05.801.72.72.0	
NR.. 10010	<input type="checkbox"/> 127	SN 30.. Quick-release brake shoes	05.801.72.98.0	
NH.. 10010 - 12010	<input type="checkbox"/> 120, Bolted sensor bracket	SN 30.. Quick-release brake shoes	05.801.73.55.0	
NH.. 10010 - 12010 ECO MAXX	<input type="checkbox"/> 120, Bolted sensor bracket	SN 3020 BPW 95	05.801.74.83.0	
NR.. 13010	<input type="checkbox"/> 127	SN 30..-1	05.801.72.57.0	

Further types upon request.

7 TRILEX

H..

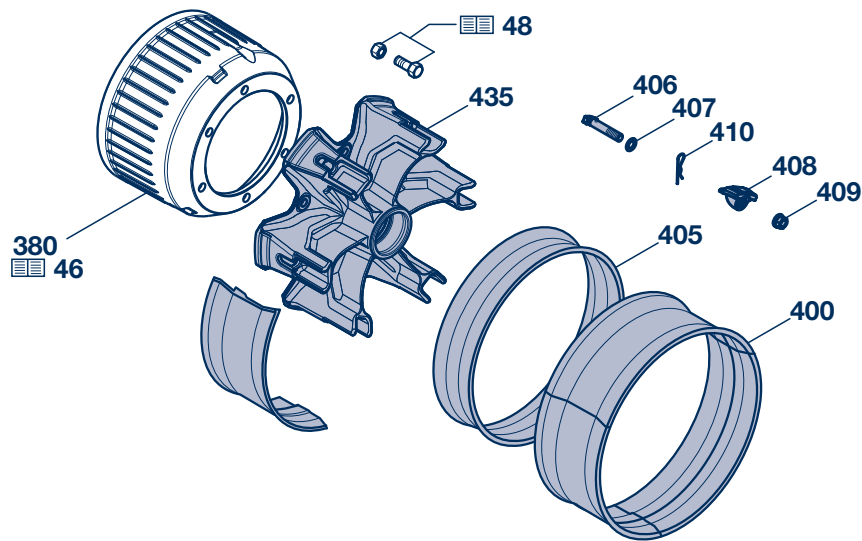

Item	Designation	BPW Code no.	Dimension
		6.5 - 9t -.06. / 08. / 09.----,---	10 - 12t --.10.----,---
435	TRILEX wheel		
	HI.. 20" / 22.5"	02.3910.31.16 ¹⁾ BSI / GF	02.3910.49.38 ³⁾ BSI / GF
	HIZ.. 20" / 22.5"	02.3910.31.24 ²⁾ BSI / GF	03.328.76.48.0 ²⁾ BPW
	HIZ.. 24"	02.3910.31.26 ²⁾ BSI / GF	03.328.76.47.0 ²⁾ BPW
		13 - 14t (14000-1) --.14.----,---	16 - 18t --.16.----,---
	HIZ.. 20" / 22.5"	02.3910.63.02 ¹⁾ BSI / GF	02.3910.82.01 ¹⁾ BSI / GF
	HIZ.. 20" / 22.5"	02.328.83.04.0 ²⁾ BPW	-
	HIZ.. 24"	03.328.83.06.0 ³⁾ BPW	02.3910.82.03 ¹⁾ BSI / GF
	HIZ.. 24"	-	03.328.86.05.0 ²⁾ BPW small spoke

¹⁾ for TRILEX bolts M 18 x 2

²⁾ for TRILEX bolts M 20 x 2

³⁾ for rim 7.5 to 8.5 - 20" and Unilex/Tublex
TRILEX bolts M 20 x 2

H..

Item	Designation	BPW Code no.	Dimension	BSI or GF - No.	
400	Rim	02.1034.06.00	7.0 - 20	650 - 410 - 318	
		02.1034.05.00	7.5 - 20	650 - 410 - 323	
		02.1034.04.00	8.0 - 20	650 - 410 - 327	
		02.1034.02.00	8.5 - 20	650 - 410 - 355	
		02.1034.03.00	10.0 - 20	650 - 410 - 373	
		02.1034.13.00	10.00V - 20	650 - 311 - 235	
		02.1034.29.00	9.00 x 22.5	650 - 511 - 913	
		02.1034.18.00	14.00 x 22.5	650 - 511 - 450	
		02.1034.01.00	8.5 - 24	650 - 410 - 357	
02.1034.07.00	10.0 - 24	650 - 410 - 374			
405	Spacer	02.5671.54.00	124 - 20	656 - 042 - 044	
		02.5671.53.00	130 - 20	656 - 042 - 046	
		02.5671.61.00	139 - 20	656 - 042 - 049	
		02.5671.58.00	177 - 20	656 - 062 - 059	
		02.5671.52.00	130 - 24	656 - 042 - 446	
		02.5671.56.00	139 - 24	656 - 042 - 449	
		02.5671.59.00	147 - 24	656 - 042 - 451	
		02.5671.63.00	177 - 24	656 - 062 - 459	
406	Screw	02.5070.25.00	M 18 x 2 x 95	659 - 112 - 454	
		02.5070.21.00	M 18 x 2 x 110	659 - 112 - 455	
		02.5070.22.00	M 18 x 2 x 125	659 - 112 - 456	
		02.5070.23.00	M 18 x 2 x 140	659 - 112 - 457	
		02.5070.89.00	M 20 x 2 x 57	659 - 112 - 616	
		02.5070.86.00	M 20 x 2 x 100	659 - 112 - 611	
		02.5070.32.00	M 20 x 2 x 115	659 - 112 - 612	
		02.5070.87.00	M 20 x 2 x 130	659 - 112 - 613	
		02.5070.88.00	M 20 x 2 x 145	659 - 112 - 614	
407	Washer	02.5450.22.00	Ø 20.5 / 34 x 2.5	659 - 120 - 228	
408	Clamping plate				
	HIZ..	1	02.1816.14.00	Ø 21 20"/24"	659 - 002 - 171
	HI..	2	02.1816.18.00	Ø 21 20"/24"	659 - 002 - 193
	HI.. Unilex/Tublex E	3	02.1816.19.00	Ø 21 20"/22.5"	659 - 002 - 199
409	Nut	02.5270.03.00	M 18 x 2 / SW 27	659 - 115 - 300	
		02.5270.04.00	M 20 x 2 / SW 27	659 - 115 - 304	
410	Clip	02.1818.10.00		659 - 130 - 017	

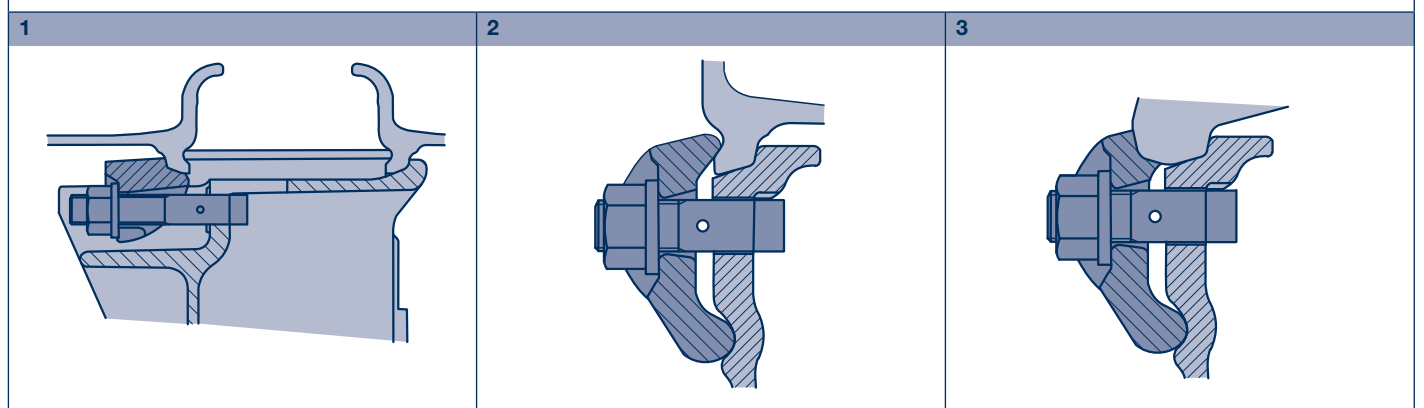

8 Wheel studs

General

BPW Wheel studs

The wheel nave (or wheel disc) connects the rim to the wheel hub. It must absorb the vertical, lateral and longitudinal forces which arise and transmit them to the wheel hub via the wheel studs (wheel bolts).

BPW axles are suitable for wheels with either stud or hub centring. BPW axles are supplied with either collar studs or spiral studs, depending on the axle type and axle load.

Spiral studs are easy to maintain and connect the brake drum to the hub using a pressfit. As a result, there is no need for internal nuts.

The hub bore is not damaged even after several removal/installation operations (in contrast to the situation with splined studs) and the holding forces for the wheel studs remain constant.

A collar stud also allows repeated removal and installation, although it is secured using an internal nut.

The prescribed BPW tightening torques for wheel attachment are listed in the current BPW maintenance instructions and must be observed.

Helical fit wheel bolt (Spiral stud)

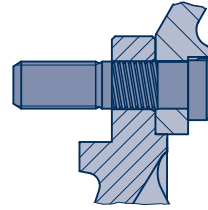

Wheel stud

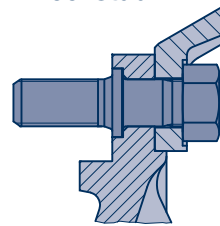

Spherical seat wheel stud

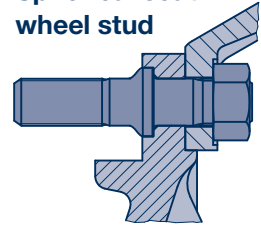

Wheel bolt

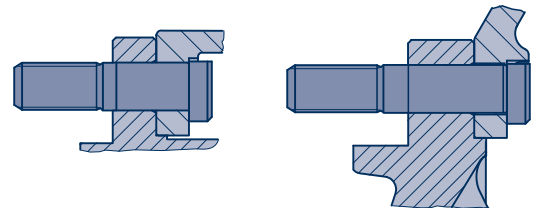

Wheel studs 8

General

Stud alignment

In stud centring, the wheel nave (with countersunk stud holes) is centred using wheel studs with (spring) centring rings.

In the case of spherical studs, the wheel nave is directly centred on the collar of the wheel studs.

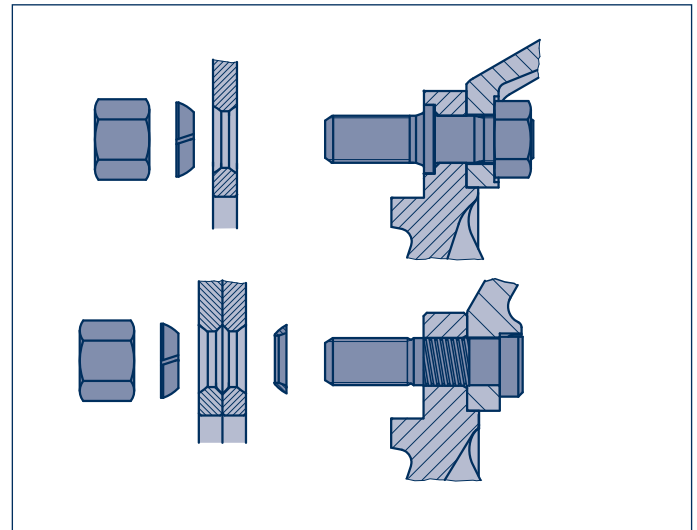

Spigot alignment

In hub centring, the wheel nave is centred using a centring spigot or ring surfaces on the wheel hub.

Centring bushes may be mounted on two opposing wheel bolts of each hub in the case of wheels with hub centring. This is not, however, necessary.

Centring bushes must be mounted on two opposing wheel bolts of each hub in the case of wheels with mixed centring.

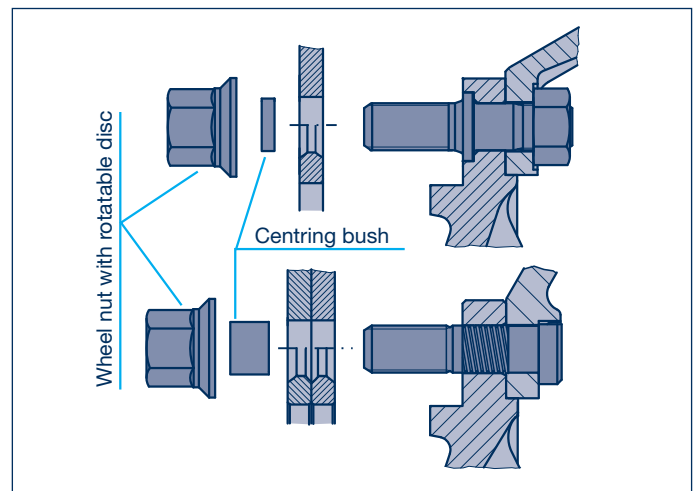

Alloy wheels

In the case of aluminium wheels, the wheel nave is centred using a centring cam or ring surfaces on the wheel hub.

The flange thickness of aluminium wheels

is greater than that of steel wheels, so it is necessary to check whether the vehicle is equipped for having aluminium wheels fitted (with stud hole $\text{Ø} 26$), i.e. whether there is a sufficient hub shoulder and longer wheel studs).

If not, aluminium wheels with stud hole $\text{Ø} 32$ can be used in conjunction with shaft nuts without replacing the hub or the wheel studs.

(The wheel is not centred by the shaft nuts).

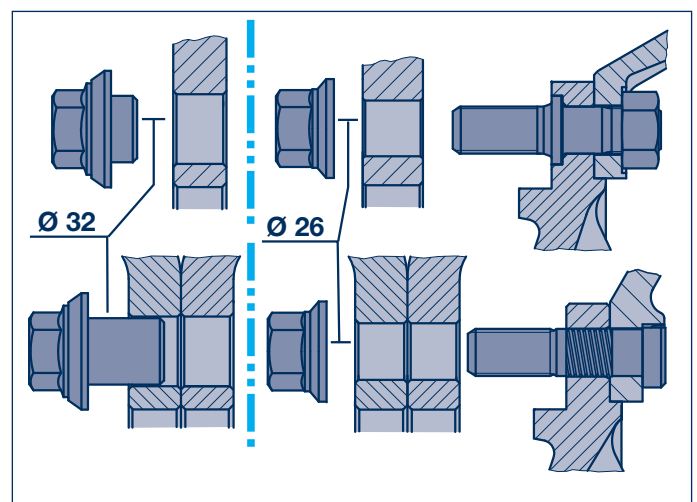

8 Wheel studs

8.1 Single wheels

Thread (D)	Hub		Wheel type						Wheel nut						Fig.	item 470	Dimension Wheel studs L / L1 / L2	item 472	item 474		
	Steel hub	Alloy hub	Steel wheels with offset	Steel wheels without offset	Alloy wheels Ø 26 with offset	Alloy wheels Ø 26 without offset	Alloy wheels Ø 32 with offset	Alloy wheels Ø 32 without offset	Stud alignment	Spigot alignment	normal SW 24	normal SW 27	normal SW 30	normal SW 32						Cap nut SW 33	Shaft nut SW 32
Wheel stud																					
M 18 x 1.5																					
Wheel stud	•		•					•		•							2 A	21.14.0	87 / 36 / 47	21.11.0	03.05.0
	•		•					•		•							~2 B	21.18.0	89 / 41 / 44	21.14.0	03.05.0
M 20 x 1.5																					
Wheel stud	•		•					•		•							2 B	22.05.0	94 / 43 / 47	22.04.0	03.05.0
	•		•					•		•							2 D	22.18.0	94 / 43 / 47	22.04.0	03.05.0
M 22 x 1.5																					
Wheel stud	•		•					•					•				1 A	23.23.0	84 / 46 / 33	23.14.0	04.06.0
	•		•					•					•				1 C	23.17.0	84 / 46 / 33	23.14.0	04.06.0
	•		•					•					•				~1 C	23.36.0	84 / 46 / 33	23.14.0	04.06.0
	•		•					•					•				2 A	23.27.0	100 / 46 / 49	23.15.1	04.06.0
	•		•					•					•				2 C	23.18.0	100 / 46 / 49	23.15.1	04.06.0
	•		•					•					•				~2 C	23.37.0	100 / 46 / 49	23.15.1	04.06.0
	•			•									•				1 E	23.56.0	101 / 60 / 36	23.16.0	04.06.0
	•				•								•				2 E	23.22.0	114 / 60 / 49	23.17.0	04.06.0
	•				•								•				~2 E	23.29.0	114 / 60 / 49	23.17.0	04.06.0
	•					•											1 F	23.52.0	84 / 46 / 33	23.14.0	04.06.0
	•						•										2 F	23.43.0	100 / 46 / 49	23.15.1	04.06.0
Helical fit wheel bolt	•		•					•					•				3 A	33.57.0	89 / 54	33.14.1	-
	•		•					•					•				3 A	33.75.0	80 / 45	33.11.1	-
	•		•					•					•				3 C	33.11.0	89 / 54	33.14.1	-
	•		•					•					•				3 C	33.76.0	80 / 45	33.11.1	-
	•		•					•					•				~3 C	33.61.0	89 / 54	33.14.1	-
	•		•					•					•				~3 C	33.77.0	80 / 45	33.11.1	-
	•			•									•				3 E	33.68.0	97 / 62	33.12.1	-
	•			•									•				~3 E	33.63.0	103 / 58	33.13.1	-
	•				•												3 F	33.64.0	89 / 54	33.14.1	-
	•				•												3 F	33.78.0	80 / 45	33.11.1	-
	•		•					•					•				3 A	33.65.0	103 / 58	33.13.1	-
	•		•					•					•				3 C	33.59.0	103 / 58	33.13.1	-
	•		•					•					•				~3 C	33.66.0	103 / 58	33.13.1	-
	•			•									•				3 E	33.59.0	103 / 58	33.13.1	-
	•			•									•				~3 E	33.66.0	103 / 58	33.13.1	-
	•				•												3 F	33.60.0	103 / 58	33.13.1	-
M 22 x 2																					
Spherical seat wheel stud	•		•					•					•				1 A	23.01.0	84 / 46 / 33	23.02.0	04.06.0
	•		•					•					•				2 A	23.02.0	100 / 46 / 49	23.05.0	04.06.0
	•		•					•									~2 A	23.25.0	100 / 46 / 49	23.05.0	04.06.0

1) Bush not included in wheel stud assembly 09.806..... (page 99).

SW = Spanner width

Wheel studs 8

Single wheels 8.1

item 476	item 478	item 479
Bush *) 03.112.	Spring washer 02.5615.	Wheel nut
-	18.94	02.5213.12.10
-	-	05.260.53.07.0
-	20.90	02.5213.14.10
-	-	02.5219.20.10
-	22.90	03.260.04.12.0
00.43.0	-	05.260.54.10.0
00.43.0	-	05.260.54.19.0
-	22.90	03.260.04.12.0
00.43.0	-	05.260.54.10.0
00.43.0	-	05.260.54.19.0
-	-	05.260.54.10.0
-	-	05.260.54.10.0
-	-	05.260.54.19.0
-	-	05.260.54.21.1
-	-	05.260.54.21.1
-	22.90	03.260.04.12.0
-	22.90	03.260.04.12.0
00.43.0	-	05.260.54.10.0
00.43.0	-	05.260.54.10.0
00.43.0	-	05.260.54.19.0
00.43.0	-	05.260.54.19.0
-	-	05.260.54.10.0
-	-	05.260.54.19.0
-	-	05.260.54.21.1
-	-	05.260.54.21.1
-	22.90	03.260.04.12.0
00.43.0	-	05.260.54.10.0
00.43.0	-	05.260.54.19.0
-	-	05.260.54.10.0
-	-	05.260.54.19.0
-	-	05.260.54.21.1
-	22.90	03.260.04.01.0
-	22.90	03.260.04.01.0
-	22.90	05.260.14.05.0

Wheel stud		Helical fit wheel bolt			
Wheel stud Wheels with offset	1	Wheel stud Wheels without offset	2	Helical fit wheel bolt	3
				<p>Steel hub x = 20 Alloy hub x = 30</p>	
Steel wheels Stud alignment		A	B	Tightening torques for wheel nuts item 479	
				Thread	Stud alignment
				M 18 x 1.5	290 Nm (275-305)
				M 20 x 1.5	380 Nm (360-400)
				M 22 x 1.5	510 Nm (485-535)
				M 22 x 2	460 Nm (435-485)
Steel wheels Spigot alignment		C	D	Tightening torques for wheel nuts item 479	
				Thread	Spigot alignment
				M 18 x 1.5	350 Nm (330-370)
				M 20 x 1.5	480 Nm (455-505)
				M 22 x 1.5	630 Nm (600-660)
Alloy wheels Ø 26		E	F	Tightening torques for wheel nuts item 479	
				Thread	Spigot alignment
				M 22 x 1.5	630 Nm (600-660)
03.260.03.05.0 = M 20 x 1.5 03.260.04.06.0 = M 22 x 2				Tightening torques for rear nuts item 474	
				Thread	
				M 20 x 1.5	300 Nm (270-330)
				M 22 x 2	400 Nm (360-440)

H
K
N

8 Wheel studs

8.2 Twin wheels

	Hub		Wheel type			Wheel nut					Fig.	item 470 Wheel stud assembly cpl. 09.806. (item 472-474, 477-479)	Dimension Wheel studs L / L1 / L2	item 472 Wheel stud 03.296.	item 474 Rear nut 03.260.	item 476 Bush ¹⁾ 03.112.	
	Steel hub	Alloy hub	Steel wheels	Alloy wheels Ø 26	Alloy wheels Ø 32	Stud alignment	Spigot alignment	normal SW 24	normal SW 27	normal SW 32							Cap nut SW 32
Thread (D)																	
Wheel stud																	
M 18 x 1.5																	
Wheel stud	•		•			•		•				1 C	21.19.0	102 / 51 / 47	21.15.0	03.05.0	-
Spherical seat wheel stud	•		•			•		•				2 B	11.11.0	97 / 46 / 47	11.10.0	03.05.0	-
Wheel bolt	•		•			•		•				4 A	31.08.0	81 / 50	31.03.0	-	-
	•		•			•		•				4 D	31.09.0	81 / 50	31.03.0	-	-
M 20 x 1.5																	
Wheel stud	•		•			•		•				1 A	12.03.0	101 / 48 / 47	12.04.0	03.05.0	-
Wheel bolt	•		•			•		•				4 A	32.07.0	89 / 56	32.03.0	-	-
	•		•			•		•				4 D	32.06.0	89 / 56	32.03.0	-	-
M 22 x 1.5																	
Wheel stud	•		•			•		•				1 A	23.28.0	114 / 60 / 49	23.17.0	04.06.0	-
	•		•			•		•				1 C	23.22.0	114 / 60 / 49	23.17.0	04.06.0	00.42.0
	•		•			•		•			•	~1 C	23.29.0	114 / 60 / 49	23.17.0	04.06.0	00.42.0
	•		•			•		•				1 E	23.50.0	139 / 85 / 49	23.24.0	04.06.0	-
	•		•			•		•			•	~1 E	23.49.0	139 / 85 / 49	23.24.0	04.06.0	-
	•		•			•		•			•	1 F	23.44.0	139 / 85 / 49	23.24.0	04.06.0	-
Helical fit wheel bolt	•		•			•		•				3 A	33.67.0	97 / 62	33.12.1	-	-
	•		•			•		•				3 C	33.68.0	97 / 62	33.12.1	-	00.42.0
	•		•			•		•			•	~3 C	33.69.0	97 / 62	33.12.1	-	00.42.0
	•		•			•		•				3 E	-	117 / 82	33.17.1	-	-
	•		•			•		•			•	3 F	-	97 / 62	33.12.1	-	-
Wheel bolt	•		•			•		•				5 A	33.06.0	92 / 70	33.08.0	-	-
	•		•			•		•				5 C	33.07.0	92 / 70	33.08.0	-	00.42.0
	•		•			•		•			•	~5 C	33.09.0	92/70	33.08.0	-	00.42.0
	•		•			•		•				6 A	33.70.0	128 / 84	33.09.0	-	-
	•		•			•		•				6 C	33.71.0	128 / 84	33.09.0	-	00.42.0
	•		•			•		•			•	~6 C	33.72.0	128 / 84	33.09.0	-	00.42.0
	•		•			•		•				6 D	33.73.0	128 / 84	33.09.0	-	-
	•		•			•		•			•	~6 D	33.72.0	128 / 84	33.09.0	-	-
	•		•			•		•			•	6 F	33.74.0	128 / 84	33.09.0	-	-
M 22 x 2																	
Spherical seat wheel stud	•		•			•		•				2 B	13.02.0	111 / 57 / 49	13.09.0	04.06.0	-
	•		•			•		•			•	~2 B	13.09.0	111 / 57 / 49	13.09.0	04.06.0	-
	•		•			•		•			•	~2 B	13.23.0	111 / 57 / 49	13.09.0	04.06.0	-

¹⁾ Bush not included in wheel stud assembly 09.806..... (page 99).

SW = Spanner width

²⁾ Centring ring bei Wheel stud und Twin wheels

Wheel studs 8

Twin wheels 8.2

item 477	item 478	item 479
Centring ring ²⁾ 03.310.	Spring washer 02.5615.	Wheel nut
-	-	05.260.53.07.0
-	18.94	02.5213.12.14
10.27.0	18.94	02.5213.12.14
-	-	05.260.53.07.0
-	20.90	02.5213.14.10
10.02.0	20.90	02.5213.14.10
-	-	02.5219.20.10
10.13.0	22.90	03.260.04.12.0
-	-	05.260.54.10.0
-	-	05.260.54.19.0
-	-	05.260.54.10.0
-	-	05.260.54.19.0
-	-	05.260.54.14.1
10.13.0	22.90	03.260.04.12.0
-	-	05.260.54.10.0
-	-	05.260.54.19.0
-	-	05.260.54.10.0
-	-	05.260.54.19.0
-	-	05.260.54.14.1
10.13.0	22.90	03.260.04.12.0
-	-	05.260.54.10.0
-	-	05.260.54.19.0
-	-	05.260.54.10.0
-	-	05.260.54.19.0
-	-	05.260.54.14.1
-	22.90	03.260.04.01.0
-	22.90	05.260.14.03.0
-	22.90	05.260.14.05.0

Wheel stud	Spherical seat wheel stud	Helical fit wheel bolt	Wheel bolt
1	2	3	
4	5	6	
Steel wheels Stud alignment A	B	Tightening torques for wheel nuts item 479	
		Thread	Stud alignment
		M 18 x 1.5	290 Nm (275-305)
		M 20 x 1.5	380 Nm (360-400)
		M 22 x 1.5	510 Nm (485-535)
		M 22 x 2	460 Nm (435-485)
Steel wheels Spigot alignment C	D	Tightening torques for wheel nuts item 479	
		Thread	Spigot alignment
		M 18 x 1.5	350 Nm (330-370)
		M 20 x 1.5	480 Nm (455-505)
		M 22 x 1.5	630 Nm (600-660)
Alloy wheels Ø 26 E	F	Tightening torques for wheel nuts item 479	
		Thread	Spigot alignment
		M 22 x 1.5	630 Nm (600-660)
03.260.03.05.0 = M 20 x 1.5 03.260.04.06.0 = M 22 x 2		Tightening torques for rear nuts item 474	
		Thread	
		M 20 x 1.5	300 Nm (270-330)
		M 22 x 2	400 Nm (360-440)

H

K

N

9 Accessory

9.1 Hub caps with integrated Hubodometer

Axle load	Axle series	Axle type	Hub cap thread	for tyre e.g.	Developed area	Hub cap with integrated Hubodometer BPW Code no.	
6.5 - 9t	H.. / R..	H.. / R..	M 115 x 2	365 / 80 R 20	3280 - 3310	05.212.23.27.0	
				385 / 65 R 22.5	3240 - 3260	05.212.23.35.0	
				10.00 R 20	3175 - 3220	05.212.23.34.0	
				11.00 R 22.5			
		H.. ECO H.. ECO-MAXX	M 125 x 2	365 / 80 R 20	3280 - 3310	05.212.24.56.0	
				385 / 65 R 22.5	3240 - 3260	05.212.24.29.0	
				425 / 65 R 22.5	3410 - 3470	05.212.24.54.0	
				10.00 R 20	3175 - 3220	05.212.24.49.0	
				11.00 R 22.5			
				315 / 70 R 22.5	3015 - 3134	05.212.24.33.0	
				275 / 70 R 22.5	2915	05.212.24.52.0	
				255 / 70 R 22.5	2830 - 2860	05.212.24.53.0	
	H.. ECO ^{Plus}	M 136 x 2.5	255 / 70 R 22.5	2830 - 2860	05.212.25.41.0		
			275 / 70 R 22.5	2915	05.212.25.42.0		
			385 / 55 R 22.5	3015 - 3134	05.212.25.44.0		
			315 / 70 R 22.5				
			10.00 R 20	3175 - 3220	05.212.25.45.0		
			11.00 R 22.5				
			385 / 65 R 22.5	3240 - 3260	05.212.25.46.0		
			12.00 R 22.5	3280 - 3310	05.212.25.47.0		
			425 / 65 R 22.5	3410 - 3470	05.212.25.48.0		
			13.00 R 22.5				
	445 / 65 R 22.5	3505	05.212.25.49.0				
	H.. ECO Plus 2	Bayonet lock	385 / 55 R 22.5	3015 - 3134	05.212.25.73.0		
			315 / 70 R 22.5				
			11.00 R 22.5	3175 - 3220	05.212.25.74.0		
			385 / 65 R 22.5	3240 - 3260	05.212.25.75.0		
	K..	K..	M 115 x 2	265 / 70 R 19.5	2620 - 2650	05.212.23.29.0	
385 / 65 R 19.5				3015 - 3134	05.212.24.33.0		
K.. ECO K.. ECO-MAXX		M 125 x 2	425 / 55 R 19.5	2960	05.212.24.46.0		
			445 / 45 R 19.5	2730 - 2790	05.212.24.50.0		
			265 / 70 R 19.5	2620 - 2650	05.212.24.34.0		
			245 / 70 R 19.5	2560	05.212.24.44.0		
			265 / 70 R 19.5	2620 - 2650	05.212.25.38.0		
			285 / 70 R 19.5	2712 - 2750	05.212.25.39.0		
KH.. ECO ^{Plus}		M 136 x 2.5	445 / 45 R 19.5	2730 - 2790	05.212.25.40.0		
			425 / 55 R 19.5	2960	05.212.25.43.0		
			KH.. ECO Plus 2	Bayonet lock	445 / 45 R 19.5	2730 - 2790	05.212.25.72.0
					215 / 75 R 17.5	2350	05.212.23.30.0
N..	N..	M 115 x 2	235 / 75 R 17.5	2425	05.212.23.31.0		
			245 / 70 R 17.5	2464 - 2520	05.212.23.36.0		
			215 / 75 R 17.5	2350	05.212.24.35.0		
	N.. ECO N.. ECO-MAXX	M 125 x 2	235 / 75 R 17.5	2464 - 2520	05.212.24.58.0		
			245 / 70 R 17.5	2425	05.212.24.36.0		
			205 / 65 R 17.5	2170	05.212.24.48.0		

Hub caps for BPW ECO axles have internal thread.

Further types upon request.

Accessory 9

Hub caps with integrated Hubodometer 9.1

Axle load	Axle series	Axle type	Hub cap thread	for tyre e.g.	Developed area	Hub cap with integrated Hubodometer BPW Code no.		
10 - 12t	H.. / R..	H.. / R..	M 125 x 2	425 / 65 R 22.5	3410 - 3470	05.212.24.32.0		
				445 / 65 R 22.5	3505	05.212.24.37.0		
				385 / 65 R 22.5	3240 - 3260	05.212.24.43.0		
				275 / 70 R 22.5	2915	05.212.24.38.0		
				10.00 R 20	3175 - 3220	05.212.24.31.0		
				11.00 R 22.5		05.212.24.39.0		
				12.00 R 22.5		3410 - 3470	05.212.24.32.0	
		13.00 R 22.5	M 135 x 2	425 / 65 R 22.5	3410 - 3470	05.212.25.11.0		
		445 / 65 R 22.5		3505	05.212.25.12.0			
		385 / 65 R 22.5		3240 - 3260	05.212.25.19.0			
		275 / 70 R 22.5		2915	05.212.25.13.0			
		10.00 R 20		3175 - 3220	05.212.25.10.0			
		11.00 R 22.5			05.212.25.10.5 Miles			
		12.00 R 22.5			3280 - 3310	05.212.25.14.0		
		13.00 R 22.5	3410 - 3470	05.212.25.11.0				
		255 / 70 R 22.5	2830 - 2860	05.212.25.24.0				
		315 / 70 R 22.5	3015 - 3134	05.212.25.25.0				
		H.. ECO H.. ECO-MAXX	H.. / R..	H.. ECO H.. ECO-MAXX	M 135 x 2	255 / 70 R 22.5	2830 - 2860	05.212.25.41.0
						275 / 70 R 22.5	2915	05.212.25.42.0
						315 / 70 R 22.5	3015 - 3134	05.212.25.44.0
						10.00 R 20	3175 - 3220	05.212.25.45.0
	11.00 R 22.5					05.212.25.46.0		
	12.00 R 22.5					3280 - 3310		05.212.25.47.0
	13.00 R 22.5					3410 - 3470	05.212.25.48.0	
	445 / 65 R 22.5			3505	05.212.25.49.0			
	H.. ECO H.. ECO-MAXX H.. ECO ^{Plus}			H.. / R..	M 136 x 2.5	255 / 70 R 22.5	2830 - 2860	05.212.25.41.0
						275 / 70 R 22.5	2915	05.212.25.42.0
						315 / 70 R 22.5	3015 - 3134	05.212.25.44.0
						10.00 R 20	3175 - 3220	05.212.25.45.0
						11.00 R 22.5		05.212.25.46.0
						12.00 R 22.5		3280 - 3310
						13.00 R 22.5	3410 - 3470	05.212.25.48.0
		445 / 65 R 22.5	3505			05.212.25.49.0		
	K..	K..	K..	M 125 x 2	285 / 70 R 19.5	2712 - 2750	05.212.24.40.0	
			KH.. ECO KH.. ECO-MAXX	M 135 x 2	285 / 70 R 19.5	2712 - 2750	05.212.25.16.0	
					265 / 70 R 19.5	2620 - 2650	05.212.25.20.0	
					245 / 70 R 19.5	2560	05.212.25.28.0	
			KH.. ECO H.. ECO-MAXX KH.. ECO ^{Plus}	M 136 x 2.5	265 / 70 R 19.5	2620 - 2650	05.212.25.38.0	
					285 / 70 R 19.5	2712 - 2750	05.212.25.39.0	
					445 / 45 R 19.5	2730 - 2790	05.212.25.40.0	
			425 / 55 R 19.5	2960	05.212.25.43.0			
			N..	N..	N..	M 125 x 2	235 / 75 R 17.5	2425
245 / 70 R 17.5	2464 - 2520	05.212.24.57.0						
9.50 R 17.5	2560	05.212.24.42.0						
8.25 R 15		05.212.25.17.0*						
N.. ECO N.. ECO-MAXX	M 135 x 2	235 / 70 R 17.5			2464 - 2520	05.212.25.51.0*		
		9.50 R 17.5			2560	05.212.25.28.0*		
		8.25 R 15				05.212.25.34.0*		
N.. ECO N.. ECO-MAXX	N..	M 136 x 2.5			205 / 65 R 17.5	2170	05.212.25.34.0*	
					215 / 75 R 17.5	2350	05.212.25.35.0*	
					245 / 70 R 17.5	2425	05.212.25.36.0*	
					235 / 75 R 17.5	2560	05.212.25.37.0*	
					9.50 R 17.5		05.212.25.37.0*	
			8.25 R 17.5					

Hub caps for BPW ECO axles have internal thread.
Further types upon request.

* Modified cap thread from 09/00.
Note thread size stamped on the cap!

9 Accessory

9.2 Hub caps with digital odometer (ECOMETER)

The BPW hub cap with its integrated digital odometer is an important instrument for checking the mileage of your trailer or semitrailer. This means you can always track the real trailer mileage, especially when the trailer is used with different tractor units.

The digital ECOMETER can be used universally for all tyre sizes.

The adjustment of the wheel size is carried out by means of the display unit (basic setting 385/65 R 22.5).

A built-in watertight mini-computer counts the wheel revolutions by means of a magnet and a reed contact.

The digital ECOMETER with the special hooked spring ring and integrated magnet is available for all BPW ECO^{Plus} axles with an M 136 x 2.5 hub cap thread, as well as ECO Plus 2 axles with a bayonet fitting.

BPW Code no.:

Hub thread M 136 x 2.5	05.212.75.06.0	KTL _{Zn}
	05.212.75.03.0	chrome ¹⁾
Bayonet lock	05.212.75.05.0	KTL _{Zn}
	incl. 'O'-Ring	
Circlip loose		
ECO ^{Plus}	05.188.04.13.0	
ECO Plus 2	05.277.10.03.0	
Replacement battery	02.0130.97.00	

¹⁾ Not corrosion-resistant acc. to DIN 50021

Further information see service and installation instruction 'Digital ECOMETER' - BPW No.: 04.001.21.24.0 and 04.001.21.25.0.



Notes